

## Van/Motorhome manual & drawing with 3 monitoring setups around a 3kVA 12V MultiPlus with Lithium SuperPack-NG batteries

(12V/230V/50Hz)

[www.victronenergy.com](http://www.victronenergy.com)

**VAN (off road) or small Motorhome drawings with: 3kVA 12V MultiPlus 230V 50Hz, 3 x 100Ah lithium SuperPack-NG batteries, SmartShunt or BMV-712 Smart, Smart Solar MPPT 100-50, Orion-XS 12/12-50 DC-DC battery charger, Digital Multi Control, VE.Bus Smart Dongle and Cerbo with GX Touch 50.**

### **What is this drawing about ?**

This is a combined drawing existing out of 3 separate drawing setups to be used for Vans (off road) or small Motorhomes for any market using 12V/230V/50Hz.

Each of the three purple dashed blocks in this combined drawing contains a slightly different setup but uses the exact same basic Victron materials as shown on the left hand side of drawing BJE-332C and that is the part without a purple dashed block.

The differences between the 3 drawings is at the control and monitoring part of each drawing.

1. Drawing BJE-332A, LH side. This is the simple version. No smart phone or tablet needed.
2. Drawing BJE-332B, Middle. This is Smart version-1. A smart phone or tablet is needed.
3. Drawing BJE-332C, RH side. This is Smart version-2. No smart phone or tablet needed, but this system can also be monitored with a smart phone or tablet and if needed from anywhere in the world with an internet connection through the Victron VRM App or website.

### **The basic Victron system works as follows:**

Each basic system has been built around a 3kVA MultiPlus and the Li batteries in use are Victron 12.8V-100Ah Lithium SuperPack-NG. These are so called Drop In Li batteries and 3 of them adds up to 300Ah total Li battery capacity. Protection of the Li batteries from a charge and discharge point of view is taken care of by each batteries own built in BMS system.

To make sure you will not run out of power that easily, there are multiple charge possibilities available for this setup:

1. AC Campsite Power that will enable the 3kVA MultiPlus Inverter/Charger to charge with 120 Amps towards the Li batteries.
2. DC Solar Power that will enable the Smart Solar MPPT 100|50 to charge towards the Li batteries. The total Charge capacity depends on the size of the installed Solar array.
3. DC Engine charging power that will enable the Orion XS 12/12-50 DC-DC battery charger to charge with 50 Amps towards the Li batteries when the Engine runs.

Charge combinations of the above mentioned devices also are possible.

DC users like lights, pumps and so on, can be connected behind a DC switch panel and a small negative Busbar.

AC Power will be available from the 3kVA MultiPlus Inverter/Charger the moment it has been switched on. This means that without any AC power on the input, the MultiPlus will give you 3kVA of inverter power on AC OUT-1. The moment AC Power is available on input AC IN-1 of the MultiPlus, AC Power will be used to charge the batteries and also is available for loads connected to AC OUT-1. The second AC output AC OUT-2 is live only when AC power is available on the input of the MultiPlus.

**The simple version, No Smart Phone Needed:** has a BMV-712 Smart Battery Monitor to watch over your batteries and a Digital Multi Control (DMC). With the BMV one can check that the batteries are not being depleted too much and to keep a watchful eye over the State of Charge (SoC), Voltage, Amps, hours to go and so on. With the easily settable Digital Multi Control one can adjust the available AC campsite power to the maximum AC current the MultiPlus will use. One can also switch the MultiPlus remotely On/Off or to Charger Only. Both devices will help you to control your "on board" AC and DC power availability. More info about the system and its individual Victron parts used in this installation are explained in more details down below.

**Smart Version-1, Smart Phone Needed:** has a SmartShunt to watch over your batteries and a VE.Bus Smart Dongle to control your MultiPlus. With the SmartShunt one can check that the

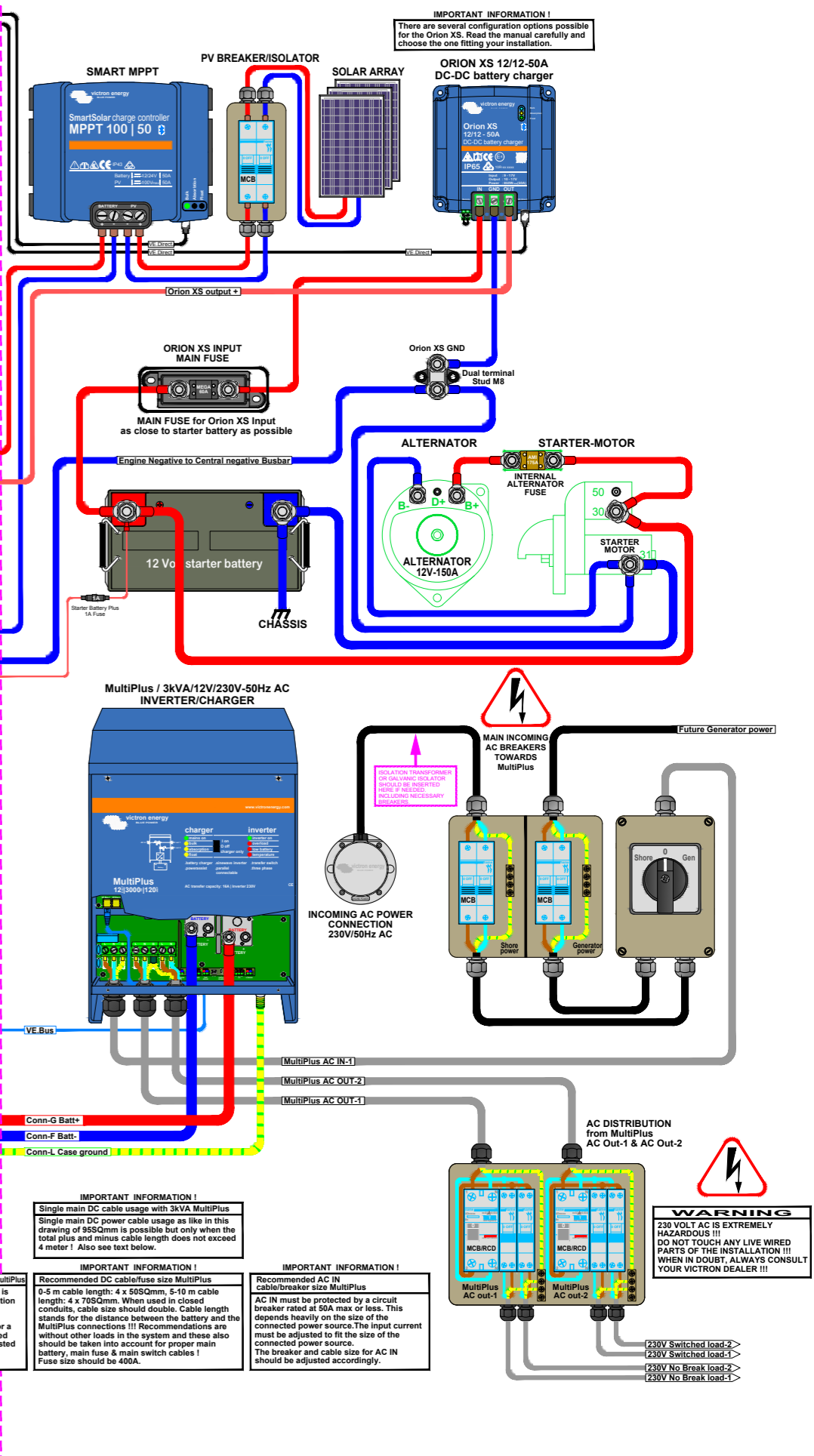
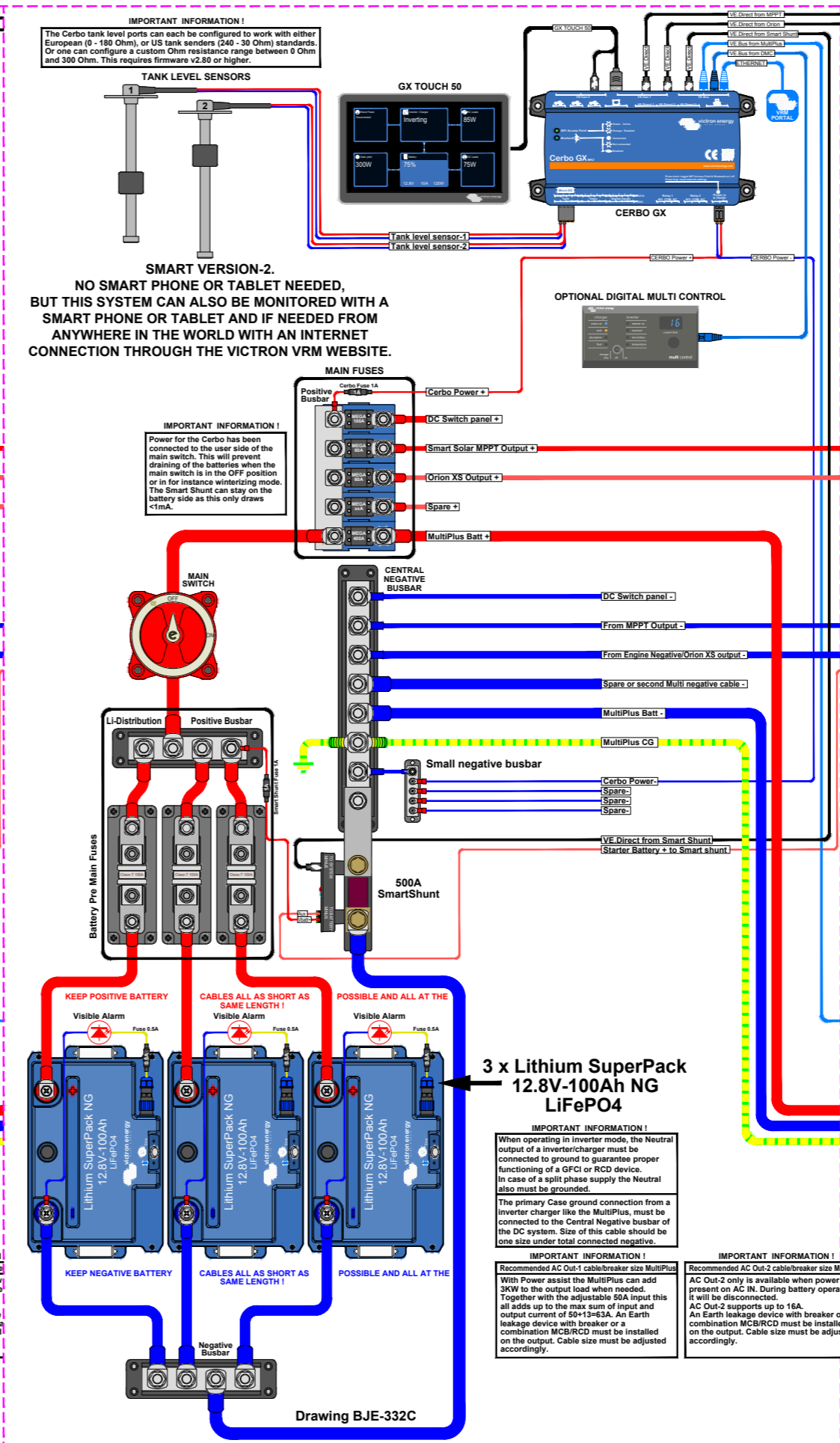
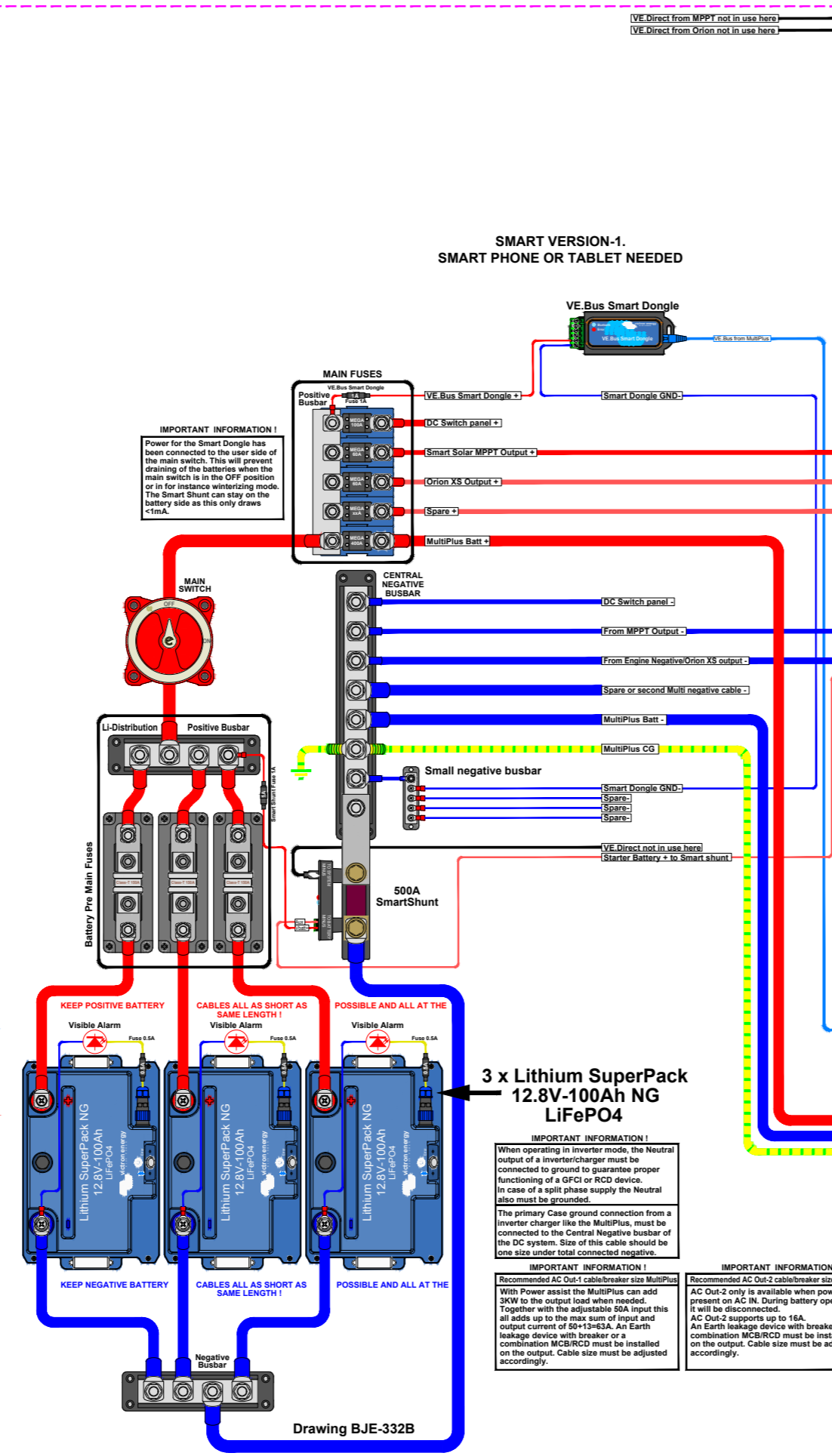
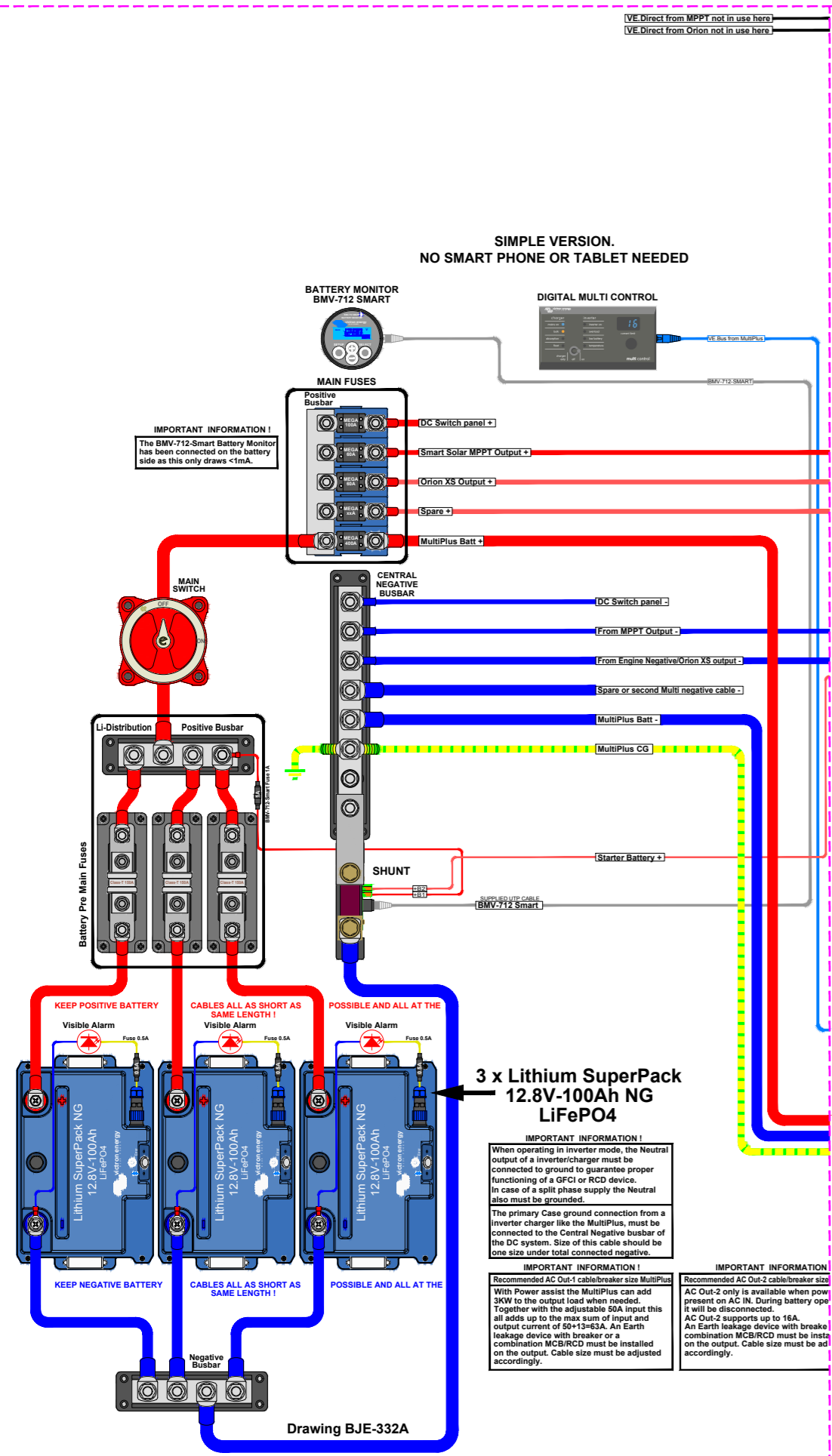

batteries are not being depleted too much and to keep a watchful eye over the State of Charge (SoC), Voltage, Amps, hours to go and so on.

With the VE.Bus Smart Dongle one can keep a watchful eye over the MultiPlus and for instance adjust the available AC campsite power to the maximum AC current the MultiPlus will use. One can also switch the MultiPlus remotely On/Off or to Charger Only. The Dongle also measures the battery temperature, Battery Charge/discharge, Voltage and Amps, AC Input and Output Voltage, Amps, Power and Frequency. Both devices will help you to control your "on board" AC and DC power availability. More info about the system and its individual Victron parts used in this installation are explained in more details down below.

**Smart Version-2, No Smart Phone needed, but a Smart Phone can be used as well:**

has a SmartShunt to watch over your batteries, a Cerbo with a GX Touch 50 display and an optional Digital Multi Control. With the SmartShunt connected to the Cerbo one can check that the batteries are not being depleted too much and to keep a watchful eye over the State of Charge (SoC), Voltage, Amps, hours to go and so on. The Cerbo can also be used to keep a watchful eye over the MultiPlus and for instance adjust the available AC campsite power to the maximum AC current the MultiPlus will use. One can also switch the MultiPlus remotely On/Off or to Charger Only. The Cerbo also displays Battery Voltage and Amps, AC Input and Output Voltage, Amps, Power and Frequency and so on. More info about the system and its individual Victron parts used in this installation are explained in more details down below.

**This is how the system has been setup:**

**Around the Victron 12.8V-100Ah Lithium SuperPack-NG batteries (used in all drawings).**

There are three Victron 12.8V-100Ah Lithium SuperPack-NG batteries in each drawing. Following the drawings from the bottom-left, all positive battery terminals are connected to an individual Class-T fuse-holder with a 150A fuse. The top side of the Class-T fuse holders are connected together with use of a Victron Busbar. On the same Busbar is a small fuse holder connected for a BMV-712 Smart battery monitor with its Shunt or for a SmartShunt depending on what monitoring equipment is being used. A fuse of 1A will keep the power on 24-7. Between the three Class-T fuse holders is a cable connection that runs to the systems Main Switch and from the Main Switch a cable connection has been made to a Victron positive Busbar that connects to 5x Victron modular Mega fuse holders.

All three negative battery terminals are directly connected to a Victron Busbar. From this Busbar a cable connection runs to the battery connection of a Shunt. The Shunt model depends on what monitoring equipment is being used. From the user side of the Shunt a connection has to be made to the Central Negative Busbar. One can use a piece of tinned Copper Busbar for this or a cable connection.

Possibly also connected here is a small negative Busbar that could be needed for a VE.Bus Smart Dongle negative connection or for a Cerbo negative connection depending on what monitoring equipment is being used and some other small users for future use.

**BMV-712 Smart Battery Monitor with 500A Shunt used in Simple Version only:**

The BMV-712 used in the simple version drawing has two positive connection terminals, one for its own Power and measurements named B1 and one called B2.

The B1 connection comes from the Positive Busbar for the Li batteries and a 1A fuse also as explained above. The B2 connection is being used to measure the Battery Voltage of the Van's Starter battery with a In-Line fuse of 1A to be connected close to the positive starter battery terminal and connected to the B2 connection of the Shunt of the BMV-712. The negatives of the starter battery and the service batteries have to be connected together to make this work (this connection is available in all 3 versions). The Smart Shunt VE.Direct connection on the BMV-712 will not be used here.

**SmartShunt 500A used in Smart Version-1 and Smart Version-2:**

The Smart Shunt 500A used in drawing Smart Version-1 and -2 has two positive connection terminals, one for its own Power and measurements named Vbatt+ and one called Aux.

The Vbatt+ connection comes from the Positive Busbar for the Li batteries and a 1A fuse also as explained above. The Aux connection is being used to measure the Battery Voltage of the Van's Starter battery with the extra supplied In-Line fuse of 1A to be connected close to the positive

starter battery terminal and connected to the Aux connection of the Smart Shunt. The negatives of the starter battery and the service batteries have to be connected together to make this work (this connection is available in all 3 versions). The Smart Shunt VE.Direct connection will not be used in Smart Version-1, but will be in Smart Version-2. A VE.Direct cable has to be connected between the Cerbo and SmartShunt and by doing this all battery information will be available on the GX Touch-50 screen.

### **5 x Main fuses with directly connected Positive Busbar and Central Negative Busbar. (used in all drawings):**

The Victron positive Busbar with 5x Victron modular Mega fuse holders is easy to setup.

The 5x modular Mega fuse holders connect to each other with a Dovetail feature and the Positive Busbar fits over 1 side of the Mega fuse holder connections.

This block of 5 Mega main fuse holders is the DC distribution point of the installation.

It is very important NOT to install any main fuses until one is finished making all the connections and double check to make sure all connections are made as should be.

Always first start with connecting the negative cable for each user to the Central Negative Busbar before connecting the positive to its dedicated Main Fuse position.

Read the supplied manuals for additional information.

1. The first fuse position holds a 100A fuse for the DC switch panel together with its Central Negative Busbar connection. The fuse size is an example only and should be adjusted to what is needed from a load size point of view.
2. The second fuse position holds a 60A fuse together with its Central Negative Busbar connection for the output of a Smart Solar charge controller MPPT 100|50.
3. The third fuse position holds a 60A fuse together with a combined negative for: Engine negative, Orion-XS and Central Negative Busbar.
4. The fourth fuse position holds a spare fuse together with a spare negative or a second MultiPlus negative cable.
5. The fifth fuse position holds a 400A fuse together with its Central Negative Busbar connection for the biggest device in this installation, a 3kVA MultiPlus inverter/charger. Keep the distance between the Main fuses/Central Negative Busbar and the MultiPlus as short as possible. If that cannot be achieved, consider doubling up the positive and negative DC cables to power up the MultiPlus more efficiently. Read the MultiPlus manual carefully to proceed further.

The PE/Earth/CG connection will be dealt with later together with the MultiPlus.

### **Digital Multi Control used in the Simple version and Smart version-2:**

The Digital Multi Control (DMC) is used in the Simple Version and optional in Smart Version-2.

With a DMC one can remotely view the MultiPlus status and adjust the AC input current of the MultiPlus in a direct and easy way, and you can switch your MultiPlus remotely On or Off, or to Charger Only.

### **VE.Bus Smart Dongle used in Smart version-1 only:**

As more or less explained above the VE.Bus Smart Dongle has the following features and functionalities: The dongle can remotely monitor and control the 3kVA MultiPlus inverter/charger via Bluetooth with use of the VictronConnect app. The inverter/charger can be switched to On, Off or charger-only, the AC input current limit can be adjusted and the AC and DC parameters, device status, warnings or alarms can be monitored. The positive power for the Dongle comes from a 1A fuse connected to the Victron positive Busbar with 5x Victron modular Mega fuse holders. The negative power for the Dongle comes from the small negative Busbar.

### **Cerbo GX with GX Touch 50 Display used in Smart version-2 only:**

Monitoring of your installation can be done either with the Cerbo's GX Touch display in front of you or from anywhere in the world using an internet connection as shown in the drawing with a connection to the Victron VRM portal either using the Victron connect app or website.

The Cerbo also provides Remote Firmware updates and allows settings to be changed Remotely.

Whatever you connect to a Cerbo can be made visible on the GX Touch 50 display or with:

Remote Console, VRM Dashboard, Advanced VRM Widgets, VRM App Widgets, and

VE.Can/NMEA 2000. This all has been clearly explained in the latest Cerbo manual.

The positive power for the Cerbo comes from a 1A fuse connected to the Victron positive Busbar with 5 x Victron modular Mega fuse holders. The negative power for the Cerbo comes from the small negative Busbar. The GX Touch 50 Display HDMI connector with attached USB power cable obviously has to go into the HDMI port of the Cerbo and the USB cable directly next to it. The VE.Bus cable coming from the 3kVA MultiPlus inverter/charger and the VE.Bus cable coming from optional Digital Multi Control both go into a VE.Bus port of the Cerbo. The Ethernet cable and its connector, to connect to the VRM Portal (if available), will go into the Network port of the Cerbo. The VE.Direct cable from the Smart Shunt goes into a VE.Direct port of the Cerbo and the same for the VE.Direct cable from the Smart Solar MPPT 100|50 and from the Orion XS. Also made visible and connected to the Cerbo here is Tank measurement. Two resistive hard wired tank senders are connected to Tank Level port 1 and 2. The tank level ports can each be configured to work with either European (0 - 180 Ohm), or US tank senders (240 - 30 Ohm) standards, or one can configure a custom Ohm resistance range between 0 Ohm and 300 Ohm (requires firmware v2.80 or higher).

These are all the connection you have to make for the Cerbo. There is plenty more you can connect and do with a Cerbo and that all is very well explained in its manual.

**SmartSolar charge controller MPPT 100|50 (used in all drawings):**

Next to the Cerbo you will find a Smart Solar charge Controller MPPT 100|50.

Also visible here is a PV breaker/Isolator. The Solar array as shown in the drawing is just to visualize some solar panels and how things need to be connected.

It might be a good idea that you use the free MPPT sizing calculator available from the Victron website. This is a great and accurate tool to size what you need on Solar panel power and charge controllers for your Van or Motorhome. On the Victron Website search for MPPT calculator. DC power from the solar array first passes through the PV breaker/Isolator and then connects to the MPPT PV input connections. The positive DC Output connection of the MPPT connects to the second fuse position of the 5x modular Mega fuse holders as explained previously. The second fuse position holds a 60A fuse together with its Central Negative Busbar connection for the MPPT output. The VE.Direct cable and connector from the MPPT has been connected to a Cerbo VE.Direct Port in Smart version-2.

**Orion XS 12/12-50A DC-DC battery charger (used in all drawings):**

Next to the PV Breaker/Isolator and Solar Array you will find a Orion XS 12/12-50A DC-DC battery charger. The total charge current of the Orion XS is 50A and future models will go higher like 70A. The Orion XS is a Non isolated device. The L & H connections are bridged and this means that the Orion XS needs to be configured for auto start stop mode and for either a normal or a Smart Alternator and for charging Li mode. Read the manual carefully and make the correct settings accordingly. The Power input for the Orion XS comes from the starter battery positive through an individual Orion XS main fuse of 60 Amp and from the starter motor negative connection-31 (Black Dual Victron terminal stud).

The positive DC Output connection of the Orion XS connects to the third fuse position of the 5x modular Mega fuse holders as explained previously. The third fuse position holds a 60A fuse together with its combined Central Negative Busbar connection. The Central Negative Busbar is connected with the negative output of the Orion XS, the engine negative and the Starter Battery negative by means of a Black Dual Victron terminal stud. The VE.Direct cable and connector from the Orion XS has been connected to a Cerbo VE.Direct Port in Smart version-2.

**Engine System (used in all drawings):**

The starter circuit of the engine with Starter Battery and Chassis ground connections, Alternator with main fuse and Starter Motor visible in this drawing should be seen as an example to show you how to connect your Victron products.

**MultiPlus Inverter/Charger 3kVA/12V 230V/50Hz AC (used in all drawings):**

Below the starter circuit you will find the MultiPlus Inverter/Charger.

The MultiPlus should be mounted in such a way that it can cool itself down properly and the space where it is in should be dry and well ventilated. Free space around the device should be at least 10cm or 4". Don't box the device in as this will certainly have a bad effect on its functioning and service life.

Most connections to and from the MultiPlus already have been discussed, but it might be a good idea to have them all together here again:

The DC power to and from the MultiPlus connects to the fifth fuse position holding a 400A fuse together with its Central Negative Busbar connection.

Incoming AC power into the Van or Motorhome comes through a Victron Camp site or Shore Power connection of normally 16A. From there it passes through an incoming AC breaker box towards a possible change over switch for: Shore power-0-Generator power.

If there is a generator installed with a breaker box, the breaker for Shore power and the breaker for Generator power will connect to its individual change over switch connections before connecting to the MultiPlus AC IN-1 connections.

If no change over switch and generator are in use here, the breaker for shore power connects directly to the MultiPlus AC IN-1 connections.

AC OUT-1 of the MultiPlus is connected to an AC breaker box with a MCB/RCD device and some user breakers. The amount of user breakers depends on the setup of the Van or Motorhome. These are NO Break AC outputs and as the name suggests are constantly powered through the MultiPlus Inverter.

AC OUT-2 of the MultiPlus is also connected to an AC breaker box with a MCB/RCD device and some user breakers. The amount of user breakers also depends on the setup of the Van or Motorhome.

These are switched AC outputs and as the name here suggests are switched off when there is no incoming AC power available. AC OUT-2 is live only when AC power is available on the AC input of the MultiPlus with a 2 minute connect delay.

When any other AC power connections are made between the shore power connection and the MultiPlus or between the Generator power and the MultiPlus, extra MCB/RCD devices with breakers need to be installed for your own safety.

The MultiPlus has two VE.Bus connections:

In the Simple version one is used for the Digital Multi Control and the other one is Spare.

In Smart version-1 one is used for the VE.Bus Smart Dongle and the other one is Spare.

In Smart version-2 one is used for the Cerbo and the other one is Spare.

The MultiPlus has a Case Ground connection-L that should be connected to the Central negative Busbar as shown in this drawing. The Case Ground cable should be one size smaller compared to its total connected DC negative. (Check the DC Case Grounding rules from ABYC as there might be a revision underway).

All shown connections in this drawing, are made according to CE/ABYC regulations.

This is a NON Isolated DC System setup. When in doubt about how to continue further with these connections, consult your Victron dealer.

Read the MultiPlus manual carefully to proceed further.

### **Software settings for all shown Victron devices in this drawing:**

- When setting up a new system, it will be good practice to update all Victron devices to the latest available Software/Firmware.
- The Victron 12.8V-100Ah Lithium SuperPack-NG batteries can be set, monitored and updated with use of the VictronConnect App.
- The Victron Smart Shunt 500A can be set, monitored and updated with use of the VictronConnect App. Don't forget to set the Battery capacity.
- The Victron Battery Monitor BMV-712 Smart can be set, monitored through its own device settings or it can be set, monitored and updated with use of the VictronConnect App. Don't forget to set the Battery capacity.
- The Victron VE.Bus Smart Dongle can be set, monitored and updated with use of the VictronConnect App.
- The Victron Digital Multi Control panel or DMC comes ready out of the box and does not need any updates.

- The Victron Smart Solar charge controller MPPT 100|50 can be set, monitored and updated with use of the VictronConnect App. Must be programmed for Li-Ion mode and 12V.
- The Orion XS 12/12-50A DC-DC battery charger can be set, monitored and updated with use of the VictronConnect App. Must be programmed for Li-Ion mode. Adjust settings for start and stop charging according to installed alternator and if it is a normal or Smart alternator.
- The Victron Cerbo GX Device can be updated to the latest Firmware in two different ways:
  - 1 - Update it via the internet, either manually or let it check for new updates every day.
  - 2 - Update it from a microSD-card or USB-stick. Check the Cerbo manual for this.
- The Victron MultiPlus can be set, monitored and updated with use of the MK3-USB interface and VEConfigure software (Windows only) or use the VictronConnect App (Multi Platform). Limitations of VictronConnect are that one cannot add assistants, use Virtual Switch and/or change the Grid Code.

### **Wiring Calculations:**

There are no wire sizes visible in this drawing and there is a good reason why this is not available in any drawing on the Victron website. We at Victron do not know what the physical size of your project is and it therefore will be impossible to give you specific wire sizes that will fit your setup. But there is a very handy tool available from Victron called Victron Toolkit for Android and iPhone users. In this app you will find Cable Calc that will help you size any cable for AC and DC. This will help you find all the right cable sizes for your project.

### **Wiring Unlimited:**

This is a book freely available for downloading from the Victron Website.

This book is all about electrical wiring for systems containing batteries, inverters, charger, inverter/chargers and so on. With this book Victron aims to explain wiring basics of electrical systems. This book helps to explain the importance of 'getting it right' and the issues that might happen when a system has inferior wiring. It also assists electrical installers or users to troubleshoot issues that have arisen from bad wiring. This book will certainly help to get it right and to make sure proper conclusions can be drawn for the electrical systems its readers are involved with.

### **Using the Victron-Remote-Monitoring / VRM app or website:**

Monitoring of your installation can be done either with the Cerbo's GX Touch display in front of you or from anywhere in the world using an internet connection as shown in the drawing with a connection to the Victron VRM portal either using the Victron connect app or website.

Just login to your VRM account or setup a new one and tap on your account to view your installation. You can for instance set alarm status information for the state of charge or SoC and this will automatically warn you when a certain level has been reached. This is extremely useful for long time parking or winterizing mode and..... it is free of charge !

For more info read the latest available VRM manual.

The VRM app is available for Android and iPhone users.

### **Parking for a longer period of time:**

Make sure to switch the MultiPlus to charger only. This prevents the inverter from draining the batteries when no AC input power is available. When parked outside, the solar panels will maintain the batteries, but only when parked away from shade.

### **Winterizing:**

Before putting the Van or motorhome in hibernation for winterizing, make sure to fully charge the batteries first. Then switch off the MultiPlus and the main switch. The BMV-712 or Smart Shunt is on 24-7. Check at regular intervals if the batteries are not losing too much capacity and make sure to prevent freezing at all times. A regular interval is 4-6 weeks.

Installing a small Victron maintenance charger for wintertime is a very good investment.

With for instance a Victron Blue Smart IP65 Charger 230V/12V/10A, you can switch off the MultiPlus and only use the maintenance charger and monitor your system with use of the VRM app or website. You do need an Internet connection to make this work and Victron also has a solution for this with the GX LTE 4G cellular modem.

Check it out on the Victron website.

**In this drawing you will find the following Victron equipment with some additional material:**

Victron Part description	Part No.	Amount	Remark
Battery Monitor BMV-712 Smart	BAM030712000 (R)	1	
Blue Sea E-Series Battery Switch on/off 350A continuous 600A 5min intermitting	9003E	1	
Blue Sea Class-T Pre-Main fuse holders for the SuperPack-NG Li batteries	5007100	3	
Blue Sea Class-T 150A Main fuse	5114	3	
Blue Sea Mini Busbar - 5 Gang with Cover	2314	1	
Breaker box PV with DC breaker isolator for solar Array		1	Order from your Victron dealer
Breaker box MultiPlus AC OUT-1 & AC OUT-2	.....	1	Order from your Victron dealer
Breaker box MultiPlus AC Shore power Input and AC Generator power Input	.....	1	Order from your Victron dealer
Busbar 600A 4P + cover	VBB160040010	2	
Busbar 600A 8P + cover	VBB160080010	1	
Busbar to connect 5 Modular fuse holders for Mega-fuse CIP100200100 (500 A)	CIP100400060	1	
Change Over Switch between AC Shore and AC Generator power with Off position, routing AC power to MultiPlus AC IN-1 (if needed)	.....	1	Order from your Victron dealer
Cerbo GX MK2	BPP900450100	1	
Digital Multi Control 200/200A GX	DMC000200010R	1	
Dual Terminal Stud M8-linked set (1 red/1 black)	VBB413020010	1	Set of 2
Fuse holder 2AG or 5x20mm by Little Fuse including fuses if needed	150 series	6	Order on line or from your Victron dealer
Fuse holder for MEGA-fuse (Orion XS input)	CIP000100001	2	
GX Touch 50 Display	BAT512110740	1	
12.8V-100Ah Lithium SuperPack-NG battery	BAT512110710	3	
MEGA-fuse 60A/32V (package of 5 pcs)	CIP136060010	1	
MEGA-fuse 100A/32V (package of 5 pcs)	CIP136100010	1	
MEGA-fuse 400A/32V (package of 5 pcs)	CIP136400010	1	
Modular fuse holder for Mega-fuse (1 till 5)	CIP100200100	5	
MultiPlus 12/3000/120-16 230V	PMP122300001	1	
Orion XS 12/12-50A DC-DC battery charger	ORI121217050	1	

<b>Victron Part description</b>	<b>Part No.</b>	<b>Amount</b>	<b>Remark</b>
Power Inlet 16A stainless steel with cover	SHP 301602000	1	
Power Cord 15m 16A for shore power inlet	SHP 302501500	1	
SmartShunt 500A/50mV	SHU050150050	1	
SmartSolar MPPT 100/50	SCC110050210	1	
VE.Bus cables: from Multiplus to: Cerbo or VE.Bus Smart Dongle or Digital Multi Control and from Cerbo to DMC	.....	0	Cable lengths not known
VE.Bus Smart dongle	ASS030537010	1	
VE.Direct cables: from MPPT to Cerbo, from Smart Shunt to Cerbo & from Orion XS to Cerbo	.....	3	Cable lengths not known

Victron Energy B.V. | De Paal 35 | 1351 JG Almere | The Netherlands  
 General phone: +31 (0)36 535 97 00  
 E-mail: [sales@victronenergy.com](mailto:sales@victronenergy.com) | [www.victronenergy.com](http://www.victronenergy.com)