

MultiPlus-II inverter/charger Australia

48V - 3k, 5k, 8k, 10k, 15k

Table of Contents

1. Safety Instructions	1
2. Description	3
2.1. Features	3
2.2. Battery charger	4
2.2.1. Lead-acid batteries	4
2.2.2. More on batteries and battery charging	4
2.2.3. Victron Lithium Batteries	5
2.2.4. Other lithium batteries	5
3. Installation	6
3.1. Location	6
3.2. Mounting	7
3.3. DC connection	8
3.4. AC connection	9
3.5. Optional connections	10
3.5.1. Remote control	10
3.5.2. Programmable relay	10
3.5.3. Programmable analogue/digital input/output ports	10
3.5.4. Voltage sense	10
3.5.5. Temperature sensor	11
3.5.6. Parallel connection	11
3.5.7. Three-phase operation	11
4. Configuration	12
4.1. Default settings	12
4.2. Configuring	12
4.2.1. Set the grid code	13
4.2.2. ESS configuration	13
4.2.3. VictronConnect	13
4.2.4. VEConfigure	13
4.2.5. VE.Bus Quick Configure Setup	13
4.2.6. VE.Bus System Configurator	13
4.3. Explanation of settings	13
4.4. Firmware	16
5. Operation	17
5.1. On/off/charger-only switch	17
5.2. Remote control	17
5.3. LED Indications	17
5.4. Equalisation and forced absorption	20
5.4.1. Activating equalisation or forced absorption	20
5.4.2. Equalisation	21
5.4.3. Forced absorption	21
5.5. Shut down procedure	21
6. Maintenance	22
7. Troubleshooting	23
7.1. General error indications	23
7.2. Special LED indications	24
7.3. VE.Bus LED indications	25
7.3.1. VE.Bus OK codes	25
7.3.2. VE.Bus error codes	25
8. Support	28
9. Warranty	29
9.1. Victron Energy limited warranty policy	29
9.2. Australian warranty statement	30

10. Technical specifications	31
10.1. Technical specifications	31
10.2. Technical specifications	33
11. Appendix	35
11.1. Connection overview	35
11.2. Grid connection	37
11.3. Generator connection	38
11.4. Stand alone wiring diagram	39
11.5. Block diagram	40
11.6. Parallel connection	40
11.7. Three phase connection	41
11.8. Charge algorithm	41
11.9. Temperature compensation	42
11.10. Dimensions	44

1. Safety Instructions

In general

Please read the documentation supplied with this product first, so that you are familiar with the safety signs and directions before using the product.

This product is designed and tested in accordance with international standards. The equipment should be used for the designated application only.



Warning – These servicing instructions are for use by qualified personnel only. To reduce the risk of electric shock, do not perform any servicing other than that specified in the operating instructions unless you are qualified to do so

The product is used in combination with a permanent energy source (battery). Even if the equipment is switched off, a dangerous electrical voltage can occur at the input and/or output terminals. Always switch the AC power off and disconnect the battery before performing maintenance.

The product contains no internal user-serviceable parts. Do not remove the front panel and do not put the product into operation unless all panels are fitted. All maintenance should be performed by qualified personnel. Internal fuses are not user replaceable. A unit with suspected blown fuses should be taken to an authorized service center for evaluation.

Never use the product at sites where gas or dust explosions could occur. Refer to the specifications provided by the manufacturer of the battery to ensure that the battery is suitable for use with this product. The battery manufacturer's safety instructions should always be observed.

This appliance is not intended for use by persons (including children) with reduced physical, sensory or mental capabilities, or lack of experience and knowledge unless they have been given supervision or instruction concerning the use of the appliance by a person responsible for their safety. Children should be supervised to ensure that they do not play with the appliance.



Do not lift heavy objects unassisted.



Installation

Read the installation instructions before commencing installation activities. For electrical work, follow the local national wiring standard, regulations, and installation instructions.



All Australian installations shall comply with the requirements of AS/NZS 3000 and AS/NZS 4509.1.

This product is a safety class I device (supplied with a ground terminal for safety purposes). **Its AC input and/or output terminals must be provided with uninterruptible grounding for safety purposes. An additional grounding point is located on the outside of the product. The ground conductor should be at least 4mm².** If it can be assumed that the grounding protection is damaged, the product should be taken out of operation and prevented from accidentally being put into operation again; contact qualified maintenance personnel.

Ensure that the connection cables are provided with fuses and circuit breakers. Never replace a protective device by a component of a different type. Refer to the manual for the correct part.

Do not invert neutral and phase when connecting the AC.

Check before switching the device on whether the available voltage source conforms to the configuration settings of the product as described in the manual.

Ensure that the equipment is used under the correct operating conditions. Never operate it in a wet or dusty environment. Ensure that there is always sufficient free space around the product for ventilation, and those ventilation openings are not blocked. Install the product in a heatproof environment. Ensure, therefore, that there are no chemicals, plastic parts, curtains or other textiles, etc. in the immediate vicinity of the equipment.

This inverter is provided with an internal isolation transformer providing reinforced insulation

Transport and storage



On storage or transport of the product, ensure that the AC supply and battery leads are disconnected.

No liability can be accepted for damage in transit if the equipment is not transported in its original packaging.

Store the product in a dry environment; the storage temperature should range from -20°C to 60°C .

Refer to the battery manufacturer's manual for information on transport, storage, charging, recharging, and disposal of the battery.

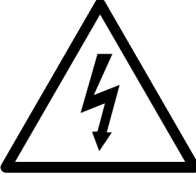
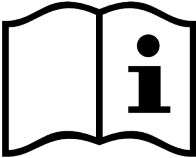
Symbols on the enclosure

Symbol	Description
	Caution, hot surface
	Caution, risk of electric shock
	Refer to the operating instructions
IP21	IP21 Protected from touch by fingers and objects greater than 12 millimetres. Protected from condensation.
	European conformity
	Regulatory compliance mark for Australia & New Zealand

2. Description

The MultiPlus-II is an extremely powerful sine inverter, battery charger and transfer switch in a compact casing.

It is suitable for energy storage and backup systems, both on and off-grid, as well as marine, automotive, and stationary land-based applications.

This manual applies to:

- MultiPlus-II 48/3000/35-32 230V
- MultiPlus-II 48/5000/70-50 230V
- MultiPlus-II 48/8000/110-100 230V
- MultiPlus-II 48/10000/140-100 230V
- MultiPlus-II 48/15000/200-100 230V

2.1. Features

Automatic and uninterruptible switching

If the AC input is switched off or fails, the MultiPlus-II will switch over to inverter operation and take over the supply of the connected devices. This is done so quickly that the operation of computers and other electronic devices is not disturbed (Uninterruptible Power Supply or UPS functionality). This makes the MultiPlus-II highly suitable as an emergency power system in backup, off-grid, industrial and telecommunication applications.

Energy Storage system

This unit can be used in an energy storage system (ESS); for further information, refer to the [ESS design and installation manual](#).

Two AC outputs

Besides the usual uninterruptible output (AC-out-1), an auxiliary output (AC-out-2) is available that disconnects its load in the event of battery operation. Example: an electric boiler that is allowed to operate only if the generator is running. There are several applications for AC-out-2.

Please enter "AC-out-2" in the search box on our website and find the latest information about other applications.

Three phase capability

Three units can be configured for three-phase output. Up to 6 sets of three units can be parallel connected.

PowerControl – maximum use of limited AC power

The MultiPlus-II can supply a huge charging current. This implies heavy loading of the AC supply. Therefore, a maximum current can be set. The MultiPlus-II then takes other power users into account and only uses "surplus" current for charging purposes.

PowerAssist – Extended use of generator or shore current: the MultiPlus-II "co-supply" feature

This feature takes the principle of PowerControl to a further dimension, allowing the MultiPlus-II to supplement the capacity of the alternative AC source. Where peak power is often required only for a limited period, the MultiPlus-II will make sure that insufficient AC power is immediately compensated for by power from the battery. When the load reduces, the spare power is used to recharge the battery.

Programmable relay

The MultiPlus-II is equipped with a programmable relay. The relay can be programmed for different applications, for example, as a starter relay for a generator.

External current transformer (optional)

External current transformer option to implement PowerControl and PowerAssist with external current sensing.

Frequency shift

When AC solar inverters are connected to the output of a MultiPlus-II, excess solar energy is used to recharge the batteries. Once the absorption voltage is reached, the MultiPlus-II will slightly increase the AC frequency to reduce the output of the solar inverter.

Built-in Battery Monitor

The ideal solution when the MultiPlus-II is part of a hybrid system (diesel generator, inverter/chargers, storage battery, and alternative energy). The built-in battery monitor can be set to start and stop the generator:

- Start at a preset % discharge level, and/or

- start (with a preset delay) at a preset battery voltage, and/or
- start (with a preset delay) at a preset load level.
- Stop at a preset battery voltage, or
- stop (with a preset delay) after the bulk charge phase has been completed, and/or
- stop (with a preset delay) at a preset load level.

Programmable analogue/digital input/output ports (Aux in 1 and Aux in 2, see appendix)

The MultiPlus-II is equipped with 2 analogue/digital input/output ports. These ports can be used for several purposes. One application is communication with the BMS of a lithium-ion battery.

Programmable settings

All settings can be changed with a computer and free of-charge software, downloadable from our website www.victronenergy.com.

2.2. Battery charger

2.2.1. Lead-acid batteries

Adaptive 4-stage charge algorithm: bulk – absorption – float – storage

The microprocessor-driven adaptive battery management system can be adjusted for various types of batteries. The adaptive function automatically adapts the charging process to battery use.

The right amount of charge: variable absorption time

In the event of slight battery discharge, absorption is kept short to prevent overcharging and excessive gas formation. After deep discharging, the absorption time is automatically extended in order to fully charge the battery.

Preventing damage due to excessive gassing: the BatterySafe mode

If, in order to quickly charge a battery, a high charge current in combination with a high absorption voltage has been chosen, damage due to excessive gassing will be prevented by automatically limiting the rate of voltage increase once the gassing voltage has been reached.

Less maintenance and aging when the battery is not in use: the Storage mode

The Storage mode kicks in whenever the battery has not been subjected to discharge during 24 hours. In the Storage mode float voltage is reduced to 2.2V/cell (13.2V for 12V battery) to minimise gassing and corrosion of the positive plates. Once a week the voltage is raised back to the absorption level to 'equalize' the battery. This feature prevents stratification of the electrolyte and sulphation, a major cause of early battery failure.

Battery voltage sense: the correct charge voltage

Voltage loss due to cable resistance can be compensated by using the voltage sense facility to measure voltage directly on the DC bus or on the battery terminals.

Battery voltage and temperature compensation

The temperature sensor serves to reduce charging voltage when battery temperature rises. This is particularly important for maintenance-free batteries, which could otherwise dry out by overcharging.



The temperature sensor is not supplied with 48V models.

It can be ordered separately. Order number: ASS000001000

Two DC outputs for charging two batteries

The main DC terminal can supply the full output current. The second output, intended for charging a starter battery, is limited to 4A and has a slightly lower output voltage (12V and 24V models only).

2.2.2. More on batteries and battery charging

Our book "[Energy Unlimited](#)" offers further information on batteries and battery charging and is available free of charge on our website. It can be downloaded from: <https://www.victronenergy.com/upload/documents/Book-Energy-Unlimited-EN.pdf>, or a hard copy can be ordered from: <https://www.victronenergy.com/orderbook>

For more information on adaptive charging, please refer to the technical paper: [Adaptive charging, how it works](#).

2.2.3. Victron Lithium Batteries

If Victron Lithium Smart batteries are used, use the VE.Bus BMS V2 or the Lynx Smart BMS.

2.2.4. Other lithium batteries

If other lithium batteries are used, follow this link for a list of compatible battery types and instructions on installing and configuring them: https://www.victronenergy.com/live/battery_compatibility:start.

3. Installation



This product may only be installed by a qualified electrician.

3.1. Location

The product is rated IP21. Therefore, it must be installed indoors, in a dry and well-ventilated area, as close as possible to the batteries. Ensure there is a clear space of at least 10 cm around the appliance for cooling. It can be installed in a conditioned or unconditioned environment; however, if installed in a hot environment, conditioning is recommended to avoid inverter power deration due to high ambient temperatures.



Excessively high ambient temperature will result in the following:

- Reduced service life.
- Reduced charging current.
- Reduced peak capacity or shutdown of the inverter.

Never position the appliance directly above the batteries.

The MultiPlus-II is suitable for wall mounting. A solid surface suitable for the weight and dimensions of the product must be available (e.g., concrete or masonry). For mounting purposes, a hook and two holes are provided at the back of the casing (see Appendix G).



The interior of the product must remain accessible after installation.

Try to keep the distance between the product and the battery to a minimum in order to minimise cable voltage losses.



For safety purposes, this product should be installed in a heat-resistant environment. You should prevent the presence of chemicals, synthetic components, curtains or other textiles, etc., in the immediate vicinity.



Each system requires a method of disconnecting the AC and DC circuits. If the overcurrent protection device is a circuit breaker, it will also serve as the disconnect. If fuses are used, separate disconnect switches will be needed between the source and the fuses.



To reduce the risk of fire, do not connect to an AC load centre (circuit breaker panel) with multiwire branch circuits.



CAUTION – To reduce the risk of injury, charge only Lead Acid or LiFePO₄-type rechargeable batteries. Other types of batteries may burst, causing personal injury and damage. Do not try to recharge non-rechargeable batteries.



Use of an attachment not recommended or sold by the marine unit manufacturer may result in a risk of fire, electric shock, or injury to persons



WARNING – RISK OF EXPLOSIVE GASES) WORKING IN THE VICINITY OF A LEAD-ACID BATTERY IS DANGEROUS. BATTERIES GENERATE EXPLOSIVE GASES DURING NORMAL BATTERY OPERATION. FOR THIS REASON, IT IS OF UTMOST IMPORTANCE THAT EACH TIME BEFORE SERVICING THE UNIT IN THE VICINITY OF THE BATTERY, YOU READ THIS MANUAL AND FOLLOW THE INSTRUCTIONS EXACTLY.

PERSONAL PRECAUTIONS

- Someone should be within range of your voice or close enough to come to your aid when you work near a lead-acid battery
- Have plenty of fresh water and soap nearby in case battery acid contacts skin, clothing, or eyes.
- Wear complete eye protection and clothing protection. Avoid touching your eyes while working near the battery.
- If battery acid contacts skin or clothing, wash immediately with soap and water. If acid enters the eye, immediately flood the eye with running cold water for at least 10 min and get medical attention immediately.
- NEVER smoke or allow a spark or flame in the vicinity of the battery or engine.
- Be extra cautious to reduce the risk of dropping a metal tool onto the battery. It might spark or short-circuit the battery or other electrical parts, which may cause an explosion.
- Remove personal metal items such as rings, bracelets, necklaces, and watches when working with a lead-acid battery. A lead-acid battery can produce a short-circuit current high enough to weld a ring or the like to metal, causing a severe burn.
- NEVER charge a frozen battery.
- If necessary, to remove the battery from the vessel, always remove the grounded terminal from the battery first. Make sure all accessories in the vessels are off so as not to cause an arc.
- Be sure the area around the battery is well-ventilated. Clean battery terminals. Be careful to keep corrosion from coming in contact with eyes. Study all battery manufacturers' specific precautions, such as removing or not removing cell caps while charging and recommended rates of charge.
- Clean battery terminals. Be careful to keep corrosion from coming in contact with eyes.
- Study all battery manufacturers' specific precautions, such as removing or not removing cell caps while charging and recommended rates of charge.

3.2. Mounting

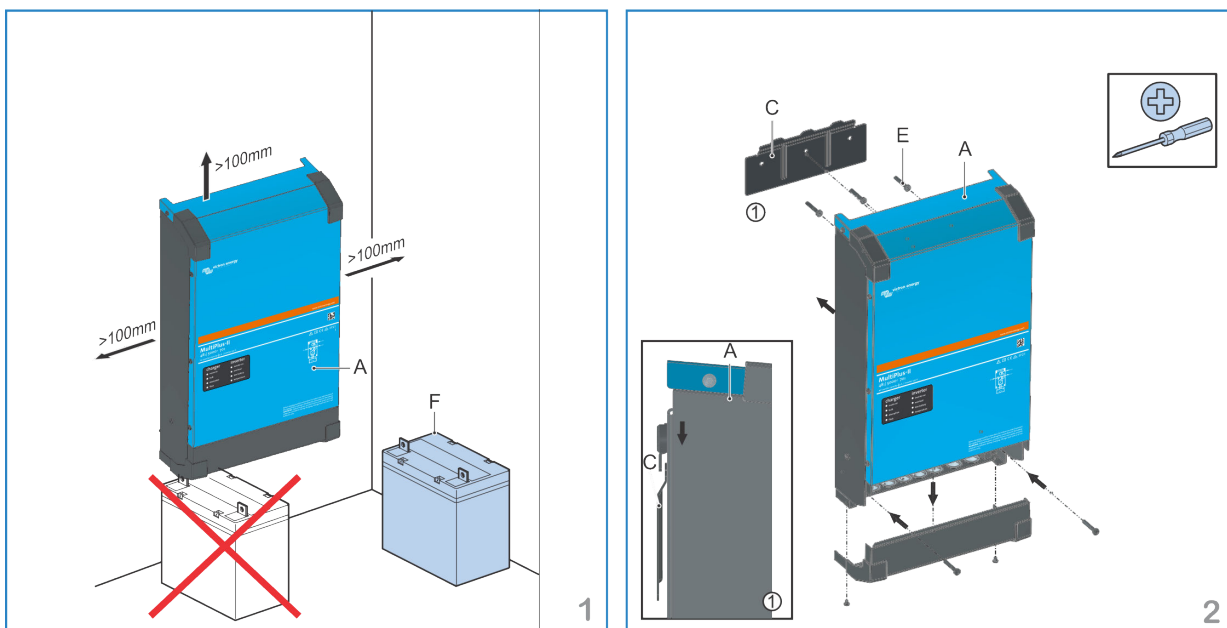

Refer to the [Dimensions \[44\]](#) chapter for the location and dimensions of the mounting holes.

3.3. DC connection

To fully utilise the product's capacity, use batteries with adequate capacity and cables with sufficient cross-section. The DC cables must be copper and rated for 90°C. Refer to the below table.

Model	Recommended battery capacity (Ah)	Recommended DC fuse current rating (A)	Recommended cross section (AWG) per + and - connection terminal *, **	Recommended cross section (AWG) per + and - connection terminal *, **
			0 – 5 m	5 – 10 m
48/3000/35	100 - 400	125	35 mm ²	70 mm ²
48/5000/70	200 - 800	200	70 mm ²	120 mm ²
48/8000/100	200 - 800	300	2x 50 mm ²	2x 70 mm ²
48/10000/140	250 - 1000	400	2x 50 mm ²	2x 70 mm ²
48/15000/200	300-1200	600	2x 95 mm ²	2x 150 mm ²

* Follow local installation rules.

** Do not locate battery cables in a closed conduit.

"2x" means two positive and two negative cables.

Remark: Internal resistance is an important factor when working with low-capacity batteries. Please consult your supplier or the relevant sections of our book 'Energy Unlimited', which is downloadable from our website.



The AC and DC terminals are suitable for copper cables rated at 90°C.



Device voltage class of Battery Terminal: DVC B

Connection Procedure

Proceed as follows to connect the battery cables:



Use a torque wrench with an insulated box spanner in order to avoid shorting the battery.

Recommended torque: 12 Nm (M8 nut)

Avoid shorting the battery cables.

- Undo the two screws at the bottom of the enclosure and remove the service panel.
- Connect the battery cables; see the appendix chapter for a connection overview.
- Tighten the nuts well for minimal contact resistance.
- The connector goes on first, then the flat washer, lock washer and nut. Tighten the nuts well for minimal contact resistance.

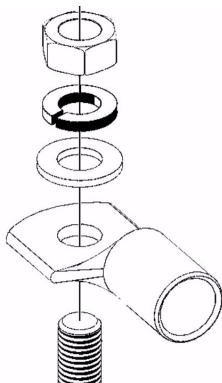

3.4. AC connection



A residual current device is mandatory for all domestic and residential installations below a 32A rating:

- Use for a 3kVA inverter/charger a 30mA, 32A, type A RCD.
- Use for a 5kVA inverter/charger a 30mA, 50A, type A RCD.
- Use for a 8, 10 or 15kVA inverter/charger a 30mA, 100A, type A RCD.

A fuse or automatic circuit breaker rated to support the expected load must be included in series with the output. And the cable cross-section must be sized accordingly.

Both the earth leakage circuit breaker, automatic circuit breaker (or fuse) and cabling must be in accordance with the AS/NZS 3000 Electrical installations standard.



In case of an earth fault alarm, the inverter/charger shuts down, and error 8 is raised. For more information about error 8, see [VE.Bus Error Codes](#).

An earth fault can be recognised if the inverter/charger has shut down. But to get a visual warning of the earth fault (error 8), the unit needs to be connected to a GX device, a Digital Multi Control panel or an external earth fault alarm device needs to be used.

If the unit is not connected to the (optional) VRM portal via an GX device, install the product in a high-traffic area where an alarm would be noticed, or install an additional external earth fault alarm unit.



This product is a safety class I product (supplied with a ground terminal for safety purposes). **Its AC input and/or output terminals and/or grounding point on the outside of the product must be provided with an uninterruptible grounding point for safety purposes.**

This product is provided with a ground relay (relay H, see appendix B) **that automatically connects the Neutral output to the chassis if no external AC supply is available.** If an external AC supply is provided, the ground relay H will open before the input safety relay closes. This ensures the correct operation of an earth leakage circuit breaker that is connected to the output.

- In a fixed installation, an uninterruptible grounding can be secured by means of the grounding wire of the AC input. Otherwise, the casing must be grounded.



The AC and DC terminals are suitable for copper cables rated at 90°C.



Device voltage class of AC Input Terminal: DVC C

Device voltage class of AC Out 1 and OUT 2 Terminal : DVC C

For the location of the AC terminals, see the appendix.

Special notes regarding AS 4777.2 (Australia/New Zealand):

1. In installations where the continuity of the neutral to the load may not be interrupted, the installer must place a wire between AC-in N and AC-out N. Additionally, grid code "Australia X: AS/NZS 4777.2:2020+A1+A2 stand alone app. M (with N-bypass)" must be chosen. In this case the Earth relay (ground relay) remains open and in pass through mode the internal neutral relay will not operate.

In this configuration, the installation must incorporate a single permanent MEN connection at the Main Switchboard (MSB). This connection provides the required neutral-to-earth reference and ensures the correct operation of RCDs.

Please see appendix for [grid connected wiring diagram \[37\]](#).

Please see appendix for [stand alone wiring diagram \[39\]](#).

Do not invert neutral and phase when connecting the AC.

• AC-in

The AC input cable can be connected to the terminal block 'AC-in'.

From left to right: "N" (neutral), "PE" (earth) and "L" (phase)

The AC input must be protected by a fuse or magnetic circuit breaker rated at 32A (for the 3kVA model), and 50A (for the 5kVA model) or less, and the cable cross-section must be sized accordingly. If the input AC supply is rated at a lower value, the fuse or magnetic circuit breaker should be downsized accordingly.

Generator connection requirements

- When a generator is connected to AC-in, an **isolated (floating neutral) generator** is the preferred arrangement.

- In this configuration the inverter's internal ground relay is not used and remains open. The installation must have a **single permanent MEN connection located at the Main Switchboard (MSB)**. This MEN connection provides the required neutral-to-earth reference and ensures the correct operation of RCDs. **Parallel MEN connections are not permitted.**
- **Neutral-earth bonded generators are not the preferred arrangement**, because they may create parallel MEN paths where a MEN connection already exists at the MSB. If a neutral-earth bonded generator is used, the bonding arrangement must be controlled by suitable switching or interlocking to ensure that **only one effective MEN connection exists at any given time.**

Please see appendix for the [generator connection diagram \[38\]](#).

• AC-out-1

The AC output cable can be connected directly to the terminal block 'AC-out'.

From left to right: "N" (neutral), "PE" (earth) and "L" (phase)

For a 3kVA unit with its PowerAssist feature enabled, the MultiPlus-II can add up to 3kVA to the output during periods of peak power requirement. Together with a maximum input current of 32A, this means that the output can supply up to $32 + 13 = 45A$.

For a 5kVA unit, the additional current is 22A, so the maximum output is $50 + 22 = 72A$.

For an 8kVA unit, the additional current is 29A, so the maximum output is $100 + 29 = 129A$.

For a 10kVA unit, the additional current is 36A, so the maximum output is $100 + 36 = 136A$.

For a 15kVA unit, the additional current is 45A, so the maximum output is $100 + 54 = 154A$.

An earth leakage circuit breaker and a fuse or circuit breaker rated to support the expected load must be included in series with the output, and the cable cross-section must be sized accordingly.

• AC-out-2

A second output is available that disconnects its load in the event of battery operation. On these terminals, equipment that may only operate if AC voltage is available on AC-in-1, e.g., an electric boiler or an air conditioner, is connected. The load on AC-out-2 is disconnected immediately when the MultiPlus-II switches to battery operation. After AC power becomes available on AC-in-1, the load on AC-out-2 will be reconnected with a delay of approximately 2 minutes. This allows a generator to stabilise.

3.5. Optional connections

A number of optional connections are possible.

For the location of the connection terminals, see the appendix chapter.

3.5.1. Remote control

The product can be remotely controlled in two ways.

- With an external switch. Operates only if the switch on the MultiPlus-II is set to "on".
- With a [Digital Multi Control](#) panel connected to one of the two RJ45 sockets. Operates only if the switch on the MultiPlus-II is set to "on".

3.5.2. Programmable relay

The product is equipped with a programmable relay.

The relay can be programmed for all kinds of applications, such as an alarm relay or a starter relay for a generator.

3.5.3. Programmable analogue/digital input/output ports

The product is equipped with two analogue/digital input/output ports.

These ports can be used for several purposes. One application is communication with the BMS of a lithium-ion battery.

3.5.4. Voltage sense

To compensate for possible cable losses during charging, two sense wires can be connected with which the voltage directly on the battery or on the positive and negative distribution points can be measured. Use wire with a cross-section of 0.75mm² (AWG 18).

During battery charging, the MultiPlus-II will compensate for the voltage drop over the DC cables up to a maximum of 1 Volt (i.e. 1V over the positive connection and 1V over the negative connection). If the voltage drop threatens to become larger than 1V, the charging current is limited in such a way that the voltage drop remains limited to 1V.

3.5.5. Temperature sensor

For temperature-compensated charging, a temperature sensor can be connected. The sensor is isolated and must be fitted to the negative terminal of the battery.



The temperature sensor is not supplied with 48V models.
It can be ordered separately. Order number: ASS000001000

3.5.6. Parallel connection



The 8, 10 and 15k units cannot be connected in parallel.

Up to six identical 3K or 5K units can be connected in parallel. When connecting them in parallel, the following requirements must be met:

- All units must be connected to the same battery.
- A maximum of six units can be connected in parallel.
- Only identical devices may be connected in parallel.
- The DC connection cables to the devices must be of equal length and cross-section.
- If a positive and a negative DC distribution point is used, the cross-section of the connection between the batteries and the DC distribution point must at least equal the sum of the required cross-sections of the connections between the distribution point and the units.
- Place the units close to each other, but allow at least 10cm for ventilation purposes under, above and beside the units.
- It is essential the negative battery terminal between the units is always connected. A fuse or circuit breaker is not allowed.
- UTP cables must be connected directly from one unit to another (and to the remote panel). Connection or splitter boxes are not permitted.
- Always interconnect the negative battery cables before placing the UTP cables.
- Only one remote control means (panel or switch) can be connected to the system.

For a connection diagram, see the [Parallel connection \[40\]](#) chapter

3.5.7. Three-phase operation

The MultiPlus-II can also be used in a 3-phase wye (Y) configuration. To this end, a connection between the devices is made by means of standard RJ45 UTP cables (the same as for parallel operation). The system (MultiPlus-II plus an optional Digital Multi Control panel) will require subsequent configuration (see the configuration chapter).

Pre-requisites: see the previous chapter.

Note: the MultiPlus-II is not suitable for the 3-phase delta (Δ) configuration.

For a connection diagram, see the [Three phase connection \[41\]](#) chapter.

4. Configuration



Settings may only be changed by a qualified electrical engineer.
Read the instructions thoroughly before implementing changes.
During charger configuration, the AC input must be removed.

4.1. Default settings

On delivery, the MultiPlus-II is set to default values. In general, these settings are suitable for single-unit operation.



Possibly, the standard battery charging voltage is not suitable for your batteries! Refer to the manufacturer's documentation or to your battery supplier!

Setting	Default value
Inverter frequency	50 Hz
Input frequency range	45 – 65 Hz
Input voltage range	187 - 250 VAC
Inverter voltage	230 VAC
Stand-alone / parallel / 3-phase	stand-alone
AES (Automatic Economy Switch)	off
Ground relay	on
Charger on/ off	on
Battery charge curve	four-stage adaptive with BatterySafe mode
Charging current	100% of the maximum charging current
Battery type	Victron Gel Deep Discharge (also suitable for Victron AGM Deep Discharge)
Automatic equalisation charging	off
Absorption voltage	57.6 V
Absorption time	up to 8 hours (depending on bulk time)
Float voltage	55.2 V
Storage voltage	52.8 V (not adjustable)
Repeated absorption time	1 hour
Absorption repeat interval	7 days
Bulk protection	on
AC input current limit	32 A for 3kVA and 50 A for 5kVA (Is adjustable for PowerControl and PowerAssist functions)
UPS feature	on
Dynamic current limiter	off
WeakAC	off
BoostFactor	2
Programmable relay	alarm function
PowerAssist	on

4.2. Configuring

To configure the inverter/charger the following hardware is required:

- [Interface MK3-USB](#) - to convert VE.Bus to USB
- [RJ45 UTP cable](#) - to connect the inverter/charger to the interface.

4.2.1. Set the grid code

To set the grid code, do the following:

1. Download and install the [VE.Configuration tools for VE.Bus products](#) software package on a Windows PC.
2. Connect the unit to the PC's USB port using the [Interface MK3-USB](#) and an [RJ45 UTP cable](#).
3. Open the VEConfigure3 software program (this is part of the configuration tool package).
4. Connect to the unit.
5. In the menu, go to port selection and click on the appropriate com port.
6. When connected, go to the "grid" tab.
7. Select the appropriate AS/NZS 4777.2020 grid code. Note that there are grid codes with or without N-bypass. Use N-bypass if the installation contains a continuous neutral whereby the AC input neutral is connected to the AC output neutral. Also, please refer to the "Special notes regarding AS 4777.2" in [Section 3.4 \[9\]](#).
8. Click the "Send settings" button to upload the grid code into the unit.

4.2.2. ESS configuration

If the unit is going to be used in an energy storage system (ESS), then follow the instructions in the [ESS design and installation manual](#).

4.2.3. VictronConnect

The VictronConnect app can be used to change most inverter/charger settings. See the [VictronConnect manual](#) for more information on how to install it, how to pair it with your device, and how to update the firmware.

This app can also set up parallel or 3-phase systems containing up to 3 units.

Note that this app cannot be used to change the grid code.

4.2.4. VEConfigure

VE.Configure is a software program that can be used to change all inverter/charger settings. See the [VEConfigure manual](#) for more information.

It is part of the "VE Configuration tools for VE.Bus Products" software package and can be downloaded free of charge at <https://www.victronenergy.com/support-and-downloads/software#ve-configuration-tools-for-ve-bus-products>

The inverter's grid code settings can be viewed using the VEConfigure software when connected to a Windows PC.

4.2.5. VE.Bus Quick Configure Setup

VE.Bus Quick Configure Setup is a software program with which systems with a maximum of three Multis (parallel or three-phase operation) can be configured in a simple manner.

It is part of the "VE Configuration tools for VE.Bus Products" software package and can be downloaded free of charge at <https://www.victronenergy.com/support-and-downloads/software#ve-configuration-tools-for-ve-bus-products>

4.2.6. VE.Bus System Configurator

For configuring advanced applications and/or systems with four or more Multis, **VE.Bus System Configurator** software must be used.

It is part of the "VE Configuration tools for VE.Bus Products" software package and can be downloaded free of charge at <https://www.victronenergy.com/support-and-downloads/software#ve-configuration-tools-for-ve-bus-products>

4.3. Explanation of settings

Settings that are not self-explanatory are described briefly below. For further information, please refer to the help files in the software configuration programs.

Inverter frequency

Output frequency if no AC is present at the input.

The output voltage of the MultiPlus-II in battery operation.

Inverter voltage

Adjustability: 50 Hz; 60 Hz

Adjustability: 210 – 245V

Country / grid code standard

For generator use, leave this setting at "None: feeding energy DC to grid not allowed".

Accept wide input frequency range



This setting is disabled when a grid code has been set.

Input frequency range accepted by the MultiPlus-II. It synchronises within this range with the AC input frequency. The output frequency is then equal to the input frequency.

Adjustability: 50, 60 or 45 – 65 Hz.

Input voltage range



This setting is disabled when a grid code has been set.

Voltage range accepted by the MultiPlus-II. It synchronises within this range with the AC input. The output voltage is then equal to the input voltage.

Adjustability: Lower limit: 180 – 230 V
Upper limit: 230 – 270 V



The standard lower limit setting of 180V is intended for connection to a generator with unstable AC output. This setting may result in a system shut down when connected to a 'brushless, self-excited, externally voltage regulated, synchronous AC generator' (synchronous AVR generator). Most generators rated at 10kVA or more are synchronous AVR generators. The shutdown is initiated when the generator is stopped and revs down while the AVR simultaneously 'tries' to keep the output voltage of the generator at 230V.

The solution is to increase the lower limit setting to 220Vac (the output of AVR generators is generally very stable), or to disconnect the MultiPlus-II from the generator when a generator stop signal is given (with help of an AC contactor installed in series with the generator).

Stand-alone/parallel operation / 2-phase / 3-phase setting

Using several devices, it is possible to:

- Increase total inverter power (several devices in parallel)
- Create a split-phase system with a separate autotransformer: see the Victron [Autotransformer product page](#).
- Create a 3-phase system.

The standard product settings are for standalone operation. For parallel, three-phase or split-phase operation, see the [VE.Bus manual parallel and 3-phase systems](#).

AES (Automatic Economy Switch)

If this setting is turned 'on', the power consumption in no-load operation and with low loads is decreased by approximately 20%, by slightly 'narrowing' the sinusoidal voltage. Applicable in stand-alone configuration only.

Search Mode

Instead of the AES mode, the **search mode** can also be chosen. If search mode is 'on', the power consumption in no-load operation is decreased by approximately 70%. In this mode the MultiPlus-II, when operating in inverter mode, is switched off in case of no load or very low load, and switches on every two seconds for a short period. If the output current exceeds a set level, the inverter will continue to operate. If not, the inverter will shut down again.

The Search Mode 'shut down' and 'remain on' load levels can be set with VEConfigure.

The standard settings are:

Shut down: 40 Watt (linear load)

Turn on: 100 Watt (linear load)

Ground relay (see appendix B)

With this relay, the neutral conductor of the AC output is grounded to the chassis when the back feed safety relays are open.

This ensures the correct operation of earth leakage circuit breakers in the output. If required, an external ground relay can be connected (for a split-phase system with a separate autotransformer). See the [Block diagram \[40\]](#) chapter.

Please refer to the "Special notes regarding AS 4777.2" in [Section 3.4 \[9\]](#).

Battery charge algorithm

The standard setting is 'Four-stage adaptive with BatterySafe mode'. See Section 2 for a description.

This is the recommended charge algorithm for lead acid batteries. See the help files in the software configuration programs for other features.

Battery type

The standard setting is the most suitable for Victron Gel Deep Discharge, Gel Exide A200, and tubular plate stationary batteries (OPzS).

This setting can also be used for many other batteries, e.g. Victron AGM Deep Discharge and other AGM batteries, and many types of flat-plate flooded batteries.

With VEConfigure, the charge algorithm can be adjusted to charge any battery type (Nickel Cadmium batteries, Lithium-ion batteries).

Absorption time

In case of the standard-setting 'Four-stage adaptive with BatterySafe mode' the absorption time depends on the bulk time (adaptive charge curve), so that the battery is optimally charged.

Automatic equalisation charging

This setting is intended for flooded tubular plate traction or OPzS batteries. During absorption, the voltage limit increases to 2.83V/cell (34V for a 24V battery) once the charge current has tapered down to less than 10% of the set maximum current.

Not adjustable with DIP switches.

See 'tubular plate traction battery charge curve' in VEConfigure.

Storage voltage, Repeated Absorption Time, Absorption Repeat Interval

See the Description chapter.

Bulk Protection

When this setting is 'on', the bulk charging time is limited to 10 hours. A longer charging time could indicate a system error (e.g. a battery cell short-circuit).

AC input current limit

These are the current limit settings for which PowerControl and PowerAssist come into operation:

Inverter rating	PowerAssist setting range, grid in-line topology	PowerAssist setting range, grid parallel topology with external 100A current transformer
3000VA	4 – 32A	4 - 50A
5000VA	6 - 50A	6 - 100A
8, 10 or 15kVA	11 - 100A	11-100A

Factory setting: maximum grid in-line topology value.

UPS feature

If this setting is 'on' and AC on the input fails, the MultiPlus-II switches to inverter operation practically without interruption.

The output voltage of some small generator sets is too unstable and distorted for using this setting – the MultiPlus-II would continually switch to inverter operation. For this reason, the setting can be turned off. The MultiPlus-II will then respond less quickly to AC input voltage deviations. The switchover time to inverter operation is consequently slightly longer, but most equipment (most computers, clocks or household equipment) is not adversely impacted.

Recommendation: Turn the UPS feature off if the MultiPlus-II fails to synchronise or continually switches back to inverter operation.

Dynamic current limiter

This setting is intended for generators where the AC voltage is generated by means of a static inverter (so-called 'inverter' generators). In these generators, engine rpm is reduced in case of low load: this reduces noise, fuel consumption and pollution. A disadvantage is that the output voltage will drop severely or even completely fail in the event of a sudden load increase. More load can only be supplied after the engine is up to speed.

If this setting is 'on', the MultiPlus-II will start supplying extra power at a low generator output level and gradually allow the generator to supply more until the set current limit is reached. This allows the generator engine to get up to speed.

This setting is also often used for 'classical' generators that respond slowly to sudden load variation.

Weak AC

This setting is for use with generators. Strong distortion of the input voltage can result in the charger hardly operating or not operating at all. If WeakAC is set, the charger will also accept a strongly distorted voltage at the cost of greater distortion of the input current.

Recommendation: Turn WeakAC on if the charger is hardly charging or not charging at all (which is quite rare!). Also, turn on the dynamic current limiter simultaneously and reduce the maximum charging current to prevent overloading the generator if necessary.



When WeakAC is on, the maximum charge current is reduced by approximately 20%.

BoostFactor

Change this setting only after consulting with Victron Energy or with an engineer trained by Victron Energy!

Programmable relay

The relay can be programmed for all kinds of other applications, for example, as a starter relay for a generator.

Auxiliary AC output (AC-out-2)

This output is intended for non-critical loads. It is directly connected to the AC input and is included in the current measurement circuit to enable PowerAssist.

4.4. Firmware

It is not necessary to update the unit to the latest firmware version. Stable systems should be left with their current firmware.

For information on firmware and for instructions on how to view the firmware version refer to the [VictronConnect configuration guide for VE.Bus products](#) document.

5. Operation

5.1. On/off/charger-only switch

When switched to 'on', the MultiPlus-II is fully functional. The inverter will come into operation, and the LED 'inverter on' will light up.

An AC voltage connected to the AC input terminal will be switched through to the AC output terminal, if within specifications. The inverter will switch off, the 'mains on' LED will light up, and the charger commences charging. The 'bulk', 'absorption' or 'float' LEDs will light up, depending on the charger mode.

If the voltage at the 'AC-in' terminal is rejected, the inverter will switch on.

When the switch is switched to 'charger only', only the battery charger of the MultiPlus-II will operate (if an AC voltage is present). In this mode, the AC input voltage is also switched through to the 'AC out' terminal.

NOTE: When only the charger function is required, ensure that the switch is switched to 'charger only'. This prevents the inverter from being switched on if the AC input voltage is lost, thus preventing your batteries from running flat.

5.2. Remote control

The product can be remotely controlled in two ways.

- With an external switch. For the switch to operate the switch on the Multiplus-II needs to be set to "on".
- With a [Digital Multi Control](#) panel. For the panel to operate the switch on the Multiplus-II needs to be set to "on".

5.3. LED Indications

- ● ● LEDs off
- ● ● LEDs blinking
- ● ● LEDs illuminated

<div style="display: flex; justify-content: space-between;"> <div style="width: 45%;"> <p>charger</p> <ul style="list-style-type: none"> ● mains on ● bulk ● absorption ● float </div> <div style="width: 45%;"> <p>inverter</p> <ul style="list-style-type: none"> ● inverter on ● overload ● low battery ● temperature </div> </div>	<p>Inverting</p> <p>The inverter is on. Inverter power is supplied to the load. The "inverter" LED is on.</p>
<div style="display: flex; justify-content: space-between;"> <div style="width: 45%;"> <p>charger</p> <ul style="list-style-type: none"> ● mains on ● bulk ● absorption ● float </div> <div style="width: 45%;"> <p>inverter</p> <ul style="list-style-type: none"> ● inverter on ● overload ● low battery ● temperature </div> </div>	<p>Overload pre-alarm</p> <p>The nominal output of the inverter is exceeded. The "overload" LED is blinking</p>
<div style="display: flex; justify-content: space-between;"> <div style="width: 45%;"> <p>charger</p> <ul style="list-style-type: none"> ● mains on ● bulk ● absorption ● float </div> <div style="width: 45%;"> <p>inverter</p> <ul style="list-style-type: none"> ● inverter on ● overload ● low battery ● temperature </div> </div>	<p>Overload alarm</p> <p>The inverter is switched off due to overload or short circuit. The "overload" LED is on.</p>

<p>charger</p> <ul style="list-style-type: none"> <input type="radio"/> mains on <input type="radio"/> bulk <input type="radio"/> absorption <input type="radio"/> float <p>inverter</p> <ul style="list-style-type: none"> <input checked="" type="radio"/> inverter on <input type="radio"/> overload <input type="radio"/> low battery <input type="radio"/> temperature 	<p>Low battery pre-alarm</p> <p>The battery voltage is getting low. The battery is almost fully exhausted. The "low battery" LED is blinking.</p>
<p>charger</p> <ul style="list-style-type: none"> <input type="radio"/> mains on <input type="radio"/> bulk <input type="radio"/> absorption <input type="radio"/> float <p>inverter</p> <ul style="list-style-type: none"> <input checked="" type="radio"/> inverter on <input type="radio"/> overload <input checked="" type="radio"/> low battery <input type="radio"/> temperature 	<p>Low battery alarm</p> <p>The inverter has switched off due to low battery voltage. The "low battery" LED is blinking.</p>
<p>charger</p> <ul style="list-style-type: none"> <input type="radio"/> mains on <input type="radio"/> bulk <input type="radio"/> absorption <input type="radio"/> float <p>inverter</p> <ul style="list-style-type: none"> <input checked="" type="radio"/> inverter on <input type="radio"/> overload <input type="radio"/> low battery <input checked="" type="radio"/> temperature 	<p>Temperature pre-alarm</p> <p>The internal temperature is reaching a critical level. The "temperature" LED is blinking.</p>
<p>charger</p> <ul style="list-style-type: none"> <input type="radio"/> mains on <input type="radio"/> bulk <input type="radio"/> absorption <input type="radio"/> float <p>inverter</p> <ul style="list-style-type: none"> <input checked="" type="radio"/> inverter on <input type="radio"/> overload <input type="radio"/> low battery <input checked="" type="radio"/> temperature 	<p>Temperature alarm</p> <p>The inverter has switched off due it's internal temperature being too high. The "temperature" LED is on.</p>
<p>charger</p> <ul style="list-style-type: none"> <input type="radio"/> mains on <input type="radio"/> bulk <input type="radio"/> absorption <input type="radio"/> float <p>inverter</p> <ul style="list-style-type: none"> <input checked="" type="radio"/> inverter on <input checked="" type="radio"/> overload <input checked="" type="radio"/> low battery <input type="radio"/> temperature 	<p>Overload pre-alarm and low battery pre-alarm</p> <p>The battery is nearly exhausted and the nominal output of the inverter is exceeded. The "overload" and "low battery" LEDs are both blinking alternately,</p>
<p>charger</p> <ul style="list-style-type: none"> <input type="radio"/> mains on <input type="radio"/> bulk <input type="radio"/> absorption <input type="radio"/> float <p>inverter</p> <ul style="list-style-type: none"> <input checked="" type="radio"/> inverter on <input checked="" type="radio"/> overload <input checked="" type="radio"/> low battery <input type="radio"/> temperature 	<p>Ripple pre-alarm</p> <p>The ripple voltage on the battery terminals is too high. The "overload" and "low battery" LEDs are both blinking simultaneously.</p>

<p>charger</p> <ul style="list-style-type: none"> <input type="radio"/> mains on <input type="radio"/> bulk <input type="radio"/> absorption <input type="radio"/> float <p>inverter</p> <ul style="list-style-type: none"> <input checked="" type="radio"/> inverter on <input type="radio"/> overload <input type="radio"/> low battery <input type="radio"/> temperature 	<p>Ripple alarm</p> <p>The inverter has switched off due to excess ripple voltage on the battery terminals. The "overload" and "low battery" LEDs are both on.</p>
<p>charger</p> <ul style="list-style-type: none"> <input checked="" type="radio"/> mains on <input checked="" type="radio"/> bulk <input type="radio"/> absorption <input type="radio"/> float <p>inverter</p> <ul style="list-style-type: none"> <input type="radio"/> inverter on <input type="radio"/> overload <input type="radio"/> low battery <input type="radio"/> temperature 	<p>Bulk charging</p> <p>The AC input voltage is switched through and the charger operates in bulk mode. The "bulk" LED is on.</p>
<p>charger</p> <ul style="list-style-type: none"> <input checked="" type="radio"/> mains on <input checked="" type="radio"/> bulk <input checked="" type="radio"/> absorption <input type="radio"/> float <p>inverter</p> <ul style="list-style-type: none"> <input type="radio"/> inverter on <input type="radio"/> overload <input type="radio"/> low battery <input type="radio"/> temperature 	<p>BatterySafe</p> <p>The mains voltage is switched through and the charger is on. However, the set absorption voltage has not yet been reached. The "bulk" and "absorption" LEDs are both on.</p>
<p>charger</p> <ul style="list-style-type: none"> <input checked="" type="radio"/> mains on <input type="radio"/> bulk <input checked="" type="radio"/> absorption <input type="radio"/> float <p>inverter</p> <ul style="list-style-type: none"> <input type="radio"/> inverter on <input type="radio"/> overload <input type="radio"/> low battery <input type="radio"/> temperature 	<p>Absorption charging</p> <p>The mains voltage is switched through and the charger operates in absorption mode. The "absorption" LED is on.</p>
<p>charger</p> <ul style="list-style-type: none"> <input checked="" type="radio"/> mains on <input type="radio"/> bulk <input type="radio"/> absorption <input checked="" type="radio"/> float <p>inverter</p> <ul style="list-style-type: none"> <input type="radio"/> inverter on <input type="radio"/> overload <input type="radio"/> low battery <input type="radio"/> temperature 	<p>Float charging</p> <p>The mains voltage is switched through and the charger operates in float mode. The "float" LED is on.</p>
<p>charger</p> <ul style="list-style-type: none"> <input checked="" type="radio"/> mains on <input checked="" type="radio"/> bulk <input checked="" type="radio"/> absorption <input type="radio"/> float <p>inverter</p> <ul style="list-style-type: none"> <input type="radio"/> inverter on <input type="radio"/> overload <input type="radio"/> low battery <input type="radio"/> temperature 	<p>Equalize charging</p> <p>The mains voltage is switched through and the charger operates in equalize mode. The "bulk" and "absorption" LED are both blinking.</p>

charger		inverter	
<input checked="" type="radio"/> mains on	<input type="radio"/> bulk	<input type="radio"/> inverter on	<input type="radio"/> overload
<input type="radio"/> absorption	<input type="radio"/> float	<input type="radio"/> low battery	<input type="radio"/> temperature

PowerControl

The AC input is switched through. The AC output current is equal to the preset maximum input current. The charge current is reduced to 0A. The "mains on" LED is blinking.

charger		inverter	
<input checked="" type="radio"/> mains on	<input type="radio"/> bulk	<input checked="" type="radio"/> inverter on	<input type="radio"/> overload
<input type="radio"/> absorption	<input type="radio"/> float	<input type="radio"/> low battery	<input type="radio"/> temperature

PowerAssist

The AC input is switched through, but the load requires more current than the preset maximum input current. The inverter is switched on to supply the required additional current. The "mains on" LED is on and the "inverter" LED is blinking.

For more error codes see section 7.3

For the latest and most up to date information about the blink codes, please refer to the Victron Toolkit app.

Click on or scan the QR code to get to the Victron Support and Downloads/Software page.



5.4. Equalisation and forced absorption

5.4.1. Activating equalisation or forced absorption

The MultiPlus-II can be put into both these states from the remote panel as well as with the front panel switch, provided that all switches (front, remote, and panel) are set to 'on' and no switches are set to 'charger only'.

In order to put the MultiPlus-II in this state, the procedure below should be followed.

If the switch is not in the required position after following this procedure, it can be switched over quickly once. This will not change the charging state.



Switching from 'on' to 'charger only' and back, as described below, must be done quickly. The switch must be toggled such that the intermediate position is 'skipped', as it were. If the switch remains in the 'off' position even for a short time, the device may be turned off. In that case, the procedure must be restarted at step 1. A certain degree of familiarisation is required when using the front switch on the Compact in particular. When using the remote panel, this is less critical.

Procedure:

1. Check whether all switches (i.e. front switch, remote switch or remote panel switch if present) are in the 'on' position.
2. Activating equalisation or forced absorption is only meaningful if the normal charging cycle is completed (charger is in 'Float').
3. To activate:
 - a. Switch rapidly from 'on' to 'charger only' and leave the switch in this position for ½ to 2 seconds.
 - b. Switch rapidly back from 'charger only' to 'on' and leave the switch in this position for ½ to 2 seconds.
 - c. Switch once more rapidly from 'on' to 'charger only' and leave the switch in this position.

4. On the MultiPlus-II (and, if connected, on the MultiControl panel) the three LEDs 'Bulk', 'Absorption' and 'Float' will now flash 5 times.
5. Subsequently, the LEDs 'Bulk', 'Absorption' and 'Float' will each light during 2 seconds.
 - a. If the switch is set to 'on' while the 'Bulk' LED lights, the charger will switch to equalisation.
 - b. If the switch is set to 'on' while the 'Absorption' LED lights, the charger will switch to forced absorption.
 - c. If the switch is set to 'on' after the three LED sequence has finished, the charger will switch to 'Float'.
 - d. If the switch is has not been moved, the MultiPlus-II will remain in 'charger only' mode and switch to 'Float'.

5.4.2. Equalisation

Traction batteries require regular additional charging. In the equalisation mode, the MultiPlus-II will charge with increased voltage for one hour (1V above the absorption voltage for a 12V battery, 2V for a 24V battery). The charging current is then limited to 1/4 of the set value.

The 'bulk' and 'absorption' LEDs flash intermittently.



Equalisation mode supplies a higher charging voltage than most DC consuming devices can cope with. These devices must be disconnected before additional charging takes place.

5.4.3. Forced absorption

Under certain circumstances, it can be desirable to charge the battery for a fixed time at the absorption voltage level. In Forced Absorption mode, the MultiPlus-II will charge at the normal absorption voltage level during the set maximum absorption time.

The 'absorption' LED lights.

5.5. Shut down procedure

To switch the MultiPlus-II off, use the on/off/charger-only switch located on the bottom left-hand underside of the case. The middle position of the switch is the OFF position.

To completely de-power the MultiPlus-II, disconnect the DC fuse or turn off the isolation switch, DC contactor or DC circuit breaker, located between the battery and the DC terminals of the unit. Note that dangerous residual voltages may still exist inside the product and at its terminals after shutdown. Never open the product casing or touch bare terminals.

6. Maintenance

The MultiPlus-II does not require specific maintenance. It will suffice to check all connections once a year. Avoid moisture and oil/soot/vapours, and keep the device clean.

7. Troubleshooting

With the procedures below, most errors can be quickly identified. If an error cannot be resolved, please refer to your Victron Energy supplier.

Our recommendation is to use the Victron Toolkit app to find the description of all possible LED alarm codes. See here for download information: <https://www.victronenergy.com/support-and-downloads/software#victron-toolkit-app>.

7.1. General error indications

Problem	Cause	Solution
No output voltage on AC-out-2.	in inverter mode	
will not switch over to generator or mains operation.	Circuit breaker or fuse in the AC-in input is open as a result of overload.	Remove overload or short circuit on AC-out-1 or AC-out2, and reset fuse/breaker.
Inverter operation not initiated when switched on	The battery voltage is excessively high or too low. No voltage on DC connection.	Ensure that the battery voltage is within the correct range.
'Low battery' LED flashes	The battery voltage is low.	Charge the battery or check the battery connections.
Low battery' LED lights.	The converter switches off because the battery voltage is too low.	Charge the battery or check the battery connections.
'Overload' LED flashes.	The converter load is higher than the nominal load.	Reduce the load.
'Overload' LED lights	The converter is switched off due to excessively high load.	Reduce the load.
'Temperature' LED flashes or lights.	The environmental temperature is high, or the load is too high.	Install the converter in cool and well-ventilated environment, or reduce the load.
'Low battery' and 'overload' LEDs flash intermittently.	Low battery voltage and excessively high load.	Charge the batteries, disconnect or reduce the load, or install higher capacity batteries. Fit shorter and/or thicker battery cables.
'Low battery' and 'overload' LEDs flash simultaneously.	Ripple voltage on the DC connection exceeds 1.5 Vrms.	Check the battery cables and battery connections. Check whether battery capacity is sufficiently high, and increase this if necessary.
'Low battery' and 'overload' LEDs light.	The inverter is switched off due to an excessively high ripple voltage on the input.	Install batteries with a larger capacity. Fit shorter and/or thicker battery cables, and reset the inverter (switch off, and then on again).
One alarm LED lights and the second flashes.	The inverter is switched off due to alarm activation by the lighted LED. The flashing LED indicates that the inverter was about to switch off due to the related alarm.	Check this table for appropriate measures in regard to this alarm state.
The charger does not operate.	The AC input voltage or frequency is not within the range set.	Ensure that the AC input is between 185 VAC and 265 VAC, and that the frequency is within the range set (default setting 45-65 Hz).
	Circuit breaker or fuse in the AC-in input is open as a result of overload.	Remove overload or short circuit on AC-out-1 or AC-out-2, and reset fuse/breaker.
	The battery fuse has blown.	Replace the battery fuse.
	The distortion or the AC input voltage is too large (generally generator supply).	Turn the settings WeakAC and dynamic current limiter on.

Problem	Cause	Solution
The charger does not operate. 'Bulk' LED flashes and 'Mains on' LED illuminates	is in 'Bulk protection' mode thus, the maximum bulk charging time of 10 hours is exceeded. Such a long charging time could indicate a system error (e.g. a battery cell short-circuit).	Check your batteries.  You can reset the error mode by switching off and back on the . The standard factory setting of the 'Bulk protection' mode is switched on. The 'Bulk protection' mode can be switched off with help of VEConfigure only.
The battery is not completely charged.	Charging current excessively high, causing premature absorption phase.	Set the charging current to a level between 0.1 and 0.2 times the battery capacity.
	Poor battery connection.	Check the battery connections.
	The absorption voltage has been set to an incorrect level (too low).	Set the absorption voltage to the correct level.
	The float voltage has been set to an incorrect level (too low).	Set the float voltage to the correct level.
	The available charging time is too short to fully charge the battery.	Select a longer charging time or higher charging current.
	The absorption time is too short. For adaptive charging this can be caused by an extremely high charging current with respect to battery capacity, so that bulk time is insufficient.	Reduce the charging current or select the 'fixed' charging characteristics.
The battery is overcharged.	The absorption voltage is set to an incorrect level (too high).	Set the absorption voltage to the correct level.
	The float voltage is set to an incorrect level (too high).	Set the float voltage to the correct level.
	Poor battery condition.	Replace the battery.
	The battery temperature is too high (due to poor ventilation, excessively high environmental temperature, or excessively high charging current).	Improve ventilation, install batteries in a cooler environment, reduce the charging current, and connect the temperature sensor.
The charging current drops to 0 as soon as the absorption phase initiates.	The battery is over-heated (>50°C)	<ul style="list-style-type: none"> • Install the battery in a cooler environment • Reduce the charging current • Check whether one of the battery cells has an internal short circuit
	Defective battery temperature sensor	Disconnect the temperature sensor plug in the . If charging functions correctly after approximately 1 minute, the temperature sensor should be replaced.

7.2. Special LED indications

For the normal LED indications, see the previous chapter.

Problem	Cause
'Mains on' flashes and there is no output voltage	The device is in 'charger only' operation and mains supply is present. The device rejects the mains supply or is still synchronising.
Bulk and absorption LEDs flash synchronously (simultaneously).	Voltage sense error. The voltage measured at the voltage sense connection deviates too much (more than 7V) from the voltage on the positive and negative connection of the device. There is probably a connection error. The device will remain in normal operation.  If the "inverter on" LED flashes in phase opposition, this is a VE.Bus error code (see further on).

Problem	Cause
Absorption and float LEDs flash synchronously (simultaneously).	<p>The battery temperature as measured has an extremely unlikely value. The sensor is probably defective or has been incorrectly connected. The device will remain in normal operation.</p> <div style="border: 1px solid #0070C0; padding: 5px; margin-top: 10px;">  If the "inverter on" LED flashes in phase opposition, this a VE.Bus error code (see further on). </div>

7.3. VE.Bus LED indications

Equipment included in a VE.Bus system (a parallel or 3-phase arrangement) can provide so-called VE.Bus LED indications. These LED indications can be subdivided into two groups: OK codes and error codes.

7.3.1. VE.Bus OK codes

If the internal status of a device is in order but the device cannot yet be started because one or more other devices in the system indicate an error status, the devices that are in order will indicate an OK code. This facilitates error tracing in a VE.Bus system, since devices not requiring attention are easily identified as such.



OK codes will only be displayed if a device is not in inverter or charging operation!

- A flashing 'bulk' LED indicates that the device can perform inverter operation.
- A flashing 'float' LED indicates that the device can perform charging operation.



In principle, all other LEDs must be off. If this is not the case, the code is not an OK code. However, the following exceptions apply:

- The special LED indications above can occur together with the OK codes.
- The 'low battery' LED can function together with the OK code that indicates that the device can charge.

7.3.2. VE.Bus error codes

A VE.Bus system can display various error codes. These codes are displayed with the "inverter on", "bulk", "absorption" and "float" LEDs.

To interpret a VE.Bus error code correctly, the following procedure should be followed:

1. The device should be in error (no AC output).
2. Is the 'inverter on' LED flashing? If not, then there is no VE.Bus error code.
3. If one or more of the LEDs 'bulk', 'absorption' or 'float' flashes, then this flash must be in phase opposition to the 'inverter on' LED, i.e. the flashing LEDs are off if the 'inverter on' LED is on, and vice versa. If this is not the case, then there is no VE.Bus error code.
4. Check the 'bulk' LED, and determine which of the three tables below should be used.
5. Select the correct column and row (depending on the 'absorption' and 'float' LEDs), and determine the error code. 6. Determine the meaning of the code in the tables below.
6. Determine the meaning of the code in the tables below.

All of the conditions below must be met!:







1. The device is in error! (No AC output)
2. Inverter LED flashes (in opposition to any flashing of the Bulk, Absorption or Float LED)
3. At least one of the LEDs Bulk, Absorption and Float is on or flashing

Bulk LED off		Absorption LED		
		off	flashing	on
Float LED	off	0	3	6
	flashing	1	4	7
	on	2	5	8

Bulk LED flashes		Absorption LED		
		off	flashing	on
Float LED	off	9	12	15
	flashing	10	13	16
	on	11	14	17

Bulk LED on		Absorption LED		
		off	flashing	on
Float LED	off	18	21	24
	flashing	19	22	25
	on	20	23	26

Bulk LED Absorption LED Float LED	Code	Meaning:	Cause/solution:
○ ○ ☀	1	Device is switched off because one of the other phases in the system has switched off.	Check the failing phase.
○ ☀ ○	3	Not all, or more than, the expected devices were found in the system.	The system is not properly configured. Reconfigure the system. Communication cable error. Check the cables and switch all equipment off, and then on again.
○ ☀ ☀	4	No other device whatsoever detected	Check the communication cables.
○ ☀ ☀	5	Overvoltage on AC-out.	Check the AC cables.
☀ ○ ☀	10	System time synchronisation problem occurred.	Should not occur in correctly installed equipment. Check the communication cables.

Bulk LED Absorption LED Float LED	Code	Meaning:	Cause/solution:
	14	Device cannot transmit data.	Check the communication cables (there may be a short circuit)
	17	One of the devices has assumed 'master' status because the original master failed.	Check the failing unit. Check the communication cables.
	18	Overvoltage has occurred	Check AC cables.
	22	This device cannot function as 'slave'.	This device is an obsolete and unsuitable model. It should be replaced
	24	Switch-over system protection initiated.	Should not occur in correctly installed equipment. Switch all equipment off, and then on again. If the problem recurs, check the installation. Possible solution: increase lower limit of AC input voltage to 210 VAC (factory setting is 180 VAC)
	25	Firmware incompatibility. The firmware of one the connected devices is not sufficiently up to date to operate in conjunction with this device.	<ol style="list-style-type: none"> 1. Switch all equipment off. 2. Switch the device returning this error message on. 3. Switch on all other devices one by one until the error message reoccurs. 4. Update the firmware in the last device that was switched on.
	26	Internal error.	Should not occur. Switch all equipment off, and then on again. Contact Victron Energy if the problem persists.

8. Support

For support, follow the following steps.

1. Consult the [Troubleshooting \[23\]](#) chapter in this manual.
2. Check our [Community knowledge base](#). Scan through popular questions and answers or ask the community of experts.
3. For installers: to verify if the inverter/charger is faulty, follow the [Pre-RMA_Bench_Test_Instructions - Inverter-charger](#) test instructions:
4. Contact your Victron installer, dealer or distributor. They are all trained in technical support and can action warranty claims. For a list of our distributors, see the [Where to buy](#) page on our website.
5. If the Victron distributor is unknown. Enter your serial number into our [Support](#) web page, so we can connect you to the original dealer for support, repairs and warranty requests.

9. Warranty

9.1. Victron Energy limited warranty policy

Direct Customers

Victron Energy provides the following warranty to any direct customer (OEM, distributor or dealer) in relation to any products that Victron Energy has directly sold to the direct customer. This warranty is not an end-user warranty between Victron Energy and an end-user, and end-users shall not have any rights or remedies under this limited warranty towards Victron Energy directly.

The direct customer shall, in turn, ensure that the end-user is provided with a warranty identical to this warranty, subject to applicable local mandatory law.

End-Users

Victron Energy may also provide a warranty directly to end-users, in which case the below warranty conditions equally apply to such warranty. In that case, end-users shall claim their warranty at their place of purchase or through the original direct customer of Victron, which can be found through the support section on Victron's website (<https://www.victronenergy.com/support>). Hence, the direct customer shall on behalf of Victron Energy deal with any warranty claims made under any warranty that Victron Energy may provide directly to end-users. This support section on Victron's website (<https://www.victronenergy.com/support>) will provide further guidance on the procedure for end-users to make a claim under this limited warranty.

If the end-user is a consumer – a natural person who is acting for purposes which are outside that person's trade, business, craft or profession – the following applies. The rights and remedies granted to the consumer under this limited warranty are without prejudice to the consumer's statutory rights. Furthermore, the consumer is entitled by law to remedies from the seller free of charge in the event of a lack of conformity of the goods (such as repair, replacement, price reduction or rescission), which remedies are not affected by this limited warranty.

Warranty

Victron Energy warrants its products to be free from defects in workmanship and materials for a period of 5 years from the date of purchase by the original end-user, with a maximum of 66 months from the Victron Energy invoice date. Exceptions on this are: lead-acid batteries: 2 years from date of purchase by the original end-user, with a maximum of 30 months from the Victron Energy invoice date, Lithium batteries: 3 years from date of purchase by the original end-user, with a maximum of 42 months from the Victron Energy invoice date. In addition to this, proof of correct battery usage is required when making a battery warranty claim.

For a 10% surcharge on the current net price for products that came with a 5-year warranty, an additional 5 years of warranty can be purchased by Victron's direct customers, bringing the total warranty to 10 years. Warranty extensions need to be applied for ultimately one year before the expiration of the original term. Victron may ask proof that the product was still functional at the time of purchase of the extended warranty.

During the warranty period, Victron Energy will, at its discretion, repair, replace or (partly) credit the defective product free of charge. The warranty does not include performing or reimbursing de-installation, transportation, and re-installation. This warranty will be considered void if the unit has suffered any physical damage or alteration, either internally or externally, and does not cover damages arising from improper use like:

- Reversed battery polarity.
- Inadequate connection.
- Mechanical shock or deformation.
- Contact with liquid or oxidation by condensation.
- Use in an inappropriate environment (dust, corrosive vapour, humidity, high temperature, biological infestation, etc.).
- Breakage or damage due to lightning.
- Connection terminals and screws destroyed or other damages, like overheating, due to insufficient tightening.
- For any electronic breakage except due to lightning (reverse polarity, over-voltage due to external cause), the state of the internal control diode and/or the input/output X and Y capacitors determine the warranty.

This warranty will not apply where the product has been misused, neglected, improperly installed, or repaired by anyone other than Victron Energy or one of its authorized Repair Centres. In order to qualify for the warranty, the product must not be disassembled or modified.

This warranty and our warranty obligations thereunder (repair, replacement or credit) are the direct customer's and, if applicable, the end-user's sole rights and remedies and our sole obligations with respect to any defective and/or non-conforming product or breach of warranty and is subject to and without prejudice to the limitations of liability in this warranty. Victron Energy shall not be liable for damages, whether direct, incidental, special, or consequential, even caused by negligence or fault.

As a product requires service, it must be brought back to the place of purchase. In case no contact can be made with the merchant, or if he is either unable or not allowed to provide service, direct contact should be made with Victron Energy through the support section on Victron's website.

In case Victron Energy replaces a product, it will own the replaced product. Victron Energy owns all parts removed from repaired products. Victron Energy uses new or reconditioned parts made by various manufacturers when performing warranty repairs or building replacement products. If Victron Energy repairs or replaces a part of a product, its warranty term is not extended: the warranty will apply for the remaining term of the original warranty term. For example, if Victron Energy replaces a product with a 5-year warranty after 3 years, the warranty of this product will apply for another 2 years, with a minimum of 6 months.

All remedies and the measure for damages are limited to the above.

Victron Energy shall in no event be liable for consequential, incidental, contingent or special damages, even if having been advised of the probability of such damages.

The foregoing limited warranty provided by Victron Energy is in lieu of any other warranties, express or implied arising by law, course of dealing, course of performance, usage of trade or otherwise, of any kind whatsoever including, without limitation, warranties of merchantability or fitness for a particular purpose, with respect to any product.

The above is without prejudice to the arrangement for consumers detailed above.

Life Support Policy

As a general policy, Victron Energy does not recommend the use of any of its products in life support applications where failure or malfunction of Victron Energy's product can be reasonably expected to cause the failure of the life support device or to significantly affect its safety or effectiveness. Victron Energy does not recommend the use of any of its products in direct patient care. Victron Energy will not knowingly sell its products for use in such applications unless it receives in writing assurances satisfactory to Victron Energy that the risks of injury or damage have been minimized, the customer assumes all such risks, and the liability of Victron Energy is adequately protected under the circumstances.

Warranty on repairs for products outside their warranty period

The warranty period on products that are outside their warranty period and have been repaired by Victron Energy or one of the Victron Energy Repair centres is six (6) months from delivery. The same applies to spare parts and circuit boards that have been supplied or repaired by Victron Energy.

Transport

It is the responsibility of the sender to sufficiently package these products. The transport must be organized in a way to avoid any damage, especially when a single unit or heavy unit is sent.

Severability

If a part of the terms and conditions of this warranty is held invalid, void or unenforceable due to any particular national or international legislation, it shall not affect other parts of the terms and conditions of this warranty.

Applicable law

This warranty is exclusively governed by the laws of the Netherlands, to the exclusion of the UN Convention on Contracts for the International Sale of Goods.

Contact details

Victron Energy B.V. | De Paal 35, 1351 JG Almere, The Netherlands | <https://www.victronenergy.com/support>

9.2. Australian warranty statement

Our goods come with guarantees that cannot be excluded under the Australian Consumer Law. You are entitled to a replacement or refund for a major failure and compensation for any other reasonably foreseeable loss or damage. You are also entitled to have the goods repaired or replaced if the goods fail to be of acceptable quality and the failure does not amount to a major failure.

10. Technical specifications

10.1. Technical specifications

MultiPlus-II 230V	48/3000/35-32	48/5000/70-50
PowerControl & PowerAssist	Yes	
Transfer switch	32A	50A
Maximum AC input current	32A	50A
Type of electrical supply system to be connected	TN/TT	
INVERTER		
DC Input voltage range	38 – 66 V	
AC Output voltage	230 V ± 2%	
AC output frequency	50 Hz ± 0,1% (1)	
AC output current	11A	19A
Continuous output power at 25°C (3)	3000 VA	5000 VA
Continuous. output power at 25°C	2400 W	4000 W
Continuous. output power at 40°C	2200 W	3700 W
Continuou. output power at 65°C	1700 W	3000 W
Max apparent feed-in power	3000 VA	5000 VA
Peak power	5500 W	9000 W
Maximum output fault current	32A for 1s	53A for 1s
Maximum output over current protection	32A	53A
Overvoltage category for all ports	OVC III	
Active anti-islanding method	Frequency Shift method	
Maximum battery discharge current	75A	110A
Maximum efficiency	95%	96%
Zero load power	11 W	18 W
Zero load power in AES mode	7 W	12 W
Zero load power in Search mode	2 W	2 W
Inverter topology	Isolated	
CHARGER		
AC Input voltage range GENERAL	187-250 V	
AC Input frequency range	45 – 65 Hz	
Charge voltage 'absorption'	57.6 V	
Charge voltage 'float'	55.2 V	
Storage mode	52.8 V	
Max. battery charge current (4)	35 A	70 A
Battery temperature sensor	Optional. Order number: ASS000001000	
Compatible battery chemistries	Lead-acid, Lithium, Zinc-Bromine and others (5)	
GENERAL		
Auxiliary AC output	Yes (32A)	
External AC current sensor (optional)	100A	

MultiPlus-II 230V	48/3000/35-32	48/5000/70-50
Programmable relay (6)	Yes	
Protection (2)	a - g	
VE.Bus communication port	Yes	
General purpose communication port	Yes, 2x	
Remote on/off terminal	Yes	
Operating temperature range	-20 to +65°C (fan assisted cooling)	
Rated short-time withstand current (I _{cw})	6kA	
Humidity (non-condensing)	max 95%	
Environmental category	Indoor conditional	
Pollution degree	2	
Maximum altitude	2000m	
Country of manufacture	China	India
ENCLOSURE		
Material and colour	Steel, blue RAL 5012	
Protection category	IP21	
Battery connection	M8 bolts	
AC connection	Screw terminals for wire up to 13mm ² (6 AWG)	
Weight	18 kg	29 kg
Dimensions h _w xw _d (mm)	506 x 275 x 147	565 x 320 x 148
STANDARDS		
Safety	EN-IEC 60335-1, EN-IEC 60335-2-29, EN-IEC 62109-1, EN-IEC 62109-2 AS 62477.1:2016, AS/NZS.2:2020 Inc A1	
Emission, Immunity	EN 55014-1, EN 55014-2, EN-IEC 61000-3-2, EN-IEC 61000-3-3 IEC 61000-6-1, IEC 61000-6-2, IEC 61000-6-3	
1) Can be adjusted to 60Hz 2) Protection key: a) output short circuit b) overload c) battery voltage too high d) battery voltage too low e) temperature too high f) 230Vac on inverter output g) input voltage ripple too high	3) Non-linear load, crest factor 3:1 4) Up to 25°C ambient 5) Other chemistries are possible as well, provided the charger is configured to confirm the battery manufacturer's specifications. 6) A programmable relay can be set for a general alarm, DC under voltage, or a genset start/stop function. AC rating: 230V / 4A, DC rating: 4A up to 35VDC and 1A up to 60VDC	

10.2. Technical specifications

MultiPlus-II 230V AU	48/8000/110-100	48/10000/140-100	48/15000/200-100
PowerControl & PowerAssist	Yes		
Transfer switch	100A	100A	100A
Maximum AC input current	100A	100A	100A
Type of electrical supply system to be connected	TN/TT		
INVERTER			
DC Input voltage range	38 – 66 V		
AC Output voltage	230 V ± 2%		
AC output frequency	50 Hz ± 0,1% (1)		
AC output current	29A	36A	54A
Continuous output power at 25°C (3)	8000 VA	10000 VA	15000 VA
Continuous output power at 25°C	6400 W	8000 W	12000 W
Continuous output power at 40°C	5500 W	7000 W	10000 W
Continuous output power at 65°C	4000 W	6000 W	7000 W
Peak power	15000 W	18000 W	27000 W
Maximum output fault current	80A	100 A	150 A
Maximum output over current protection AC OUT 1	135A	143 A	165 A
Maximum output over current protection AC OUT 2	50A		
Overvoltage category for all ports	OVC III		
Active anti-islanding method	Frequency Shift method		
Maximum battery discharge current	188A	235A	350A
Maximum efficiency	95%	96%	95%
Zero load power	29 W	38 W	55 W
Zero load power in AES mode	19 W	27 W	39 W
Zero load power in Search mode	3 W	4 W	6 W
Inverter topology	Isolated		
CHARGER			
AC Input voltage range GENERAL	230V ±10%		
AC Input frequency range	45 – 65 Hz		
Maximum AC Input current while charging	27A	32A	48A
AC Input voltage – lower threshold for charging cutoff	210V		
Charge voltage 'absorption'	57.6 V		
Charge voltage 'float'	55.2 V		
Storage mode	52.8 V		
Max. battery charge current (4)	110 A	140 A	200 A
Battery temperature sensor	Optional. Order number: ASS000001000		
Compatible battery chemistries	Lead-acid, Lithium and others (5)		
GENERAL			
Auxiliary AC output	Yes (50A)		
AC output current with Power assist (AC Out 1)	129A	136A	154A
AC output current with Power assist (AC Out 2)	50A		
External AC current sensor (optional)	100A		

MultiPlus-II 230V AU	48/8000/110-100	48/10000/140-100	48/15000/200-100
Programmable relay (6)	Yes		
Protection (2)	a-g		
VE.Bus communication port	Yes		
General-purpose communication port	Yes, 2x		
Remote on/off terminal	Yes		
Operating temperature range	-20 to +65°C (fan-assisted cooling)		
Rated short-time withstand current (I _{cw})	6kA		
Humidity (non-condensing)	max 95%		
Environmental category	Indoor conditional		
Pollution degree	2		
Maximum altitude	2000m		
Country of manufacture	India		
ENCLOSURE			
Material and colour	Steel, blue RAL 5012		
Protection category	IP21		
Battery connection	M8 bolts		
AC connection	Screw terminals for wire up to 13mm ² (6 AWG)		
Weight	42 kg	49 kg	80 kg
Dimensions hwxwd (mm)	642 x 363 x 206	677 x 363 x 206	810 x 405 x 217
STANDARDS			
Safety	EN-IEC 60335-1, EN-IEC 60335-2-29, EN-IEC 62109-1, EN-IEC 62109-2 AS IEC 62477.1, AS/NZS 4777.2		
Emission, Immunity	EN 55014-1, EN 55014-2, EN-IEC 61000-3-2, EN-IEC 61000-3-3 IEC 61000-6-1, IEC 61000-6-2, IEC 61000-6-3		
<p>1) Can be adjusted to 60Hz</p> <p>2) Protection key:</p> <p>a) output short circuit</p> <p>b) overload</p> <p>c) battery voltage too high</p> <p>d) battery voltage too low</p> <p>e) temperature too high</p> <p>f) 230Vac on inverter output</p> <p>g) input voltage ripple too high</p> <p>3) Non-linear load, crest factor 3:1</p> <p>4) Up to 25°C ambient</p> <p>5) Other chemistries are possible as well, provided the charger is configured to confirm the battery manufacturer's specifications.</p> <p>6) A programmable relay can be set for a general alarm, DC under voltage, or a genset start/stop function. AC rating: 230V / 4A, DC rating: 4A up to 35VDC and 1A up to 60VDC</p>			

11. Appendix

11.1. Connection overview

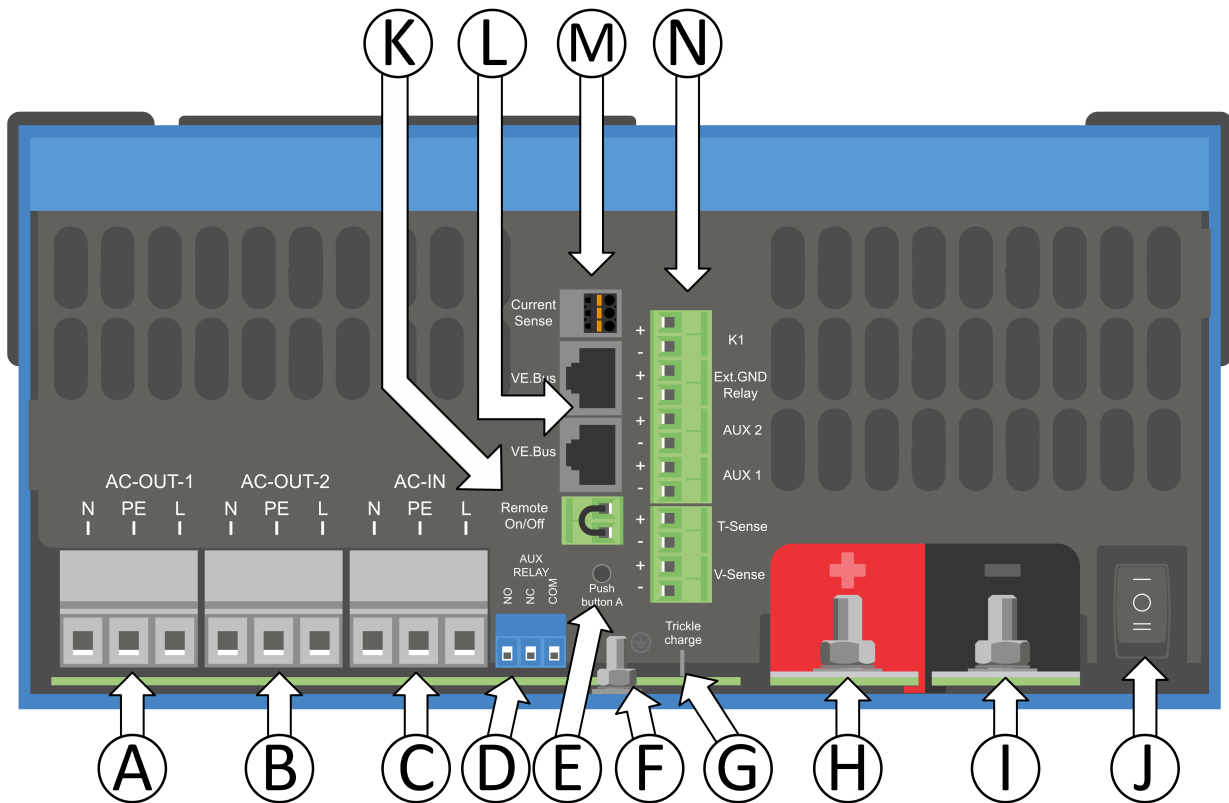

A	Load connection AC out1. Left to right: N (neutral), PE (earth/ground), L (phase)
B	Load connection AC out2. Left to right: N (neutral), PE (earth/ground), L (phase)
C	AC input. Left to right: N (neutral), PE (earth/ground), L (phase)
D	Alarm contact. Left to right: NO, NC, COM.
E	Push button A – To perform a startup without assistants.
F	Primary ground connection M6 (PE).
G	Trickle charge terminal (this feature is not available on these models)
H	M8 battery positive connection.
I	M8 battery minus connection.
J	switch: 1=On, 0=Off, =charger only
K	Connector for remote switch: Short to switch "on".
L	2x RJ45 VE-BUS connector for remote control and/or parallel / three-phase operation
M	External current sensor  To connect the current sensor, remove the wire bridge between the INT and COM terminals, connect the red sensor wire to the EXT terminal and connect the white sensor wire to the COM terminal.

N	<p>Terminal for (top to bottom):</p> <ol style="list-style-type: none">1. 12V 100mA2. Programmable contact K1 open collector 70V 100mA3. External ground relay +4. External ground relay –5. Aux input 1 +6. Aux input 1 –7. Aux input 2 +8. Aux input 2 –9. Temperature sense +10. Temperature sense –11. Battery voltage sense +12. Battery voltage sense -
---	--

11.2. Grid connection

This diagram applies when the system is used in a grid connected system.

Install a neutral link between the AC-In neutral and the AC-Out neutral, as shown in the diagram below. Make the connections within the switchboards.



The following grid code should be selected in VE.Configure:

Australia X: AS/NZS 4777.2:2020+A1+A2 stand alone app. M (with N-bypass)

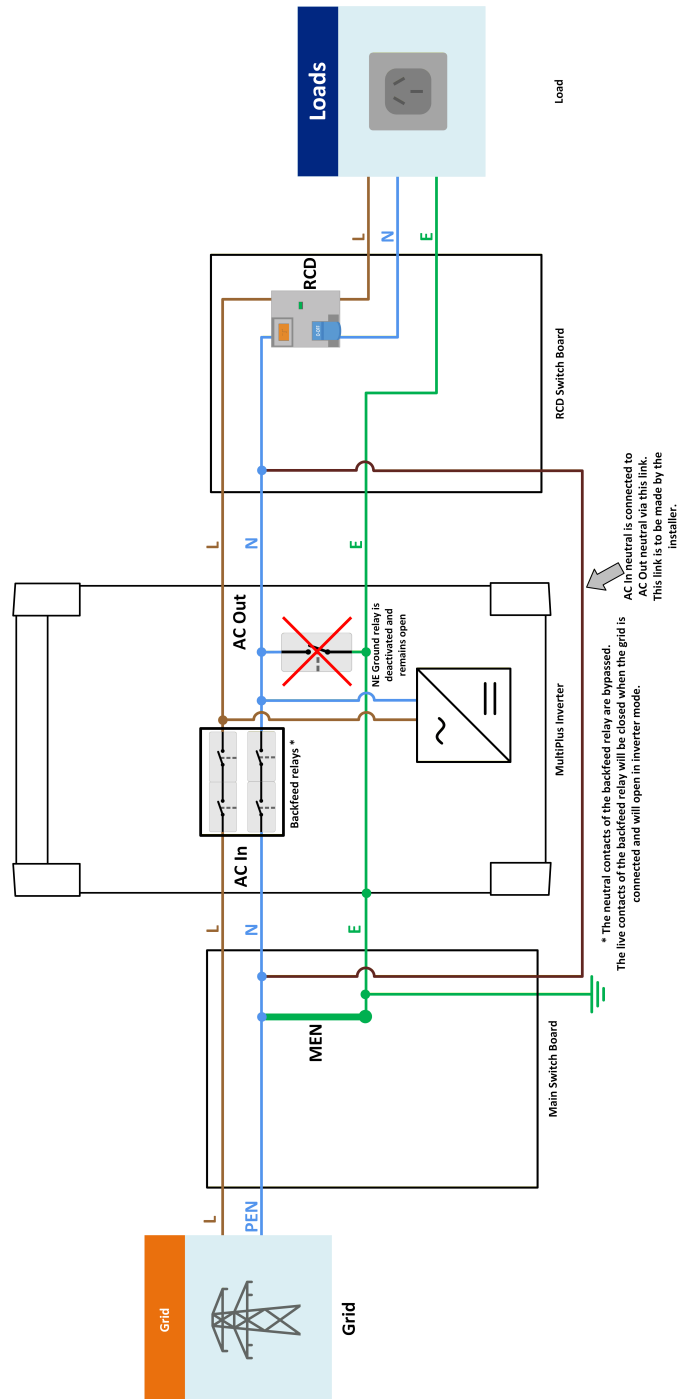

11.3. Generator connection

This diagram applies when the system is used with a generator connected to the AC input.

With this configuration, the inverter's internal ground relay is not used and remains open. The installation must therefore have a permanent MEN connection located at the Main Switchboard (MSB). This provides the required neutral-to-earth reference and ensures correct RCD operation.

Install a neutral link between the AC-In neutral and the AC-Out neutral, as shown in the diagram below. Make the connections within the switchboards.

The following grid code should be selected in VE.Configure:
Australia X: AS/NZS 4777.2:2020+A1+A2 stand alone app. M (with N-bypass)

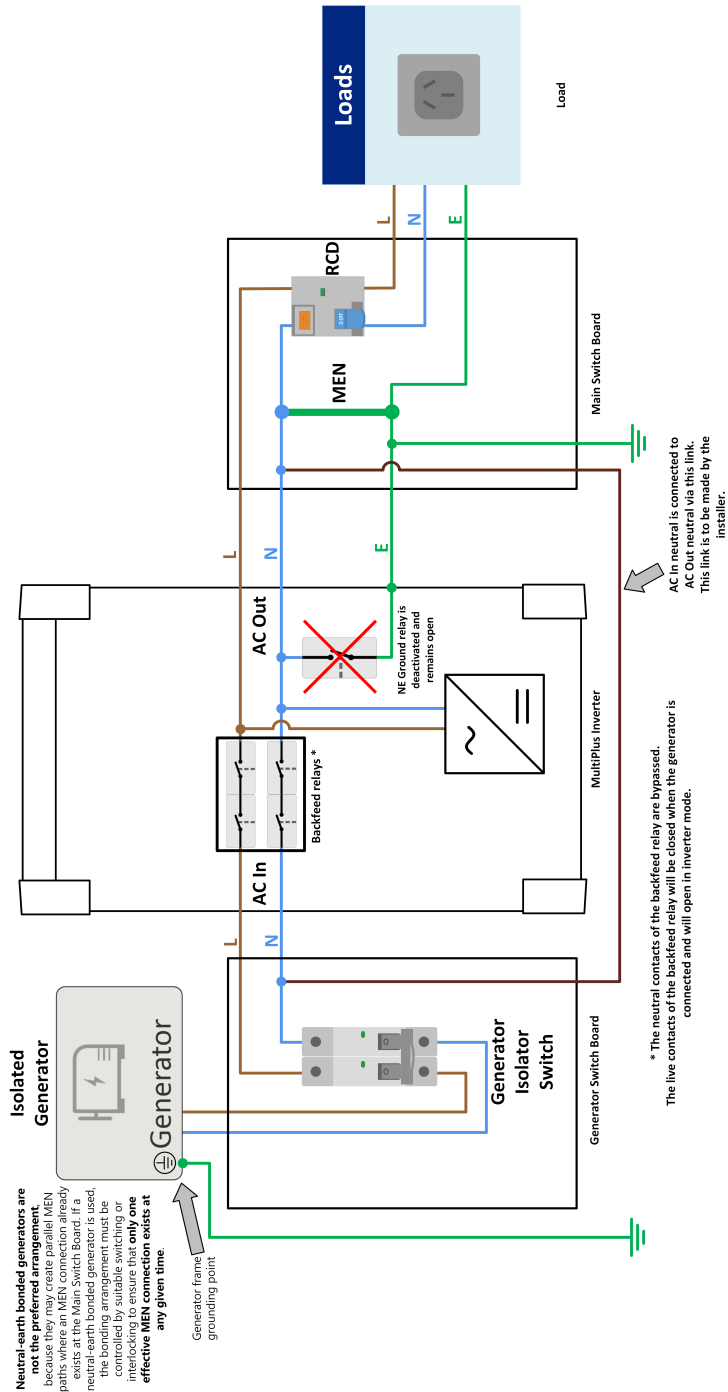

11.4. Stand alone wiring diagram

This diagram applies when the system is used as a stand-alone system.



The following grid code should be selected in VE.Configure:

Australia X: AS/NZS 4777.2:2020+A1+A2 stand alone app. M (with N-bypass)

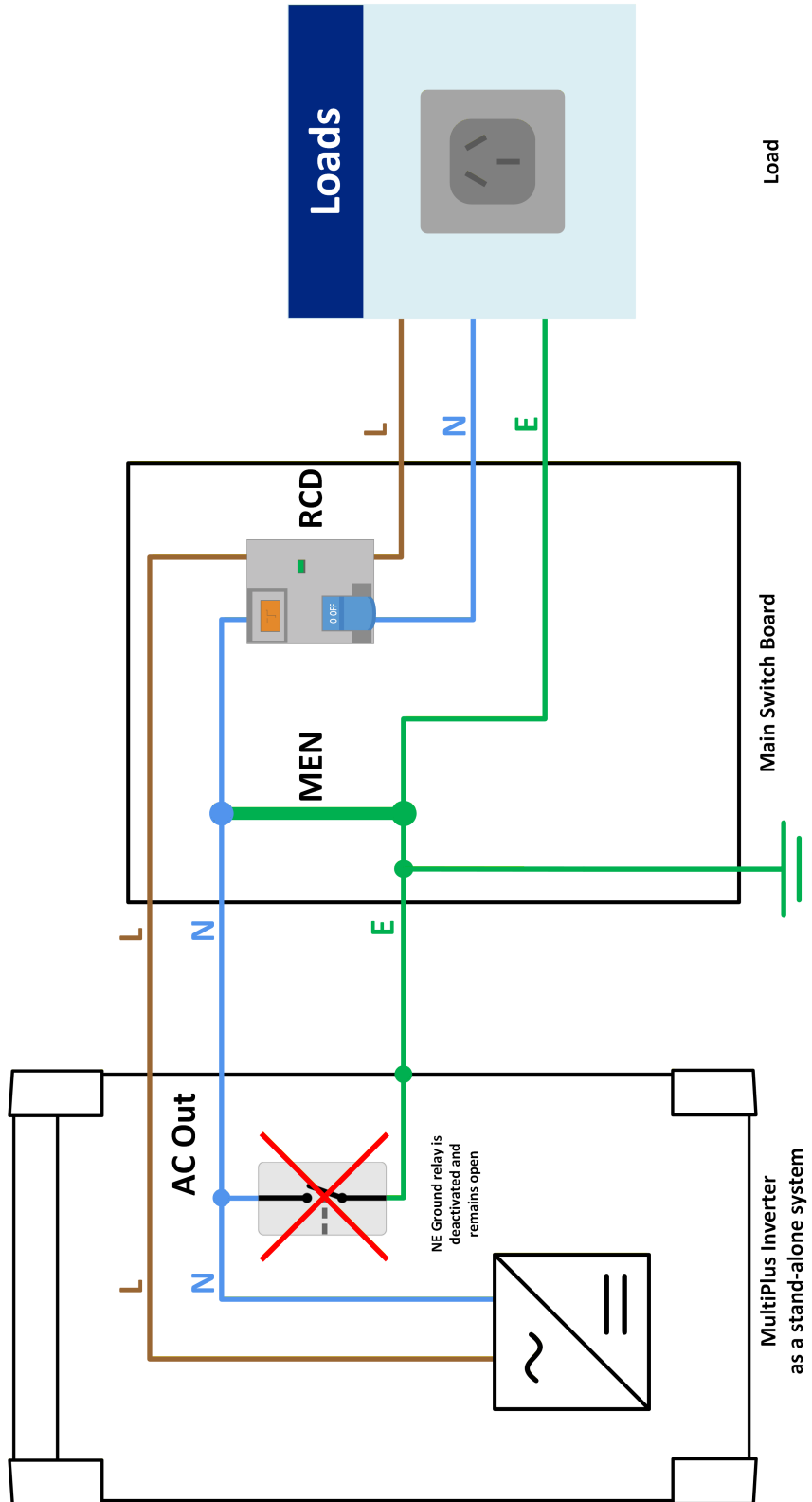

11.5. Block diagram

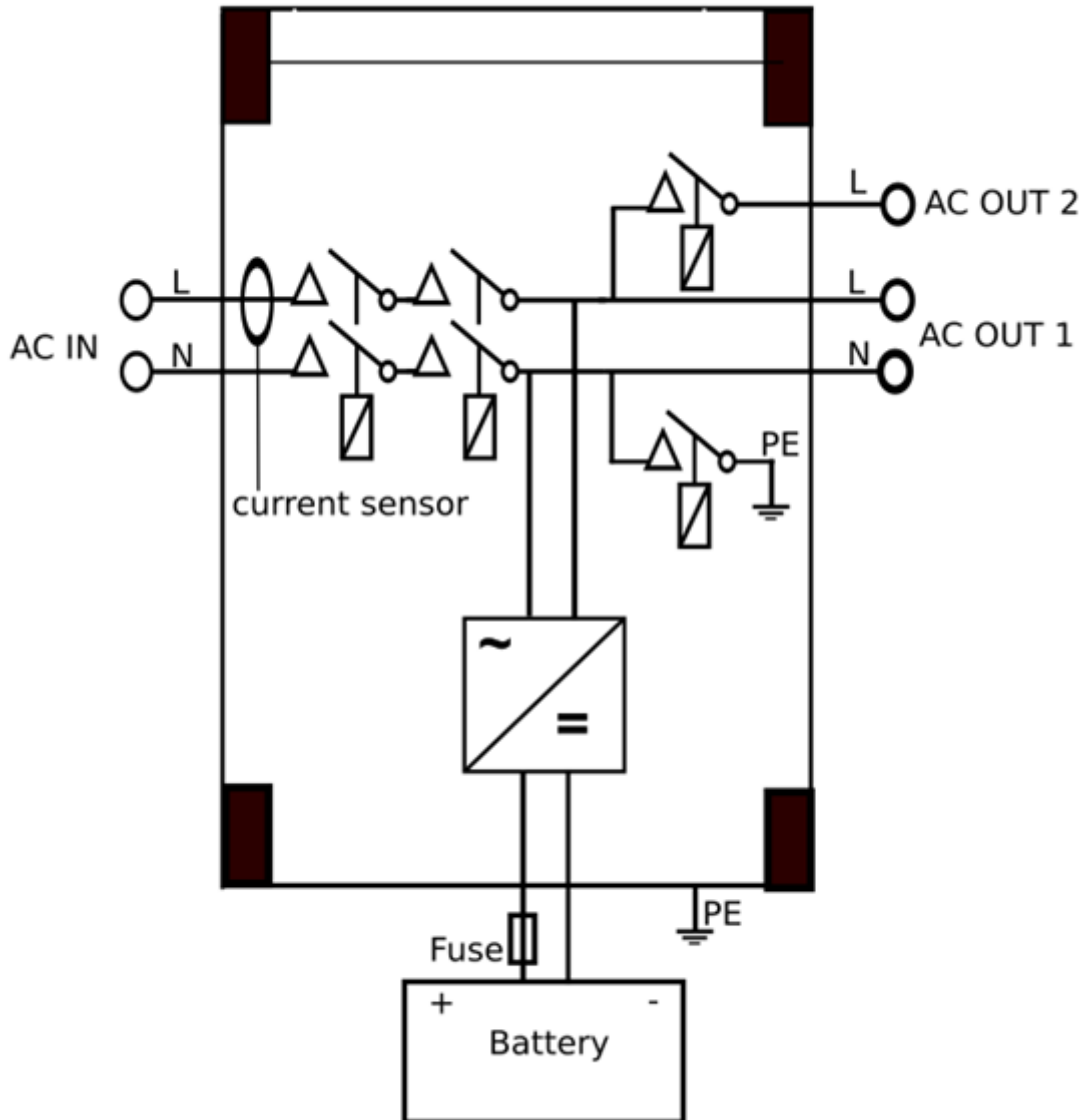

11.6. Parallel connection



The 8K and 10K units cannot be connected in parallel.

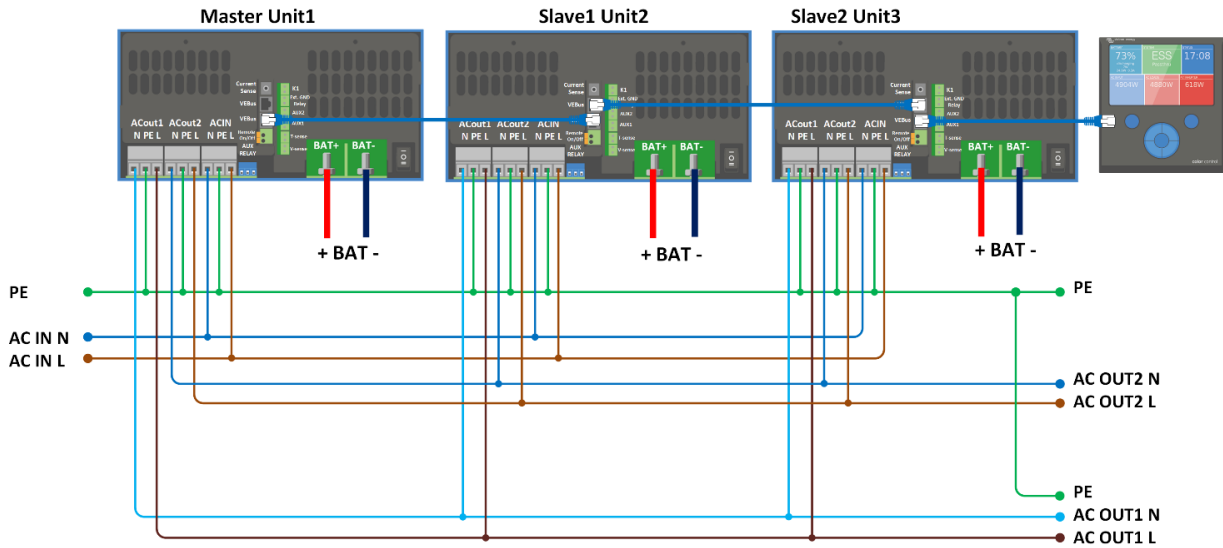

11.7. Three phase connection

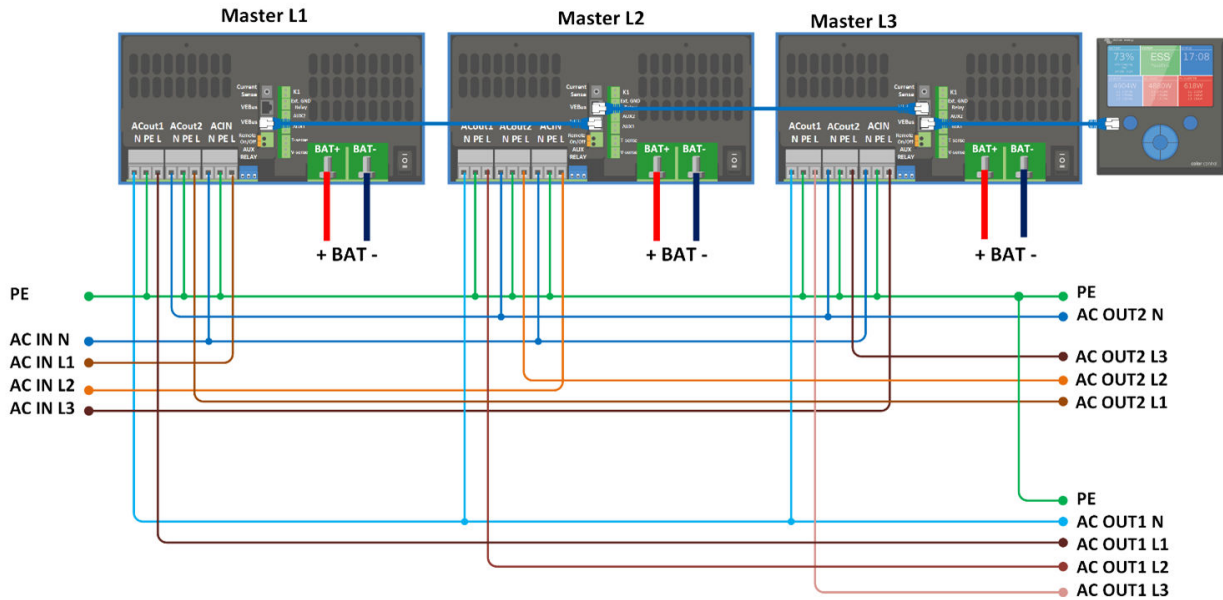

11.8. Charge algorithm

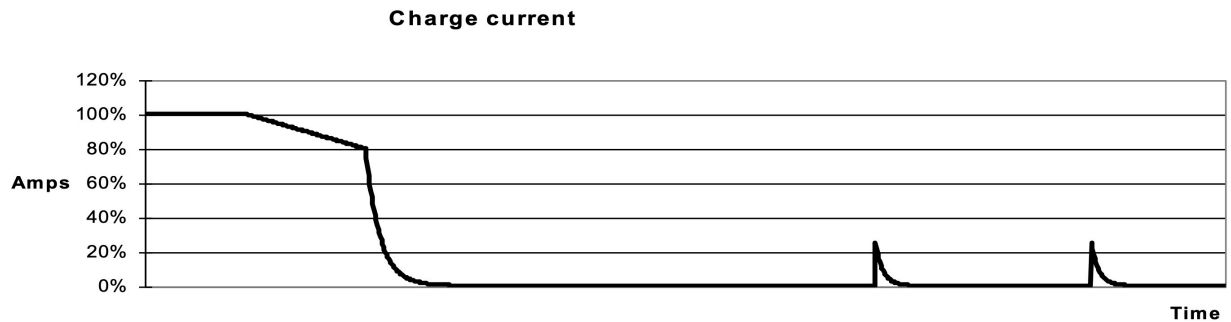

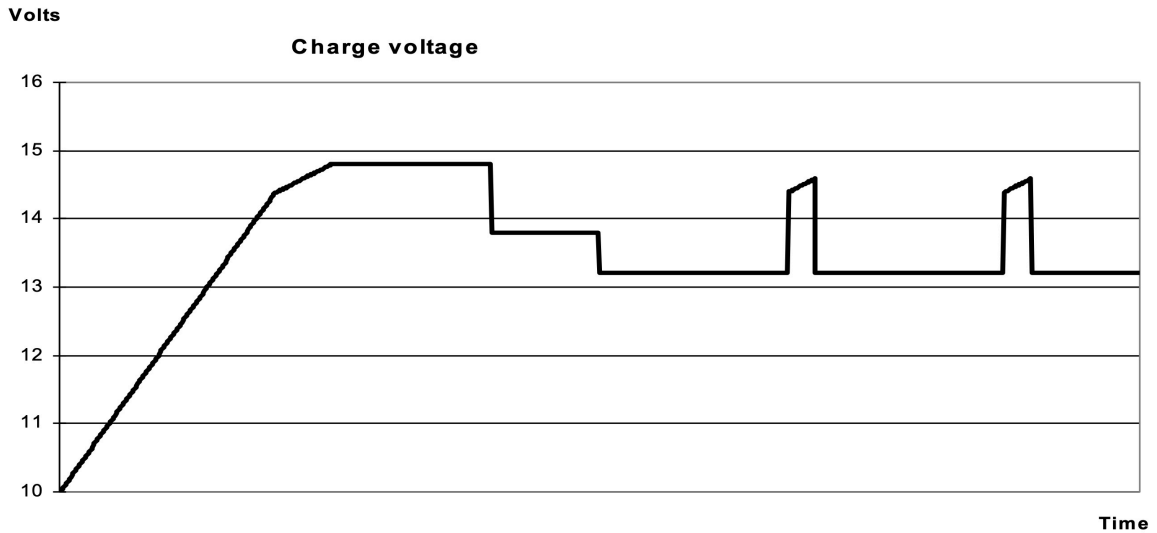

i The voltages in the above table are for a 12V battery bank. To arrive at 48V battery bank voltages, multiply the 12V voltages by a factor of four.

4-stage charging:

Bulk

Entered when charger is started. Constant current is applied until nominal battery voltage is reached, depending on temperature and input voltage, after which constant power is applied up to the point where excessive gassing starts. This is at 14.4 V for temperature compensated for lead acid batteries.

Battery Safe

The voltage applied to the battery is raised gradually until the set absorption voltage is reached. The Battery Safe Mode is part of the calculated absorption time.

Absorption

The absorption period is dependent on the bulk period. The maximum absorption time is the set Maximum Absorption time.

Float

Float voltage is applied to keep the battery fully charged.

Storage

After one day of float charge, the output voltage is reduced to the storage level. This is 1.2 V. This will limit water loss to a minimum when the battery is stored for the winter season. After an adjustable time (default = 7 days), the charger will enter Repeated Absorption mode for an adjustable time (default = one hour) to 'refresh' the battery.

11.9. Temperature compensation

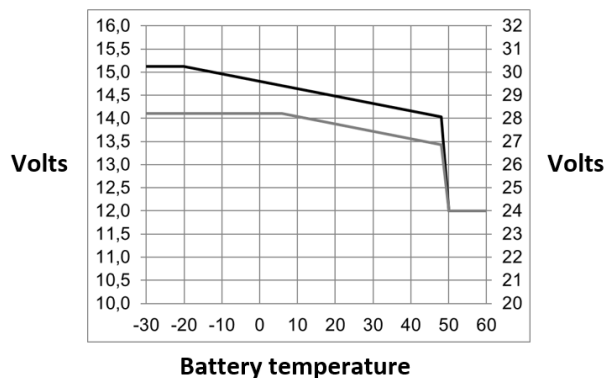

Default output voltages for Float and Absorption are at 25 °C for 12 or 24V battery bank.



To arrive at 48V battery bank voltages, multiply the 24V voltages by a factor of two.

Reduced Float voltage follows Float voltage and Raised Absorption voltage follows Absorption voltage. In adjust mode temperature compensation does not apply.

11.10. Dimensions

