



Isolation Transformer

4500W Auto 115/230V

Rev 00 - 01/2026

This manual is also available in HTML5.

Table of Contents

1. Safety Instructions	1
2. Features	2
2.1. Electrical safety	2
2.2. Galvanic corrosion prevention	2
2.3. Converting voltages	3
2.4. Automatic AC input voltage detection	3
2.5. Soft start	3
2.6. Internal wiring diagram	4
2.7. Safety when the vessel is out of the water	4
3. Installation	5
3.1. What's in the box	5
3.2. Connections overview	5
3.3. AC output configuration	5
3.4. Connecting AC input and AC output	6
3.5. Cable cross-section requirements	7
3.6. Wiring example	7
3.7. Linking input and output earth when the vessel is out of the water.	7
4. Operation	9
4.1. Automatic input voltage detection	9
4.2. LED indications	9
4.3. Inrush current limiter	9
4.4. Temperature protection	9
5. Technical specifications	10
6. Dimensions Isolation Transformer 4500W	11

1. Safety Instructions



WARNING: Before installing, using, storing or transporting this product, read and save the safety instructions below.

General:



- Review the related documentation of this product to familiarise yourself with safety markings and instructions before operating the equipment. This product has been designed and tested in accordance with international standards. Only use the equipment for the intended purpose of application and in accordance with the specifications as stated in the Technical specification chapter.
- **WARNING: RISK OF ELECTRIC SHOCK.**
- Do not open the enclosure if the product is still connected to an electrical power source.
- Do not remove the front panel or operate the product without all panels fitted. Refer all servicing to qualified personnel.
- Caution: never carry heavy loads without assistance.
- Do not expose the product to water, mist, snow, spray, or dust.
- Do not use the product in locations where there is a risk of gas or dust explosions. This product is not ignition protected.

Installation:



- Always refer to the installation section in the manual before applying power to the equipment.
- Connections, cable sizes and safety features must be according to the locally applicable regulations.
- This is a safety class I product (provided with a protective earthing terminal). An uninterruptible safety earth ground must be provided at the AC-in and AC-out terminals. An additional grounding point is located at the outside of the product. Whenever it is likely that the grounding protection has been impaired, the product must be made inoperative and secured against any unintended operation; refer to qualified service personnel.
- Make sure that circuit breakers are provided in the connecting wires. Never replace a safety component with a different type. Consult the manual to determine the correct component.
- Before applying power, verify that the available power source matches the configuration settings of the product as described in the manual.
- Ensure that the environmental conditions are suitable for the operation of the equipment. Never operate the product in the rain or a dusty environment. Allow at least 10cm of free space around the product for ventilation, and ensure that ventilation fans are not blocked. Install in a well-ventilated and heat-resistant environment. Avoid the presence of, e.g. chemicals, synthetic components, curtains or other textiles in the immediate vicinity of the product.
- Be sure that the demanded power does not exceed the product's power rating.

Transport and storage:



- When storing or transporting the product, make sure that all mains power leads are disconnected.
- No liability can be accepted for any transport damage when equipment is shipped in non-original packaging.
- Store the product in a dry location. Storage temperature must be between -20°C and 60°C.

2. Features

The isolation transformer eliminates any electrical continuity between AC shore power and the vessel. It is essential for safety and eliminates the need for galvanic isolators and polarity alarms.

2.1. Electrical safety

Electrical safety is taken for granted in the case of a standard on-shore installation. A circuit breaker, or a GFCI (Ground Fault Circuit Interrupter) will trip in case of a short circuit or a current leakage to ground.

Connecting the ground wire of the shore-side supply to a vessel's metal parts will result in galvanic corrosion.

Bringing only the live and neutral wire onboard results in an unsafe situation because GFCIs will not work, nor will a breaker trip in case of a short circuit to a metal part on the vessel.

2.2. Galvanic corrosion prevention

Galvanic corrosion occurs when two dissimilar metals in electrical contact are simultaneously exposed to an electrically conducting fluid. Seawater and, to a lesser extent, freshwater are such fluids. In general, the more active alloy of the couple corrodes preferentially, while the less active (more noble) material is cathodically protected. The rate of galvanic corrosion is a function of several variables, including area ratios, the conductivity of the fluid, temperature, the nature of the materials, etc.

It is a misunderstanding that galvanic corrosion occurs only in metal and aluminium hulls. In fact, it can occur on any vessel as soon as a metallic part (the shaft and propeller) is in contact with water. Galvanic corrosion will quickly dissolve your sacrificial anodes and attack the shaft, propeller and other metal parts in contact with water when the vessel is connected to the shore-side supply. It might therefore be tempting not to connect the ground conductor: this is, however, extremely dangerous because a GFCI will not work, nor will a circuit breaker trip in case of a short circuit to a metal part on the vessel.

The best solution to avoid galvanic corrosion and, at the same time, prevent any unsafe situation is to install an isolation transformer to connect to the shore-side supply. The isolation transformer eliminates any electrical continuity between shore power and the vessel. The shore power is fed to the transformer's primary side, and the vessel is connected to the secondary. The isolation transformer completely isolates the vessel from the shore ground. By connecting all metal parts to the neutral output on the secondary side of the transformer, a GFCI or a breaker will trip in case of a short circuit.

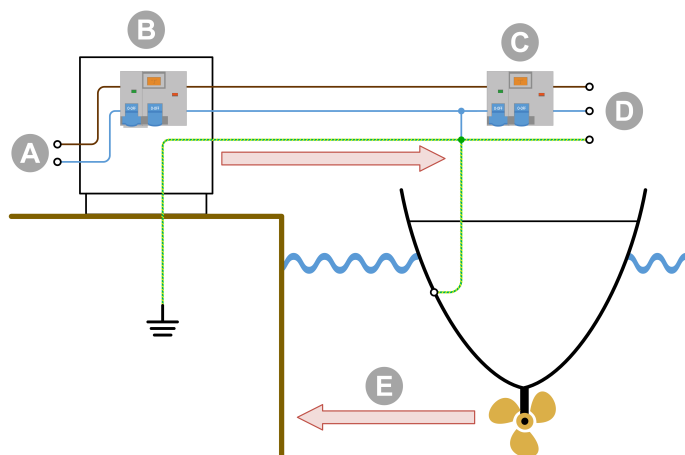

ID	Description
A	Shore AC supply
B	Shore AC distribution
C	GFCI (ground fault circuit interrupter)
D	Vessel AC supply
E	Galvanic corrosion

The shore ground connected to immersed metals of the vessel causes galvanic corrosion.

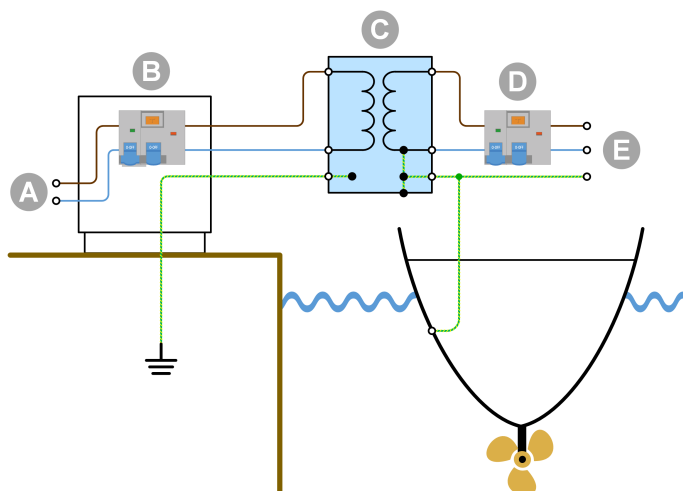

ID	Description
A	Shore AC supply
B	Shore AC distribution
C	Isolation transformer
D	GFCI (ground fault circuit interrupter)
E	Vessel AC supply

The shore ground is isolated from the vessel ground, and galvanic corrosion originating from the shore connection is blocked.

2.3. Converting voltages

The isolation transformer converts the input voltage with a 1:1.05 ratio. The 1:1.05 transformer ratio boosts the output voltage of the isolation transformer by 5%. This is to compensate for shore power voltage drops that are a common occurrence in marinas.

The isolation transformer can be used in 115V or 230V systems and also be used to convert 230V to 120V and 115V to 240V. Depending on the isolation transformer configuration:

- A 230V input becomes 240V.
- A 230V input becomes 120V.
- A 115V input becomes 240V.
- A 115V input becomes 120V.

The isolation transformer can be used in 50Hz or 60Hz systems. However, the isolation transformer cannot convert frequencies from 50Hz to 60Hz or vice versa.

2.4. Automatic AC input voltage detection

The isolation transformer will automatically detect the incoming voltage and will switch to a 115 or 230V AC input configuration, depending on the input voltage:

- If the incoming voltage is between 88 and 130V, the transformer switches to 115V input mode.
- If the incoming voltage is between 185 and 250V, the transformer switches to 230V input mode.

2.5. Soft start

Soft start is a standard feature of a Victron Energy isolation transformer. It will prevent the shore power circuit breaker from tripping due to the transformer inrush current.

2.6. Internal wiring diagram

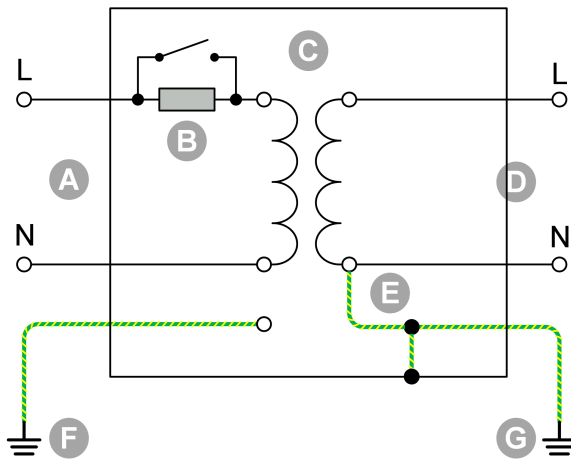

Internal wiring diagram of the isolation transformer.

ID	Description
A	Shore AC connection
B	Soft start
C	Transformer
D	Vessel AC connection
E	Neutral - Earth link (removable)
F	Shore Earth
G	Vessel Earth

2.7. Safety when the vessel is out of the water

It is recommended, for optimal safety, to connect the shore earth to the vessel's earth when the vessel is out of the water, in winter or for maintenance. The isolation transformer has a facility for this.

3. Installation

3.1. What's in the box

The isolation transformer ships with the following items:

Description
1x hanging bracket, used for mounting the isolation transformer inside a vessel.
1x isolation transformer.
1x long yellow/green jumper wire with female 6.35 mm spade connectors, used to connect AC input earth (PE) to AC output earth (PE) when the vessel is out of the water for maintenance or winter storage.
1x long yellow/green wire with eye terminals, used for case grounding.
1x short yellow/green jumper wire with female 6.35 mm spade connectors, used to make AC output neutral (N) to earth (PE) link.
4x short black jumper wires with 6.35 mm female spade connectors, used for AC configuration.
7x mounting screws

3.2. Connections overview



ID	Description
1	AC input screw terminals (shore power): Phase (Lin) neutral (Nin) and earth (PEin).
2	Male spade terminals to establish an AC output neutral to earth connection link for a correct operation of an AC output GFCI: Connect J33 to J21.
3	Male spade terminals to configure the AC output voltage: For 115V, connect J29 to J32 and connect J31 to J25. For 230V, connect J31 to J32.
4	AC output screw terminal (AC loads or AC installation): Phase (Lout) neutral (Nout) and earth (PEout).
5	Male spade terminals to bridge AC input earth to AC output earth when the vessel is out of the water: Connect J34A to J34.

3.3. AC output configuration

The AC output needs to be configured for 115 or 230V use. This is done by connecting male spade terminals using the black jumper wires (included). These terminals are located above the AC output connector.

AC output voltage	Connect jumper cable between	Connections
115V	J29 and J32 J31 and J25	
230V	J31 and J32	

3.4. Connecting AC input and AC output



Shock hazard. Do not work on the isolation transformer or the electrical system if still connected to an electrical power source.

Connection sequence:

1. Pass the AC cables through the cable glands at the bottom of the cabinet in the following way:
 - a. Pass the AC input (shore power) cable through the left side cable gland.
 - b. Pass the AC output (AC loads) cable through the right side cable gland.
2. Connect the AC input cable to the INPUT terminal block in the following way:
 - a. Connect the earth wire to the PE terminal.
 - b. Connect the neutral wire to the N terminal.
 - c. Connect the phase wire to the L terminal.
3. Connect the AC output cable to the OUTPUT terminal block in the following way:
 - a. Connect the earth wire to the PE terminal.
 - b. Connect the neutral wire to the N terminal.
 - c. Connect the phase wire to the L terminal.
4. Connect the enclosure to the ground (=all the metal parts in the vessel) in the following way:
 - a. Connect the M6 bolt underneath the enclosure to the vessel ground. See the below drawing for the location of the chassis earth bolt.

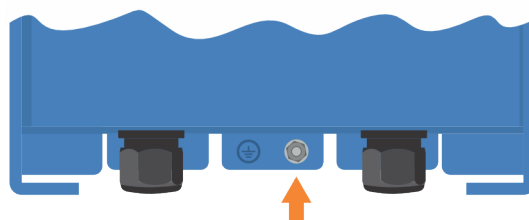

Location of the chassis earth bolt.

3.5. Cable cross-section requirements

Use the following minimal cable cross-sections:

Isolation transformer power rating	Voltage	Metric	AWG
4500 W	115 V	6 mm ²	AWG 10
4500 W	230 V	4 mm ²	AWG 11

3.6. Wiring example

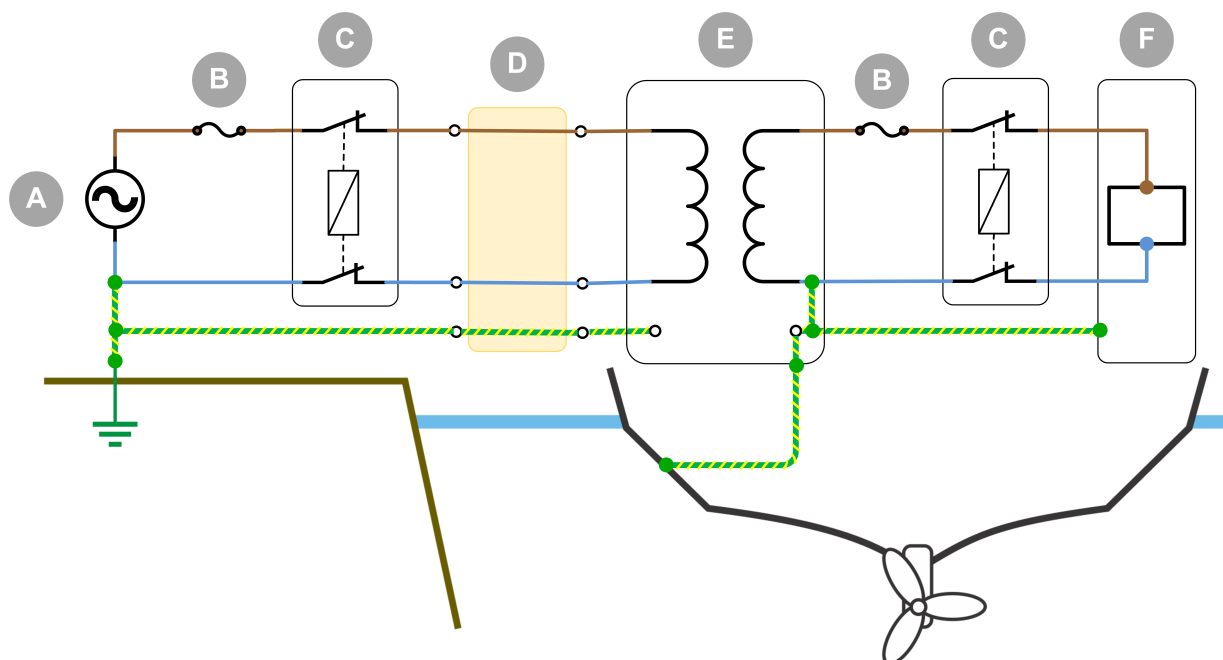

Wiring example isolation transformer installed on a vessel connected to shore power.

ID	Description
A	Shore power.
B	Circuit breaker.
C	GFCI (Ground Fault Circuit Interrupter).
D	Shore cable.
E	Isolation transformer.
F	AC loads.

3.7. Linking input and output earth when the vessel is out of the water.

For safety reasons, when the vessel is out of the water (on land) during winter or for maintenance, the vessel's earth (PE) conductor must be connected directly to the shore power earth (PE) conductor.

This can be achieved inside the isolation transformer by connecting the yellow/green jumper wire (included) between male spade terminals J34A and J34, as indicated below.

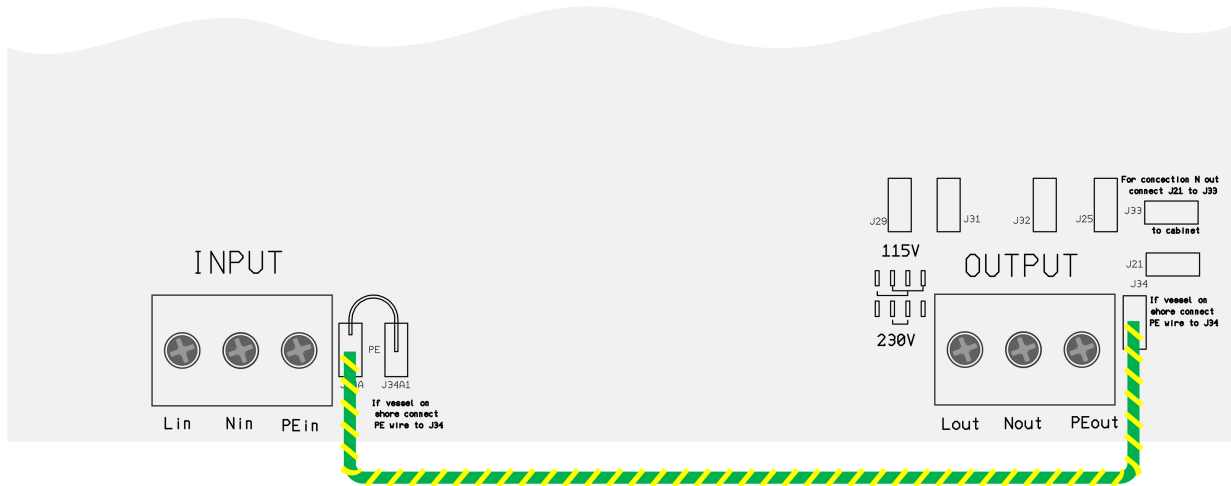

AC input earth is connected to AC output earth when the vessel is out of the water (on land) during winter or for maintenance.

4. Operation



Check the input and output voltage configuration before operating the isolation transformer.

4.1. Automatic input voltage detection

The isolation transformer automatically detects the incoming voltage and will set its input voltage mode according to the below table.

Input voltage range	Green "on" LED	Yellow "115V" LED	Yellow "230V" LED	Behaviour
0 - 87V	On	Off	Off	Both the input and output are switched off.
88V - 130V	On	On	Off	Operating in 115V input mode.
130V - 185V	On	Off	Off	Both the input and output are switched off.
185V - 250V	On	Off	On	Operating in 230V input mode.

4.2. LED indications

The isolation transformer has the following LED indications:

LED	Colour	Description
on	Green	Lights when the isolation transformer is operational.
230V	Yellow	Lights when the isolation transformer is operating in 230Vac input mode.
115V	Yellow	Lights when the isolation transformer is operating in 115Vac input mode.
Temperature	Red	Lights when the fan is on.

4.3. Inrush current limiter

The inrush current limiter prevents upstream circuit breakers from tripping when switching on the isolation transformer.

4.4. Temperature protection

The isolation transformer is fan cooled. The fan speed is temperature-controlled. Its speed (rpm) will increase if the temperature increases.

The isolation transformer is protected against overtemperature and will switch off in case of overheating.

5. Technical specifications

Isolation Transformer	4500W auto 115/230V
AC input voltage *	115 or 230V, automatic detection
AC output voltage *	120 or 240V
Frequency	50/60Hz
Output current rating	38A (115V) 19A (230V)
Soft start	Yes
Operating temperature range	-20°C to 40°C
Humidity	Max 95%, non-condensing
Transformer type	Toroidal (low noise, low weight), 1:1.05 ratio
Enclosure	Aluminium (blue RAL 5012)
Protection category	IP21
Safety	EN 60076
Weight	21.8 kg
Dimensions (h x w x d), mm	362 x 258 x 221

*) The isolation transformer can be used as:

- 115V to 120V isolation transformer
- 230V to 240V isolation transformer
- 115V to 240V isolation transformer
- 230V to 120V isolation transformer

6. Dimensions Isolation Transformer 4500W

