

# Phoenix Inverters 3 kVA

(120V/60Hz)

[www.victronenergy.com](http://www.victronenergy.com)



**Phoenix Inverter  
24/3000**

### SinusMax - Superior engineering

Developed for professional duty, the Phoenix range of inverters is suitable for the widest range of applications. The design criteria have been to produce a true sine wave inverter with optimised efficiency but without compromise in performance. Employing hybrid HF technology, the result is a top quality product with compact dimensions, light in weight and capable of supplying power, problem free, to any load.

### Extra start-up power

A unique feature of the SinusMax technology is very high start-up power. Conventional high frequency technology does not offer such extreme performance. Phoenix inverters, however, are well suited to power up difficult loads such as refrigeration compressors, electric motors and similar appliances.

### Virtually unlimited power thanks to parallel 3-phase and split phase operation capability

Up to 6 units inverters can operate in parallel to achieve higher power output. Six 24/3000 units, for example, will provide 15 kW / 18 kVA output power. Operation in 3-phase or split phase configuration is also possible.

### To transfer the load to another AC source: the automatic transfer switch

If an automatic transfer switch is required we recommend using the MultiPlus inverter/charger instead. The switch is included in these products and the charger function of the MultiPlus can be disabled. Computers and other electronic equipment will continue to operate without disruption because the MultiPlus features a very short switchover time (less than 20 milliseconds).

### Computer interface

All models have a RS-485 port. All you need to connect to your PC is our MK2 interface (see under accessories). This interface takes care of galvanic isolation between the inverter and the computer, and converts from RS-485 to RS-232. A RS-232 to USB conversion cable is also available. Together with our VEConfigure software, which can be downloaded free of charge from our website, all parameters of the inverters can be customised. This includes output voltage and frequency, over and under voltage settings and programming the relay. This relay can for example be used to signal several alarm conditions, or to start a generator. The inverters can also be connected to VENet, the new power control network of Victron Energy, or to other computerised monitoring and control systems.

### New applications of high power inverters

The possibilities of paralleled high power inverters are truly amazing. For ideas, examples and battery capacity calculations please refer to our book 'Energy Unlimited' (available free of charge from Victron Energy and downloadable from [www.victronenergy.com](http://www.victronenergy.com)).

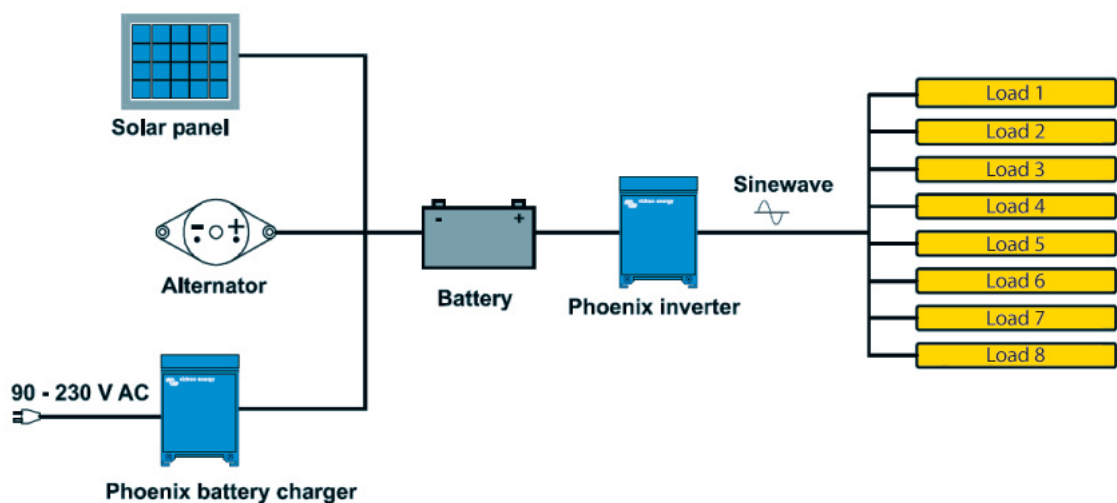

Phoenix Inverter	12/3000	24/3000
Parallel,3-phase and split-phase operation	Yes	
<b>INVERTER</b>		
Input voltage range (V DC)	9,5 – 17V	19 – 33V
Output	Output voltage: 120 VAC ±2% Frequency: 60 Hz ± 0,1% (1)	
Cont. output power at 25°C / 77°F (VA) (2)	3000	3000
Cont. output power at 25°C / 77°F (W)	2400	2400
Cont. output power at 40°C / 104°F (W)	2200	2200
Cont. output power at 65°C / 150°F (W)	1700	1700
Peak power (W)	6000	6000
Max. efficiency (%)	93	94
Zero load power (W)	20	20
Zero load power in AES mode (W)	15	15
Zero load power in Search mode (W)	8	10
<b>GENERAL</b>		
Programmable relay (3)	Yes	
Protection (4)	a - g	
VE.Bus communication port	For parallel and three phase operation, remote monitoring and system integration	
Remote on-off	Yes	
Common Characteristics	Operating temperature range: -40 to +65°C (-40 - 150°F) Humidity (non-condensing): max 95%	
<b>ENCLOSURE</b>		
Common Characteristics	Material & Colour: aluminium (blue RAL 5012) Protection category: IP 21	
Battery-connection	2+2 M8 bolts	
230 V AC-connection	Screw terminals	
Weight	18 kg 38 lbs	
Dimensions (hxwx d)	362x258x218 mm 14.3x10.2x8.6 inch	
<b>STANDARDS</b>		
Safety	EN 60335-1	
Emission Immunity	EN 55014-1 / EN 55014-2	
1) Can be adjusted to 60 Hz and to 240 V 2) Non-linear load, crest factor 3:1 3) Programmable relay that can a.o. be set for general alarm, DC under voltage or genset start/stop function. AC rating: 230 V/4A DC rating: 4 A up to 35 VDC, 1 A up to 60 VDC	4) Protection key: a) output short circuit b) overload c) battery voltage too high d) battery voltage too low e) temperature too high f) 230 V AC on inverter output g) input voltage ripple too high	



### Phoenix Inverter Control

This panel can also be used on a MultiPlus inverter/charger when an automatic transfer switch but no charger function is desired. The brightness of the LEDs is automatically reduced during night time.

### Computer controlled operation and monitoring

Several interfaces are available:



#### Color Control GX

Provides monitor and control. Locally, and also remotely on the [VRM Portal](#).



#### MK3-USB VE.Bus to USB interface

Connects to a USB port ([see 'A guide to VEConfigure'](#))



#### VE.Bus to NMEA 2000 interface

Connects the device to a NMEA2000 marine electronics network. See the [NMEA2000 & MFD integration guide](#)



### BMV Battery Monitor

The BMV Battery Monitor features an advanced microprocessor control system combined with high resolution measuring systems for battery voltage and charge / discharge current. Besides this, the software includes complex calculation algorithms, like Peukert's formula, to exactly determine the state of charge of the battery. The BMV selectively displays battery voltage, current, consumed Ah or time to go. The monitor also stores a host of data regarding performance and use of the battery.

Several models available (see battery monitor documentation).