

Multi RS 48/6000/100 Inverter/Charger

www.victronenergy.com

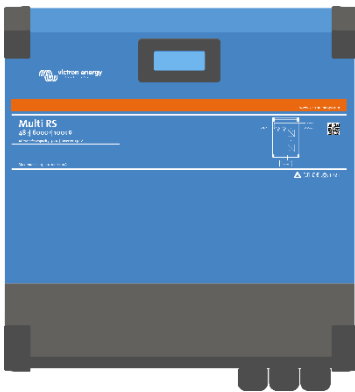

Multi RS 48/6000/100

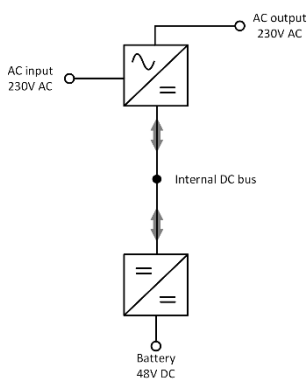

Multi RS block diagram

Operating modes

Backup mode – Switches to backup mode during a grid outage.

Off-grid mode – Operates without grid connection.

Generator mode – Controls the generator to minimize run-hours. Supplies additional power from the battery when demand exceeds the capacity of the generator.

PowerControl and PowerAssist - Boosting the capacity of the grid or a generator

A maximum grid or generator current can be set. The Multi RS will then take account of other AC loads and use whatever is extra for battery charging, thus preventing the generator or grid from being overloaded (PowerControl function).

PowerAssist takes the principle of PowerControl to a further dimension. Where peak power is so often required only for a limited period, the Multi RS will compensate insufficient generator or grid power with power from the battery. When the load reduces, the spare power is used to recharge the battery.

Display, Bluetooth and VictronConnect app

The display reads battery, inverter and solar parameters. The same parameters can be accessed with a smartphone or other Bluetooth enabled device, using the VictronConnect app.

Optional external PV capacity, both AC-coupled and DC-coupled

Optional solar chargers can be added to the system.

Alternatively, the PV capacity can be added by installing PV Inverters to the AC output, of which the output power will be automatically controlled by the integrated frequency shift power control.

Communication ports

VE.Can connection to a GX device for system monitoring, energy meter ⁽¹⁰⁾, data logging, and remote firmware updates.

VE.Direct connection to a GlobalLink 520 for remote data monitoring.

I/O Connections

Programmable relay, temperature sensor and voltage sensor connections.

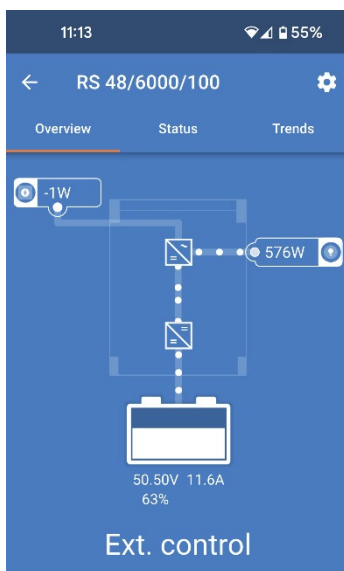

Configure and monitor with VictronConnect
A built in Bluetooth Smart connection allows for quick monitoring or settings adjustment of the Multi RS.

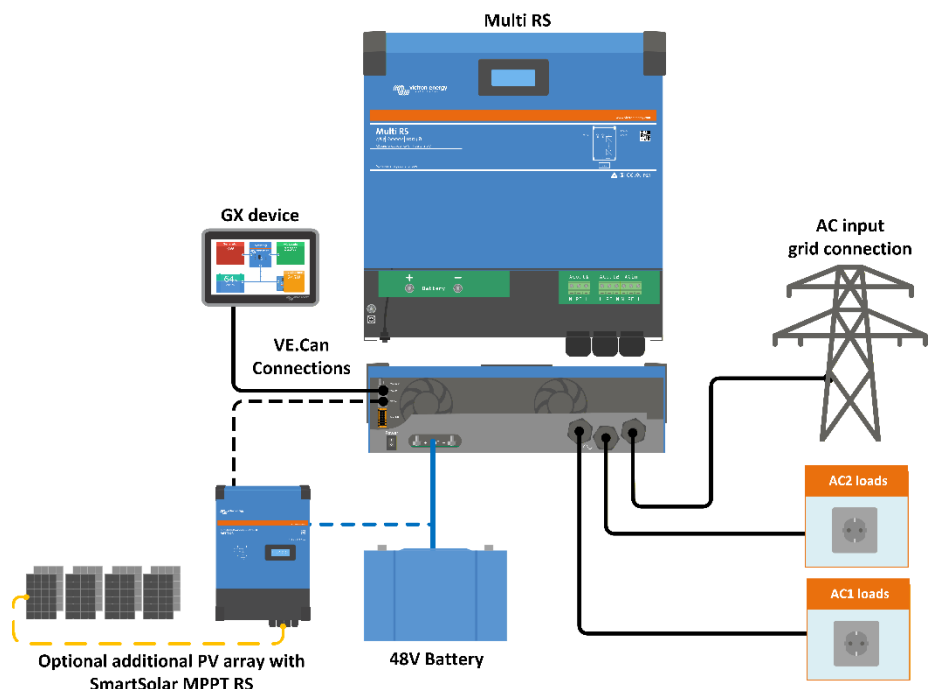

Multi RS 48/6000/100	
PowerControl & PowerAssist	Yes
Transfer switch	50 A
Maximum AC input and pass-through current	50 A
INVERTER	
DC Input voltage range ⁽¹⁾	38 – 62 V
AC Output ⁽²⁾	Output voltage: 230 VAC ± 2 % Frequency: 50 Hz ± 0,1 % Maximum continuous inverter current: 25 Aac
Continuous output power at 25 °C	Increases linearly from 4600 W at 46 VDC to 5200 W at 52 VDC
Continuous output power at 40 °C	4500 W
Continuous output power at 65 °C	3000 W
Peak power ⁽³⁾	9 kW for 3 seconds 7 kW for 4 minutes
Short-circuit output current	45 A
Max. AC output overcurrent protection	30 A
Efficiency	96,5 % at 1 kW load 94 % at 5 kW load
Zero load power consumption	20 W
Low Battery shutdown	37.2 V (adjustable)
Low battery restart	43.6 V (adjustable)
CHARGER	
AC Input	Nominal Voltage: 230 VAC, Input voltage range: 187-265 VAC Nominal frequency: 50 Hz, Input frequency: 45-65 Hz AC inrush current: NA
Programmable charge voltage range ⁽⁴⁾	36 – 60 V
Charge voltage 'absorption'	Default setting: 57.6 V (adjustable)
Charge voltage 'float'	Default setting: 55.2 V (adjustable)
Maximum charge current from AC ⁽⁵⁾	88 A @ 57.6 VDC
Battery temperature sensor	Included
Battery voltage sense	Yes
Icw and Ipk requirements	Icw: 500A @ 0.1s and Ipk: 2kA
GENERAL	
Auxiliary output (AC-out-2) ⁽⁶⁾	Yes
3-phase and parallel operation	3-phase support with one unit per phase. Parallel not supported.
Programmable relay ⁽⁷⁾	Yes
Protections ⁽⁸⁾	a - f
Data communications ports ⁽⁹⁾	VE.Direct, VE.Can & Bluetooth
Bluetooth frequency & power	2402 - 2480 MHz, 4 dBm
Programmable analog/digital input/output ports	Yes, 2x
Remote on-off	Yes
Operating temperature range	-40 to +65 °C (fan assisted cooling)
Maximum altitude	2000 m
Humidity (non-condensing)	max 95 %
Earthing system	TN and TT only
ENCLOSURE	
Material & Colour	steel, blue RAL 5012
Protection category	IP21 Protective Class: I
Battery-connection	M8 bolts
230 VAC-connection	Screw terminals 10 mm ² (6 AWG)
Weight	11.2 kg
Dimensions (hxxxd)	462 x 425 x 127 mm
STANDARDS	
Safety	EN-IEC 60335-1, EN-IEC 60335-2-29, EN-IEC 62109-1, EN-IEC 62109-2, IEC 62040, IEC 62477
Emission, Immunity	EN 55014-1, EN 55014-2, EN-IEC 61000-3-2, EN-IEC 61000-3-3, IEC 61000-6-1, IEC 61000-6-2, IEC 61000-6-3, Pollution Degree 2
Oversvoltage Category	Battery: OVC 1, AC in / AC out: OVC III
UPS Specification	Input: 230 VAC, 46 A, 50 Hz Output: 230 VAC, 26 A, 50 Hz, 6 kVA / 5 kW Protective device (input and output): Max 50 A circuit breaker
<p>1) Minimum start-up voltage is 41 VDC. Over-voltage disconnect: 65,5 V. 2) Can be adjusted to 240 VAC and 60 Hz 3) Peak power capacity and duration depends on start temperature of heatsink. Mentioned times are with cold unit. 4) The Charger set points (float & absorption) can be set to max 60 V. The output voltage at the charger terminals can be higher due to compensation for temperature & voltage drop over the battery cables. The maximum output current is reduced on a linear basis from full current at 60 V to 5 A at 62 V. The equalization voltage can be set to max 62 V, the equalization current percentage can be set to max 6 %. 5) The maximum charge current from AC sources depends on input voltage and battery current. At 230V input and 57.6V battery voltage, and 25C ambient, the maximum charge current is 88 A. See manual, limitations section, for further details. 6) AC-out-2 is connected directly to the AC input and intended for non-critical loads. The AC-out-2 load is taken into account by PowerControl & PowerAssist. 7) Programmable relay which can be set for general alarm, DC under voltage or genset start/stop function. DC rating: 4 A up to 35 VDC and 1 A up to 70 VDC 8) Protection key: a) output short circuit b) overload c) battery voltage too high d) battery voltage too low e) temperature too high f) 230 VAC on inverter output 9) Not currently compatible with VE.Smart Networks. Connection to a GX device (i.e. Cerbo GX) must be made via the VE.Can interface. The VE.Direct interface is for connection to the GlobalLink 520. 10) Connectivity to the Victron VM-3P75CT energy meter must be made via VE.Can or Ethernet. Avoid intermediate WiFi links between the energy meter and the GX device, as WiFi can introduce latency and reduce reliability.</p>	