

# MultiPlus Backup only 1600VA / 12 volt / 440Ah battery

A simple system for mains backup.

## Introduction

A simple system for mains backup. When mains power is available the loads are powered directly. If the mains is not available, the loads are powered with the energy from the batteries. When the mains is available again the power will be supplied directly from the mains and the batteries will be charged again.

## How long is the autonomy? (ie. how long can it run on batteries)

The run time on batteries depends on the power consumption. If the power consumption is high like during the day then time available will be short. During the night when power consumption is low, it will be the other way around.

Average load	Run time
100 W	INVULLEN!
800 W	INVULLEN!

Note that these times are calculated to discharge the battery to 50%, which is the recommended maximum for GEL and AGM batteries.

## Parts

- 1x - CMP121620000 - [MultiPlus Compact 12/1600/70-16 230V VE.Bus Inverter/Charger](#)
- 2x - BAT412201080 - [12V/220Ah AGM Deep Cycle Battery](#) (or another brand of battery, see below for advice)
- 2x - Battery link cables

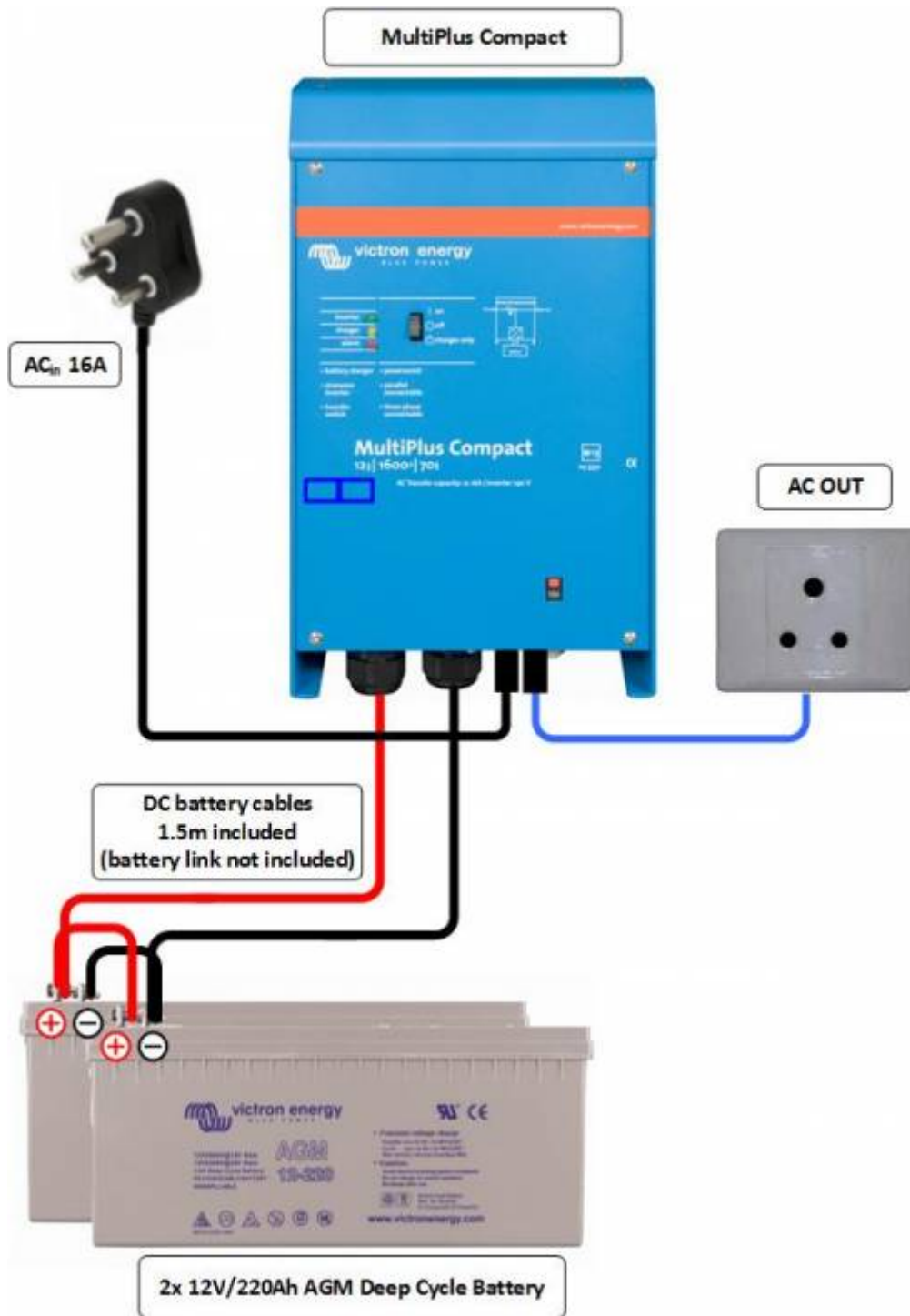

### Notes for batteries

- We recommend using deep-cycle GEL or AGM batteries. At least 200Ah blocks.
- Cable cross section: The Multiplus 1600 comes with 35mm<sup>2</sup> battery cables of 1.5m included. If longer cables are needed, a cable with a thicker cross section may be needed. Check the table in this document: [For more information on battery cables](#)

### Optional extra 1: Simple monitoring

For simple monitoring and remote on/off switching the Digital Multi Control can be used. This is

installed using 1 RJ45 UTP network cable. The panel can be used to turn the Multi on and off, though we advise to disable this in a software setting to prevent accidental switch-offs, and to see the operational state, including a low battery alarm.

- DMC000200000R - [Digital Multi Control 200/200A GX](#)
- ASS030066xxx - RJ45 UTP network cable, available from 0.3 to 30m. See [our pricelist](#) for all available lengths.

### Optional extra 2: Advanced monitoring

If you want to do more advanced monitoring or even logging and remote monitoring via Internet, you can install the Color Control GX. This is a graphical display which can connect to almost all Victron equipment and the internet. For more information and details see the product pages.

- BPP000300100R - [Color Control GX](#)
- ASS030066xxx - RJ45 UTP network cable, available from 0.3 to 30m. See [our pricelist](#) for all available lengths.

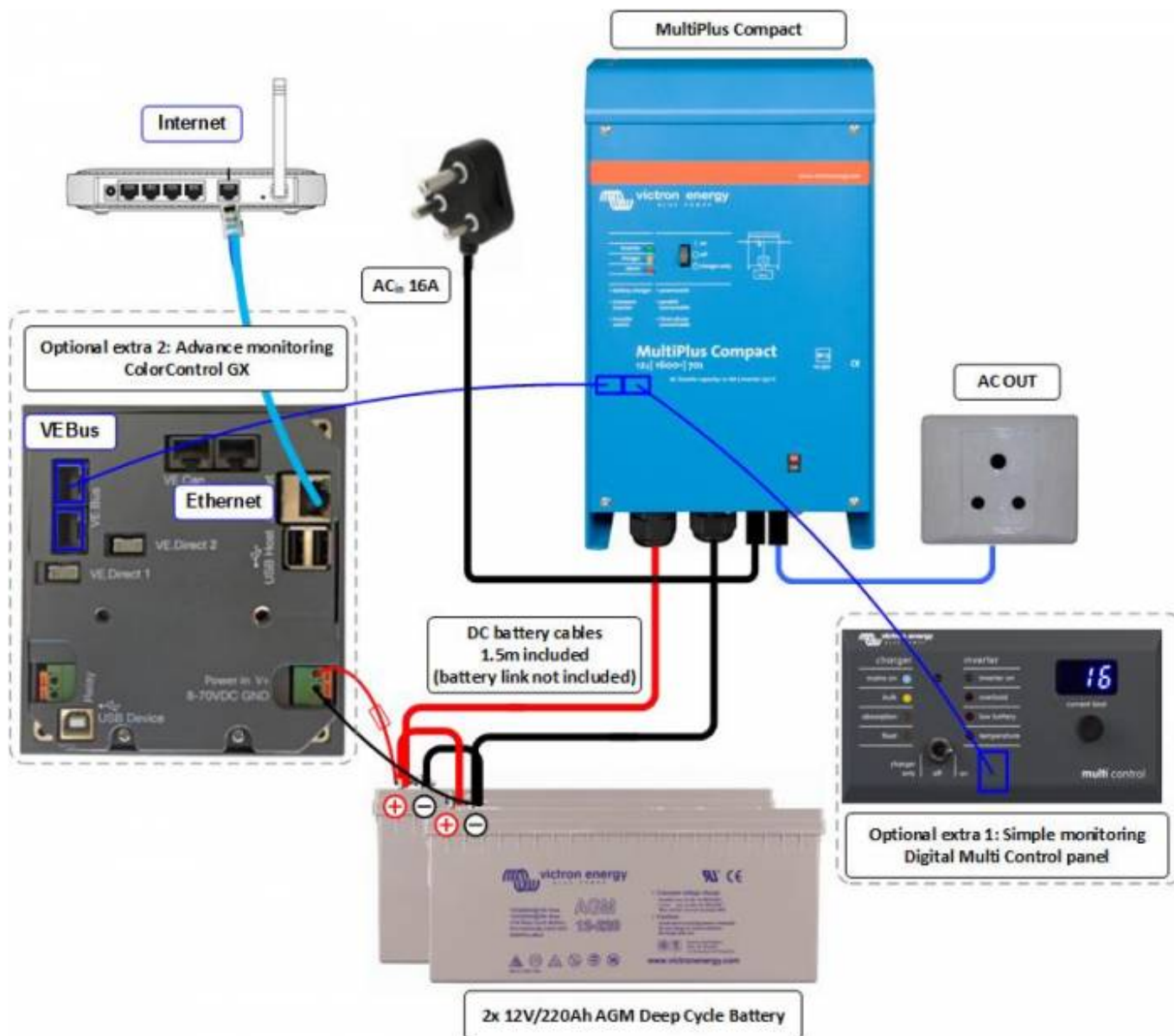

## Installation

Connect the AC input to the mains. Connect the AC output to the loads you want to backup. Connect the battery cables to the battery. Read the manual for details on how to safely connect the batteries\|. See drawing below for minimum wire gauge/cross section to be used. Put the batteries not outside, in the shade, cooled, not under the MultiPlus, in a ventilated area etc (needs checking! Andre, what do you normally advise here)

\*And Andre, are there other advices that you give?\*

## Software configuration

For the system to work correctly some default settings need to be changed using the program VEConfigure3. This can be downloaded from our website. On our website there is also documentation available that explains how VEConfigure should be used.

- [software download VEConfigure](#)
- [A guide to VEConfigure](#)
- [Updating VE.Bus products](#)

MARTIJN: MK2!?!?!?

## Settings

Only a few settings need to be changed. See the list below. Some screenshots are displayed to help you if you are a first time user.

- Disable overrule by remote → General tab
- Change DC input low shutdown to 10.8 volts → Inverter tab
- Change DC input low restart to 11.8 volts → Inverter tab
- Change DC input low pre-alarm to ???.? volts → Inverter tab
- Charge current can be left at standard setting → Charger tab
- Enable battery monitor and set correct Battery capacity → Battery monitor tab

## General tab



**Battery monitor tab and Inverter tab**

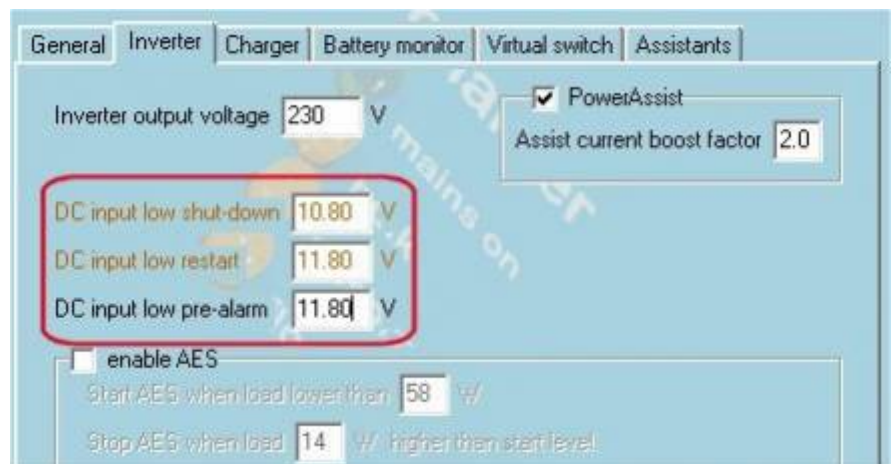



## DISQUS Comments

~~DISQUS~~

From:  
<https://www.victronenergy.com/live/> - **Victron Energy**

Permanent link:  
[https://www.victronenergy.com/live/drafts:sa\\_system:backup1600-mp?rev=1429082818](https://www.victronenergy.com/live/drafts:sa_system:backup1600-mp?rev=1429082818)

Last update: **2015-04-15 09:26**

