

Multigrid Troubleshooting FAQ

DRAFT

The Victron Multigrid is very similar to the Multiplus. There are a few key differences that are required in some grid connected markets, and these additional features can lead to some confusion and troubles during installation, commissioning and operation.

This FAQ seeks to address the most common issues that arise, explain why they do, and how to correct them.

The first step is always to be sure that all Victron equipment is running the latest firmware versions. These are available from <https://professional.victronenergy.com>

The following information is all subject to local codes, standards, regulations and guidelines. These vary widely and it is not possible for Victron to give specific advice for your area. Your local Victron Distributor may have additional, locally specific information. IT IS THE **RESPONSIBILITY OF THE INSTALLER** to make sure that all their work is performed in compliance with their specific regional responsibilities.

This information refers to circuits that contain potentially fatal voltages and are intended for use by suitably qualified and trained professionals. Appropriate safety procedures should be followed at all times. If in doubt, do not proceed and seek the support of another technician.

Error 11.

Error 11 refers to a fault state where an internal relay check is performed to assess if there is a functioning neutral earth link in the electrical system. If a neutral earth link is not found, the Multigrid will engage the relay and create this link.

There can only be 1 earth, neutral link bond (NEM) in each installation. For example, In Australia, this link is made inside the supply mains distribution box.

In the event of a detected grid outage, the Multigrid will disconnected (“island”) the active AND the neutral on the AC-Input to the inverter. This also serves to remove the NEM connection, which needs to then be quickly re-created inside the Multigrid for the AC-Out. This is to maintain safety features on the electrical circuit such as residual current devices (RCDs).

It is important for the operation of this relay, that the neutral links on the AC input and AC output of the Multigrid remain isolated from each other.

If there is a connection detected between these two neutrals, it will trigger Error 11, and the unit will shut down until it is corrected.

If you are adding the Multigrid to existing wiring and intend to separate the essential (AC-Out) and non-essential (AC-In) loads; It is recommended to disconnect all existing distribution board wiring for these and re-wire the board with them structurally separated and clearly labelled.

To be clear, that is two separated, neutral buses. One for the mains grid supply and one for the AC-Out 'Essential Loads' that will remain on during a grid outage.

It will only take one instance of a circuit with the active connected to the AC-out, while the neutral is connected to the AC-in neutral bus (or vice versa) to lead to re-occurring error 11 issues.

Furthermore, future circuit additions by electricians who are unfamiliar with the separated neutral links could lead to issues arising with an otherwise functioning installed system.

If you are not separating the loads into Essential and Non-essential, and all loads will be connected to the AC-Out of the Multigrid, then you will STILL have 2 separate neutrals. However the ONLY load on the Main Grid Supply neutral will be the Multigrid AC-Input.

This will still cause the NEM link to be broken during an outage, and the new NEM link to be made inside the Multigrid.

You will need to run two Active and two Neutrals to the Multigrid, one for the AC-In and one for the AC-out. They will share the same common earth.

Multigrid internal wiring diagram

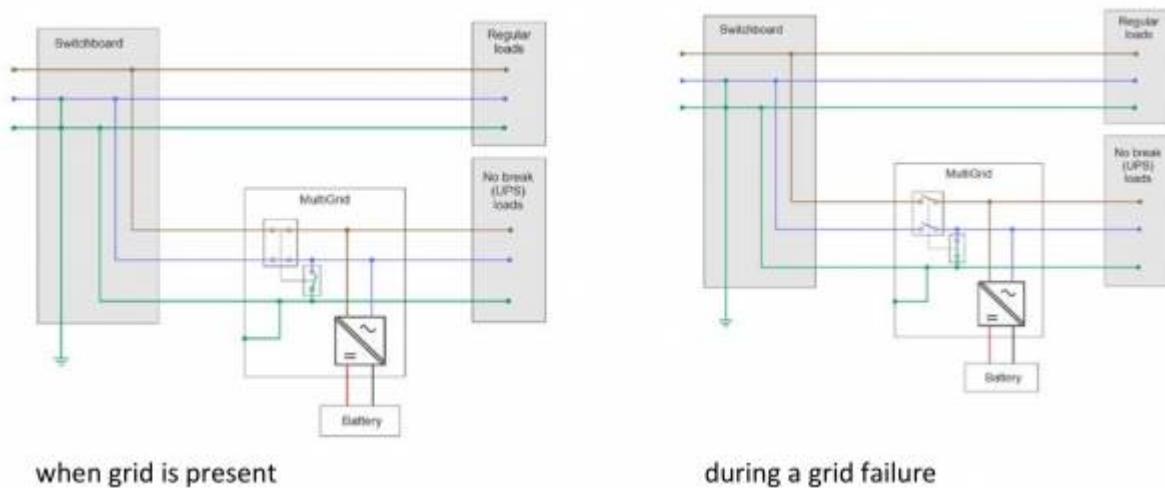

Nuisance Tripping of Residual Current Devices (RCDs)

The test required for the Neutral Earth link introduces a small amount of Neutral Earth current leakage. This is estimated to be less than 10 mA, well below the normal RCD trip threshold of 30 mA.

However, there may be other devices on the electrical circuit which are also introducing a small 'below threshold' amount of neutral earth leakage, and the cumulative effect of the relay check can cause unpredictable nuisance tripping of RCD's.

As the Multigrid relay check is an essential safety feature, the other devices that are contributing to the total leakage about 30 mA will need to be identified and removed from the system.

Some common troublesome appliances to check and disconnect first when troubleshooting are:

- Surge Protected Power-boards
- Old refrigerator compressors

- Electric hot water units (due to their own earth differential from the main earth stake).

If removing/disconnecting those devices does not stop nuisance trips, individual load circuits will need to be megger tested for insulation leakage. Remember, even though the circuits individually may be within acceptable limits, accumulative leakage, combined with that introduced by the relay test can exceed the 30mA limit.

If multiple circuits sharing a single RCD each have a small leakage, replace it with RCBO's on each of the circuits to bring down the total to within the limits.

From:
<https://www.victronenergy.com/live/> - **Victron Energy**

Permanent link:
https://www.victronenergy.com/live/drafts:multigrid_faq?rev=1548150151

Last update: **2019-01-22 10:42**

