

Automatic Generator start/stop

1. Which relay and control to use?

Various Victron products have functions to automatically signal when to start and stop a generator. Here is advice on when to use which product and method.

When there is a [Venus-device](#) (CCGX, Venus GX, or other) in the system, the best option is to use its [Generator Start Stop mechanism](#). Its the most feature-rich generator start/stop system that we have to offer. It provides for basic functions as starting and stopping on Battery State of Charge, Battery voltage as well as High load situations. And also has many advanced features, including automatic test runs and silent times.

The next most used option is a BMV-700 Battery Monitor or similar model. It can start the generator on low battery voltage and/or low battery state of charge. See the [BMV-700 manual](#) for configuration.

The Multis, MultiPlus-IIs, Quattros, EasySolars and the rest of the VE.Bus family also have Generator start/stop feature with a relay. There are two different ways to configure them:

1. [Generator Start/stop function of the Virtual Switch](#) (recommended)
2. [Generator start/stop Assistant](#) (more advanced / complex)

Lastly, its of course also possible to combine above mentioned methods, by wiring the open contacts in parallel to each other, or in series, to the Generator.

2. How to wire a a genset with three-wire interface

All above products and devices have a single relay; that require a generator that starts and keeps running when- and while the relay is closed; and stops again when opened. Or the other way around.

When having a generator that requires a start pulse and a stop pulse, such as for example Cummins/Onan generators; additional wiring is required.

To start such a genset, the open/close contact needs to be converted into a start and stop pulse. Below solution, using standard available timing relays, does exactly that: when the open/close contact closes it generates the start pulse, and when the open/close contact opens again it generates the stop pulse.

Note that this solution should only be used on gensets that have their OWN control panel monitoring and automatically stopping on loss of oil pressure and other sensors. In other words: do not wire this directly to the starter motor and fuel solenoid.

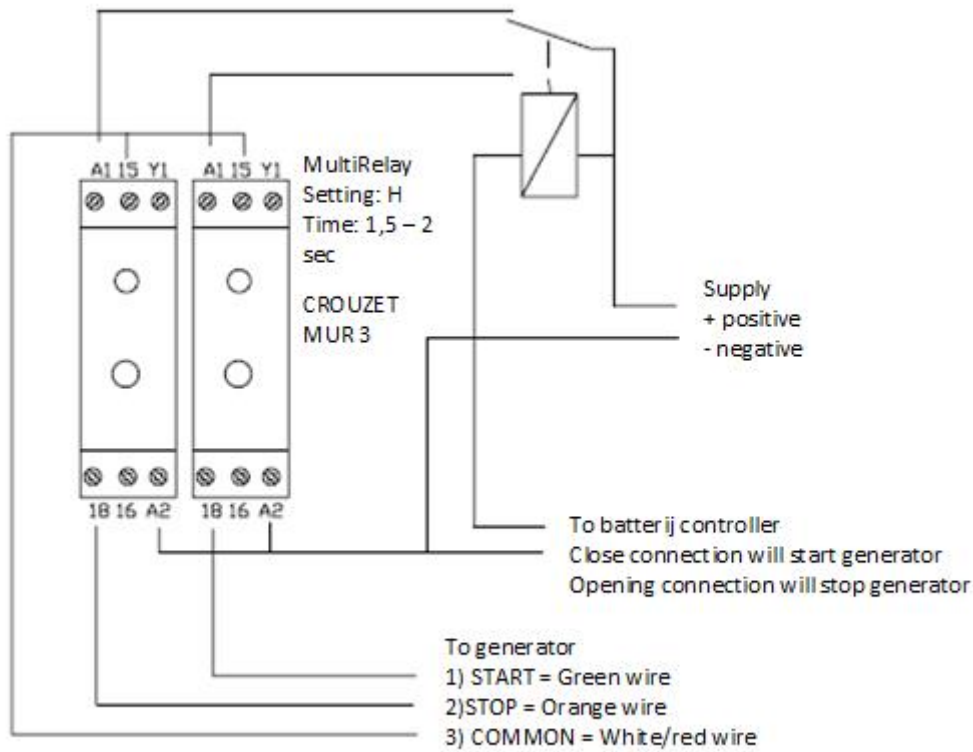
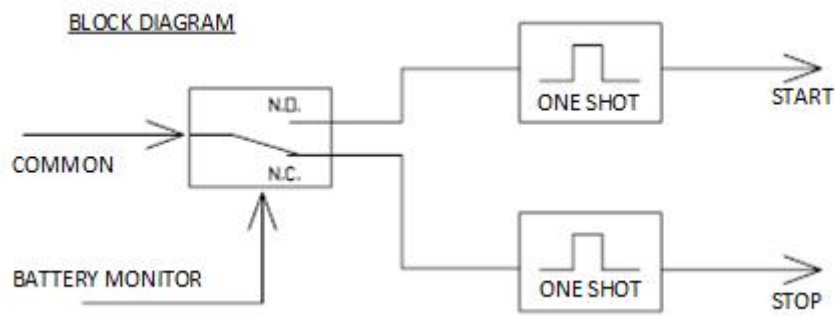

Alternative using Assistants

(provided by Thierry Cortasa)

hy

just for information, one solution using multiplus relay for start stop a three-wire generator. i use k1 and k2 relais and relai programmable assistant

first to close k1 if voltage under 24v (for exemple) segond to open k1 if ac1 available third to close k2 if voltage uper 27v (for exemple) last to open k2 if ac1 not available

in this case you have a three-wire system with out any think more needed !

i have some systeme using this solution and all looks ok

DISQUS

~~DISQUS~~

From:

<https://www.victronenergy.com/live/> - **Victron Energy**

Permanent link:

<https://www.victronenergy.com/live/auto-generator-start-stop:start?rev=1548547037>

Last update: **2019-07-20 05:09**

