

# Automatic Generator start/stop

Various Victron products have functions to automatically signal when to start and stop a generator. Here is advice on when to use which product and method.

When there is a [Venus-device](#) (CCGX, Venus GX, or other) in the system, the best option is to use that [Generator Start Stop mechanism](#). Its the most feature-rich generator start/stop system that we have to offer. It provides for basic functions as starting and stopping on Battery State of Charge, Battery voltage as well as High load situations. And also has many advanced features, including automatic test runs and silent times.

The next most used option is a BMV-700 Battery Monitor or similar model. It can start the generator on low battery voltage and/or low battery state of charge. See the [BMV-700 manual](#) for configuration.

Also the VE.Bus Inverters, Multis and Quattros offer a Generator start/stop mechanism. They have the relatively easy to configure and quite flexible Generator Start/stop function of the Virtual Switch. For more information, see ????. And besides that there is the more advanced [Generator start/stop Assistant](#)

Lastly, its of course also possible to combine above mentioned methods, by wiring the open contacts in parallel to each other, or in series, to the Generator.

## Starting a genset with three-wire interface

For example Cummins/Onan gensets, that need a start pulse and a stop pulse.

To start such a genset, the open/close contact needs to be converted into a start and stop pulse. Below solution, using standard available timing relays, does exactly that: when the open/close contact closes it generates the start pulse, and when the open/close contact opens again it generates the stop pulse.

Note that this solution should only be used on gensets that have their OWN control panel monitoring and automatically stopping on loss of oil pressure and other sensors. In other words: do not wire this directly to the starter motor and fuel solenoid.

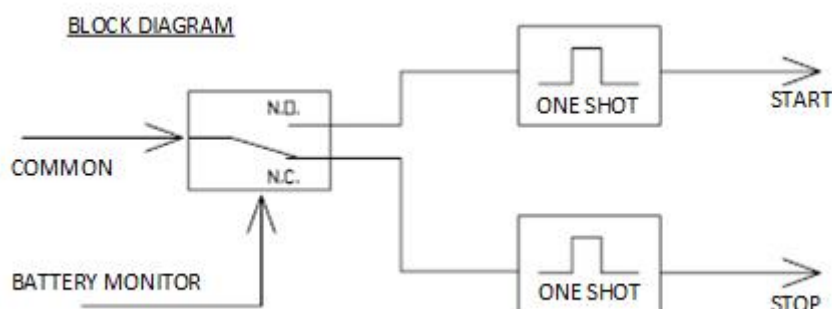

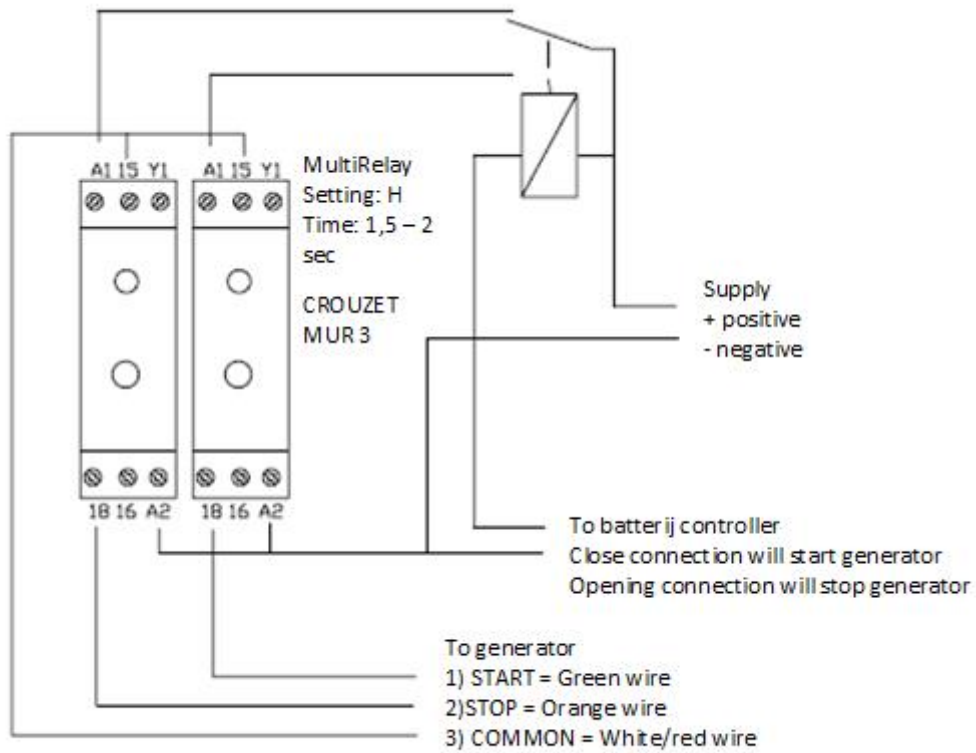

## DISQUS

~~DISQUS~~

From:  
<https://www.victronenergy.com/live/> - **Victron Energy**

Permanent link:  
<https://www.victronenergy.com/live/auto-generator-start-stop:start?rev=1544225881>

Last update: **2018-12-08 00:38**

