

Quattro

12		5000		200		2x60		120/240V
24		5000		120		2x60		120/240V
48		5000		70		2x60		120/240V

Copyrights © 2008 Victron Energy B.V.
All Rights Reserved

This publication or parts thereof may not be reproduced in any form, by any method, for any purpose.

For conditions of use and permission to use this manual for publication in other than the English language, contact Victron Energy B.V.

VICTRON ENERGY B.V. MAKES NO WARRANTY, EITHER EXPRESSED OR IMPLIED, INCLUDING BUT NOT LIMITED TO ANY IMPLIED WARRANTIES OF MERCHANTABILITY OR FITNESS FOR A PARTICULAR PURPOSE, REGARDING THESE VICTRON ENERGY PRODUCTS AND MAKES SUCH VICTRON ENERGY PRODUCTS AVAILABLE SOLELY ON AN "AS IS" BASIS.

IN NO EVENT SHALL VICTRON ENERGY B.V. BE LIABLE TO ANYONE FOR SPECIAL, COLLATERAL, INCIDENTAL, OR CONSEQUENTIAL DAMAGES IN CONNECTION WITH OR ARISING OUT OF PURCHASE OR USE OF THESE VICTRON ENERGY PRODUCTS. THE SOLE AND EXCLUSIVE LIABILITY TO VICTRON ENERGY B.V., REGARDLESS OF THE FORM OF ACTION, SHALL NOT EXCEED THE PURCHASE PRICE OF THE VICTRON ENERGY PRODUCTS DESCRIBED HERE IN.

Victron Energy B.V. reserves the right to revise and improve its products as it sees fit. This publication describes the state of this product at the time of its publication and may not reflect the product at all times in the future

1. SAFETY INSTRUCTIONS

In general

Please read the documentation supplied with this product first, so that you are familiar with the safety signs and directions before using the product.

This product is designed and tested in accordance with international standards. The equipment should be used for the designated application only.

WARNING: DANGER OF ELECTRICAL SHOCK

The product is used in combination with a permanent energy source (battery). Even if the equipment is switched off, a dangerous electrical voltage can occur at the input and/or output terminals. Always switch the AC power off and disconnect the battery before performing maintenance.

The product contains no internal user-serviceable parts. Do not remove the front panel and do not put the product into operation unless all panels are fitted. All maintenance should be performed by qualified personnel.

Never use the product at sites where gas or dust explosions could occur. Refer to the specifications provided by the manufacturer of the battery to ensure that the battery is suitable for use with this product. The battery manufacturer's safety instructions should always be observed.

WARNING: do not lift heavy objects unassisted.

Installation

Read the installation instructions before commencing installation activities.

This product is a safety class I device (supplied with a ground terminal for safety purposes). **Its AC input and/or output terminals must be provided with uninterruptable grounding for safety purposes. An additional grounding point is located on the outside of the product.** If it can be assumed that the grounding protection is damaged, the product should be taken out of operation and prevented from accidentally being put into operation again; contact qualified maintenance personnel.

Ensure that the connection cables are provided with fuses and circuit breakers. Never replace a protective device by a component of a different type. Refer to the manual for the correct part.

Check before switching the device on whether the available voltage source conforms to the configuration settings of the product as described in the manual.

Ensure that the equipment is used under the correct operating conditions. Never operate it in a wet or dusty environment. Ensure that there is always sufficient free space around the product for ventilation, and that ventilation openings are not blocked.

Install the product in a heatproof environment. Ensure therefore that there are no chemicals, plastic parts, curtains or other textiles, etc. in the immediate vicinity of the equipment.

Transport and storage

On storage or transport of S product, ensure that the mains supply and battery leads are disconnected.

No liability can be accepted for damage in transit if the equipment is not transported in its original packaging.

Store the product in a dry environment; the storage temperature should range from -20°C to 60°C .

Refer to the battery manufacturer's manual for information on transport, storage, charging, recharging and disposal of the battery.

2. DESCRIPTION

2.1 In general

Two AC inputs with integrated transfer switch

The Quattro can be connected to two independent AC sources, for example shore-side (grid-) power and a generator, or two generators. The Quattro will automatically connect to the active source.

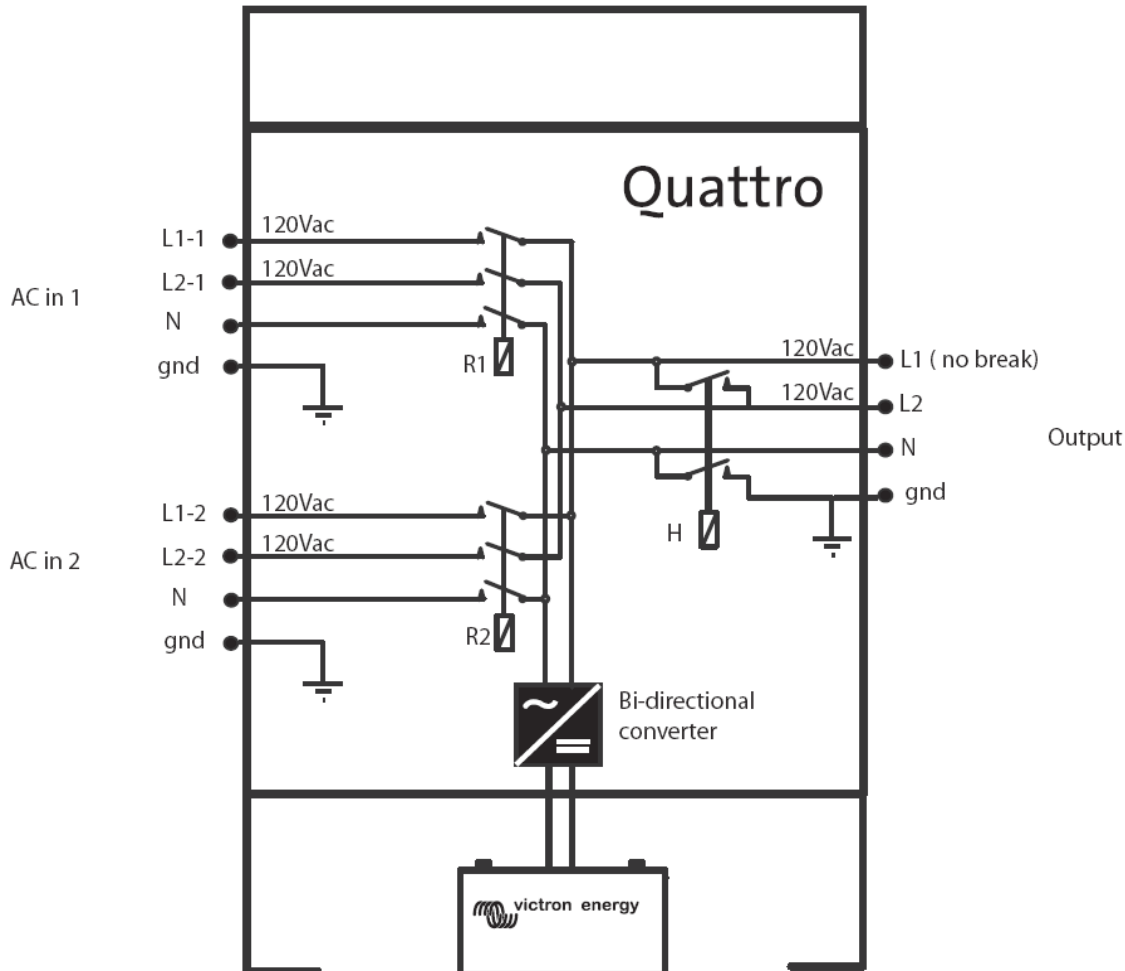

Figure 1: Block diagram

Accepts several input voltages (See fig 1)

Each AC input can be supplied from:

- A 120/240V split phase source. Phase angle between the two 120V legs: 180 degrees. Maximum input current: 60A per leg.
- A 120/208V two leg three phase source. Phase angle between the two 120V legs: 120 degrees. Maximum input current: 60A per leg.
- Two in-phase 120V legs with common neutral. In this case the phase angle between the two 120V legs is 0 degrees. Maximum input current: 60A **total** (otherwise the neutral input would be overloaded).
- A 120V single phase source. Maximum input current: 60A.

The AC inputs can be connected to a different type of supply: one input may for example be connected to a split phase source, and the other to a single phase source.

When an AC source is available, the Quattro will feed through the AC to its output. The output will therefore be equal to the AC input.

When AC is available on both inputs, the Quattro will connect to AC-in-1.

The inverter/charger connects to the neutral and the preferred input leg (L1-1 of input 1 or L1-2 of input 2). Power needed to charge the batteries will therefore be drawn from L1-1 or L1-2.

The Quattro switches to inverter operation when no AC source is available. The inverter output is 120V single phase. In Invert mode, the Quattro connects both output legs (L1 and L2) together (with relay H) to provide 120 VAC to loads on either leg. In invert mode there is no voltage between L1 and L2. Any 240VAC or 208VAC loads will therefore be supplied only when the Quattro is supplied by a split phase 120/240V or 120/208V source. This prevents heavy loads such as water heaters or 240V air conditioners from discharging the battery.

The Quattro provides seamless transfer (no-break functionality) on output L1. Output L2 connects to the inverter after a short delay.

Note: this product is not suitable for a single phase 230V or 240V supply. (see section 2.3)

Automatic and uninterruptible switching (on phase L1 only)

In the event of a supply failure or when the generating set is switched off, the Quattro will switch over to inverter operation and take over the supply of the connected devices. This is done so quickly that operation of computers and other electronic devices is not disturbed (Uninterruptible Power Supply or UPS functionality). This makes the Quattro highly suitable as an emergency power system in industrial and telecommunication applications.

Virtually unlimited power thanks to parallel operation

Up to 6 Quattro's can operate in parallel. Six units 24/5000/120, for example, will provide 25kW / 30kVA output power and 720 Amps charging capacity.

Three phase capability

Three units can be configured for three-phase output. But that's not all: up to 6 sets of three units can be parallel connected to provide 75kW / 90kVA inverter power and more than 2000A charging capacity.

PowerControl – maximum use of limited shore current

For each AC input a maximum current can be set. The Quattro then takes other power users into account, and only uses 'surplus' current for charging purposes.

When AC is present on one of the inputs, the inverter/charger of the Quattro connects to the preferred input leg (L1-1 or L1-2). PowerControl will therefore be active on the preferred input leg only.

- L1-1 of input AC-in-1, to which usually a generating set is connected, can be set to a fixed maximum with DIP switches, with VE.Net or with a PC, so that the generating set is never overloaded.
- L1-2 of input AC-in-2 can also be set to a fixed maximum. In mobile applications (ships, vehicles), however, a variable setting by means of a Multi Control Panel will usually be selected. In this way the maximum current can be adapted to the available shore current in an extremely simple manner.

PowerAssist – Extended use of your generating set and shore current: the Quattro 'co-supply' feature

The Quattro operates in parallel with the generating set or the grid/shore connection. A current shortfall is automatically compensated: the Quattro draws extra power from the battery and helps along.

Solar energy

The Quattro is extremely suitable for solar energy applications. It can be used for building autonomous systems as well as grid-connected systems.

Emergency power or autonomous operation on mains failure

Houses or buildings with solar panels or a combined micro-scale heating and power plant (a power-generating central heating boiler) or other sustainable energy sources have a potential autonomous energy supply which can be used for powering essential equipment (central heating pumps, refrigerators, deep freeze units, Internet connections, etc.) during a grid-power failure. A problem in this regard, however, is that a grid connected solar inverter and/or micro-scale heating and power plants drop out as soon as the mains supply fails. With a Quattro and batteries, this problem can be solved in a simple manner: **the Quattro can replace the grid during a power failure.** When the sustainable energy sources produce more power than needed, the Quattro will use the surplus to charge the batteries; in the event of a shortfall, the Quattro will supply additional power from the battery.

Multi-functional relay

The Quattro is equipped with a multi-functional relay that by default is programmed as an alarm relay. The relay can be programmed for all kinds of other applications, for example as a starter relay for a generating set.

Programmable with DIP switches, VE.Net panel or personal computer

The Quattro is supplied ready for use. Three options are available for changing certain settings if desired:

- The most important settings (including parallel operation of up to three devices and split phase or 3-phase operation) can be changed in a very simple manner, using DIP switches.
- All settings, with exception of the multi-functional relay, can be changed with a VE.Net panel.
- All settings can be changed with a PC and free of charge software, downloadable from our website www.victronenergy.com

2.2 Battery charger

Adaptive 4-stage charging characteristics: bulk – absorption – float – storage

The microprocessor-driven adaptive battery management system can be adjusted for various types of batteries. The adaptive function automatically adapts the charging process to battery use.

The right amount of charge: variable absorption time

When only shallow discharges occur (a yacht connected to shore power for example) the absorption time is kept short in order to prevent overcharging of the battery. After a deep discharge the absorption time is automatically increased to make sure that the battery is completely recharged.

Preventing damage due to excessive gassing: the BatterySafe mode

If, in order to quickly charge a battery, a high charge current in combination with a high absorption voltage has been chosen, the Phoenix charger will prevent damage due to excessive gassing by automatically limiting the rate of voltage increase once the gassing voltage has been reached

Less maintenance and aging when the battery is not used: the storage mode

The storage mode kicks in whenever the battery has not been subjected to discharge during 24 hours. In the storage mode float voltage is reduced to 2,2 V/cell (13,2 V for 12 V battery) to minimise gassing and corrosion of the positive plates. Once a week the voltage is raised back to the absorption level to 'equalize' the battery. This feature prevents stratification of the electrolyte and sulphation, a major cause of early battery failure.

Two DC outputs for charging two batteries

The Quattro has two DC outputs, one of which can supply the full output current. The second output, intended for charging a starter battery, is limited to 4A and has a slightly lower output voltage.

To increase battery life: temperature compensation

Every Quattro comes with a battery temperature sensor. When connected, charge voltage will automatically decrease with increasing battery temperature. This feature is especially recommended for sealed batteries and/or when important fluctuations of battery temperature are expected.

Battery voltage sense

In order to compensate for voltage loss due to cable resistance, the Quattro has a voltage sense facility so that the battery always receives the correct charge voltage.

More on batteries and charging

Our book 'Energy Unlimited' offers further information on batteries and battery charging, and is available free of charge at Victron Energy (see www.victronenergy.com). For more information on adaptive charging characteristics, please refer to the 'Tech Info' page on our website

2.3 Overview of AC power options

Option 1 (see fig 1)

As explained in section 2.1, the 120/240V Quattro can be connected to the standard American single phase and split phase AC supplies. When in inverter mode, however, the two live outputs are connected together to provide in phase 120 VAC on both lines. The line to line voltage will be zero. Any 240VAC or 208VAC loads will therefore be supplied only when the Quattro is supplied by a split phase 120/240V or 120/208V source. This prevents heavy loads such as 240V water heaters or 240 V air conditioners from discharging the battery.

The input and output options are summarized below:

Option 1: 120/240V Quattro or Multi			
AC source (input)	Does system connect to AC source?	Power for battery charging taken from	Output
120/240V 3wire + ground (split phase 60Hz)	Yes	Preferred 120V input leg (L1-1 or L1-2)	120/240V 3wire + ground 60Hz (output = input)
120/208V 3wire + ground (three phase two leg 60Hz)	Yes	Preferred 120V input leg (L1-1 or L1-2)	120/208V 3wire + ground 60Hz (output = input)
240V 2 wire + ground (single phase 60Hz)	No		120V 2 wire + ground 60Hz (inverter mode)
230V 2 wire + ground (single phase 50Hz)	No		120V 2 wire + ground 60Hz (inverter mode)
208V 2 wire + ground (single phase 60Hz)	No		120V 2 wire + ground 60Hz (inverter mode)
120V 2 wire + ground (single phase 60Hz)	Yes (if connected to preferred input leg)	120V input	120V 2 wire + ground 60Hz (output = input)
Not available (no input)	No		120V 2 wire + ground 60Hz (inverter mode)

PowerControl and PowerAssist functionality will be available on L1-1 and L1-2

Note: If the requirement is to continue supplying 240V or 208V equipment in inverter mode, a different system configuration must be chosen: see option 2 and option 3.

Option 2a,b: two stacked units (see fig 2a and 2b)

Option 2a: One alternative is to stack 2 Quattro's or Multi's, each supplied by one 120V leg when a 120/240V or 120/208V AC source is available. The stacked units will each continue to supply 120V from the battery when there is no external AC source available. The Quattro's or Multi's are capable to synchronize and connect to both 120/240V and 120/208V AC, whatever is available. When connected to the AC source, the output will be equal to the input. When operating from battery, the output will either be 120/240V or 120/208V depending on whether the system has been configured to operate with a 180 degrees or a 120 degrees phase shift.

If only one 120V leg is available at the AC input, one unit will connect to it, and the other unit will operate on battery power. System output will be 120/240V or 120/208V, depending on configuration. Power from the 120V leg that is available will be used to charge the battery, compensating for power taken from the battery by the second unit.

Option 2b: This option, with an additional input 120/240V autotransformer, is recommended in case connection to 230V or 240V single phase should also be possible.

Option 2a: Two stacked 120V or 120/240V Quattro's or Multi's

AC source (input)	Does system connect to AC source?	Power for battery charging taken from	Output
120/240V 3wire + ground (split phase 60Hz)	Yes	Both 120V legs	120/240V 3wire + ground 60Hz (output = input)
120/208V 3wire + ground (three phase two leg 60Hz)	Yes	Both 120V legs	120/208V 3wire + ground 60Hz (output = input)
240V 2 wire + ground (single phase 60Hz)	No (neutral not available, see 2b)		120/240V 3wire + ground 60Hz (inverter mode)
230V 2 wire + ground (single phase 50Hz)	No (neutral not available, see 2b)		120/240V 3wire + ground 60Hz (inverter mode)
208V 2 wire + ground (single phase 60Hz)	No (neutral not available, see 2b)		120/240V 3wire + ground 60Hz (inverter mode)
120V 2 wire + ground (single phase 60Hz)	Yes (1 off 2 units only)	120V input	120/240V 3wire + ground 60Hz (one unit in inverter mode)
Not available (no input)	No		120/240V 3wire + ground 60Hz (inverter mode)

PowerControl and PowerAssist functionality will be available on both input phases

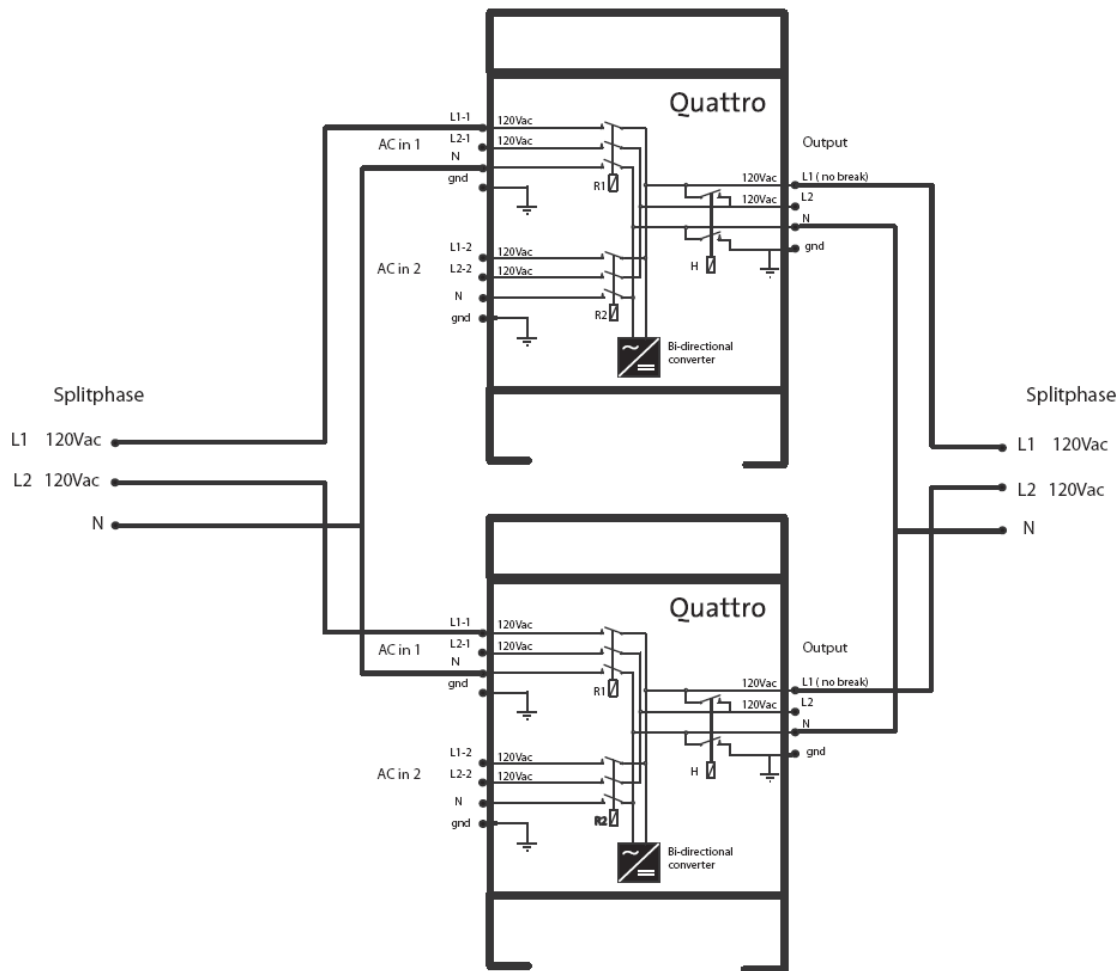

Figure 2a: Two stacked 120/240V Quattro's (option 2a)
 Ground cables and interconnection for synchronization not shown
 Connection to second AC source not shown.

Option 2b: Two stacked 120V or 120/240V Quattro's or Multi's with additional 120/240V input autotransformer			
AC source (input)	Does system connect to AC source?	Power for battery charging taken from	Output
120/240V 3wire + ground (split phase 60Hz)	Yes (neutral wire should not be connected)	240V	120/240V 3wire + ground 60Hz
120/208V 3wire + ground (three phase two leg 60Hz)	Yes (neutral wire should not be connected)	208V	104/208V 3wire + ground 60Hz (180 degrees split phase output)
240V 2 wire + ground (single phase 60Hz)	Yes (neutral comes from 120/240V autotransformer)	240V	120/240V 3wire + ground 60Hz
230V 2 wire + ground (single phase 50Hz)	Yes (neutral comes from 120/240V autotransformer)	230V	115/230V 3wire + ground 50Hz
208V 2 wire + ground (single phase 60Hz)	Yes (neutral comes from 120/240V autotransformer)	208V	104/208V 3wire + ground 60Hz
120V 2 wire + ground (single phase 60Hz)	No		120/240V 3wire + ground 60Hz
Not available (no input)	No		120/240V 3wire + ground 60Hz (inverter mode)

PowerControl and PowerAssist functionality will be available on the single phase input of the auto transformer

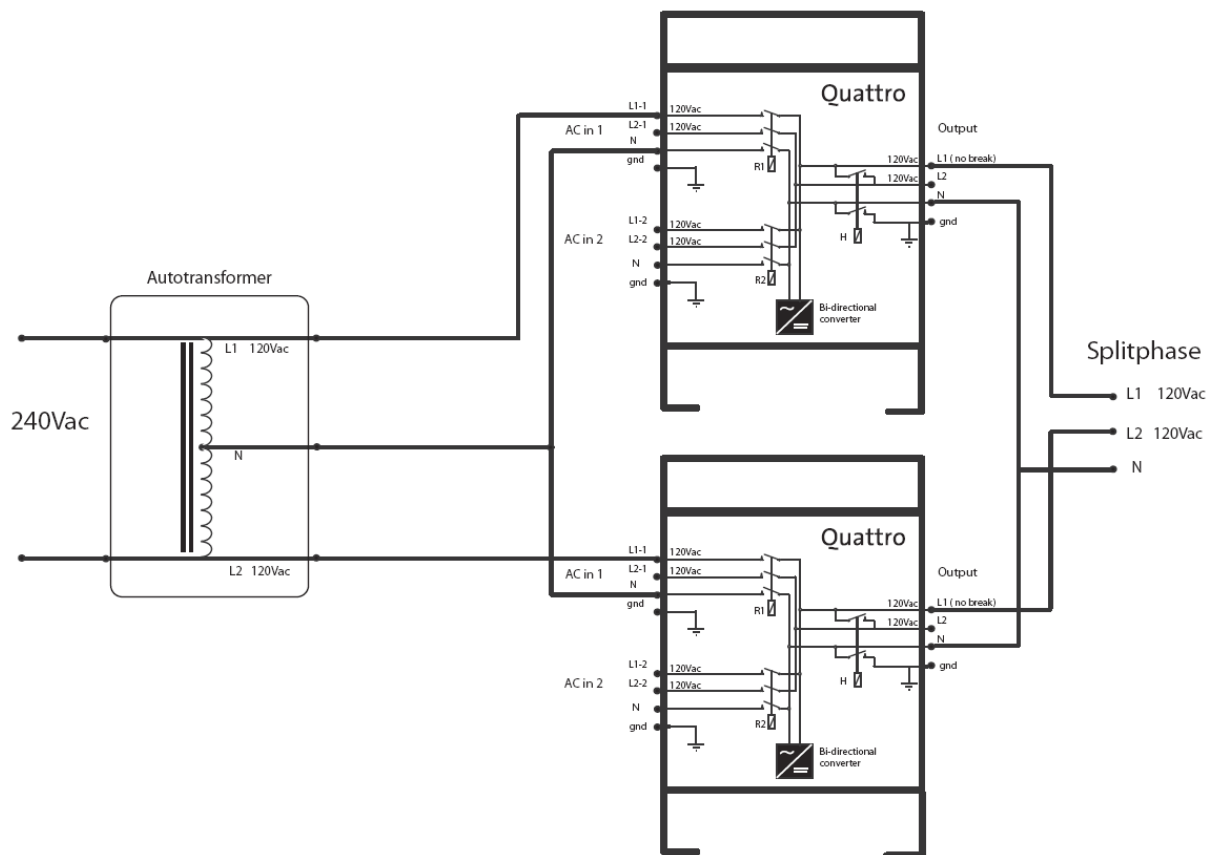

Figure 2b: Two stacked 120/240V Quattro's with input autotransformer (option 2b)
 Ground cables and interconnection for synchronization not shown
 Connection to second AC source not shown.

Option 3: Quattro or Multi with additional autotransformer (see fig 3)

The other alternative is to use a 'European' 230V/240V Quattro or Multi. The unit will connect to 240V or 208V. The output when operating on battery can be set to 240V or 208V single phase. An additional autotransformer will be needed to convert 240V single phase to 120/240V split phase if 120V loads also need to be supplied. (Remark: a 208V output cannot be transformed to 120/208V with an 120/240V auto transformer) The internal output grounding relay must be disabled and replaced by an external grounding relay that will ground the neutral of the 120/240V auto transformer when operating on battery. Victron Energy does provide 120/240V autotransformers with in-built neutral to ground relay.

Advantages of this configuration:

- Only one inverter/charger needed.
- Severe load imbalance between the two output legs is acceptable if the autotransformer is adequately sized.

Option 3: 'European' Quattro or Multi with additional 120/240V output autotransformer			
AC source (input)	Does system connect to AC source?	Power for battery charging taken from	Output from autotransformer
120/240V 3wire + ground (split phase 60Hz)	Yes (neutral wire should not be connected)	240V	120/240V 3wire + ground 60Hz (180 degrees split phase output)
120/208V 3wire + ground (three phase two leg 60Hz)	Yes (neutral wire should not be connected)	208V	104/208V 3wire + ground 60Hz (180 degrees split phase output)
240V 2 wire + ground (single phase 60Hz)	Yes	240V	120/240V 3wire + ground 60Hz
230V 2 wire + ground (single phase 50Hz)	Yes	230V	115/230V 3wire + ground 50Hz
208V 2 wire + ground (single phase 60Hz)	Yes	208V	104/208V 3wire + ground 60Hz
120V 2 wire + ground (single phase 60Hz)	No		120/240V 3wire + ground 60Hz (inverter mode)
Not available (no input)	No		120/240V 3wire + ground 60Hz (inverter mode)

PowerControl and PowerAssist functionality will be available on the single phase input

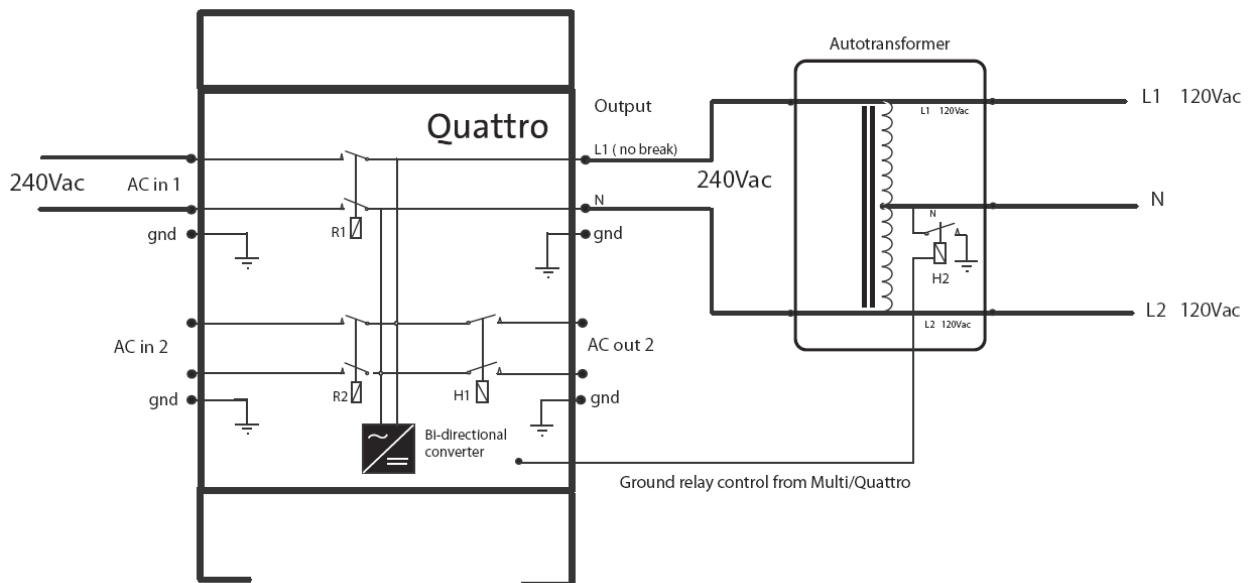

Figure 3: 'European' Quattro or Multi with additional 120/240V output autotransformer (option 3)

Ground cables and not shown
Connection to second AC source not shown.

3. Operation

3.1 “On / stand by / charger only” switch

When the switch is switched to “on”, full device operation is initiated. The inverter will turn on, and the “inverter on” LED will light.

120VAC applied to L1-1 or L1-2 (see fig 1) will be switched through to the AC output connection. The inverter is switched off, the “mains on” LED will light and charger operation will be initiated. Depending on the applicable charging mode at that time, the “bulk”, “absorption” or “float” LED will light.

If the voltage on both AC-in connections is rejected, the inverter will be switched on.

If the switch is set to “charger only”, the inverter will not turn on in the event of AC supply failure. Thus the batteries will not be discharged by the inverter.

3.2 Remote control

Remote control is possible with a simple 3-way switch or with a Multi Control panel.

The Multi Control panel has a simple rotary knob with which the maximum current of the AC-in-2 input can be set: see PowerControl and PowerAssist in Section 2.

3.3 Equalisation and forced absorption

3.3.1 Equalisation

Traction batteries require regular additional charging. In the equalisation mode, the Quattro will charge with increased voltage for one hour (1V above the absorption voltage for a 12V battery, 2V for a 24V battery). The charging current is then limited to 1/4 of the set value. **The “bulk” and “absorption” LEDs flash intermittently.**



Equalisation mode supplies a higher charging voltage than most DC consuming devices can cope with. These devices must be disconnected before additional charging takes place.

3.3.2 Forced absorption

Under certain circumstances, it can be desirable to charge the battery for a fixed time at absorption voltage level. In Forced Absorption mode, the Quattro will charge at the normal absorption voltage level during the set maximum absorption time. **The “absorption” LED lights.**

3.3.3 Activating equalisation or forced absorption

The Compact can be put into both these states from the remote panel as well as with the front panel switch, provided that all switches (on the unit, and possibly a remote switch or the switch on the Multi Control panel) are set to “on”.

NOTE: Switching from “on” to “charger only” and back, as described below, must be done quickly. The switch must be toggled such that the intermediate position is 'skipped', as it were. If the switch remains in the “off” position even for a short time, the device may be turned off. In that case, the procedure must be restarted at step 1. A certain degree of familiarisation is required when using the front switch on the Compact in particular. When using the remote panel, this is less critical.

Procedure:

1. Check whether all switches (i.e. front switch, remote switch or remote panel switch if present) are in the “on” position.
2. Activating equalisation or forced absorption is only meaningful if the normal charging cycle is completed (charger is in 'Float').
3. To activate:
 - a. Switch rapidly from “on” to “charger only” and leave the switch in this position for ½ to 2 seconds.
 - b. Switch rapidly back from “charger only” to “on” and leave the switch in this position for ½ to 2 seconds.
 - c. Switch once more rapidly from “on” to “charger only” and leave the switch in this position.
4. On the MultiPlus (and, if connected, on the MultiControl panel) the three LEDs “Bulk”, “Absorption” and “Float” will now flash 5 times.
5. Subsequently, the LEDs “Bulk”, “Absorption” and “Float” will each light during 2 seconds.
 - a. If the switch is set to “on” while the “Bulk” LED lights, the charger will switch to equalisation.
 - b. If the switch is set to “on” while the “Absorption” LED lights, the charger will switch to forced absorption.
 - c. If the switch is set to “on” after the three LED sequence has finished, the charger will switch to “Float”.
 - d. If the switch is has not been moved, the MultiPlus will remain in 'charger only' mode and switch to “Float”.

3.4 LED indications and their meaning

- LED off
- ☀ LED flashes
- LED lights

Inverter

charger		inverter	
<input type="radio"/> mains on	on	<input checked="" type="radio"/> inverter on	
<input type="radio"/> bulk	off	<input type="radio"/> overload	
<input type="radio"/> absorption		<input type="radio"/> low battery	
<input type="radio"/> float	charger only	<input type="radio"/> temperature	

The inverter is on, and supplies power to the load.

charger		inverter	
<input type="radio"/> mains on	on	<input checked="" type="radio"/> inverter on	
<input type="radio"/> bulk	off	☀ overload	
<input type="radio"/> absorption		<input type="radio"/> low battery	
<input type="radio"/> float	charger only	<input type="radio"/> temperature	

The nominal power of the inverter is exceeded. The "overload" LED flashes.

charger		inverter	
<input type="radio"/> mains on	on	<input type="radio"/> inverter on	
<input type="radio"/> bulk	off	<input checked="" type="radio"/> overload	
<input type="radio"/> absorption		<input type="radio"/> low battery	
<input type="radio"/> float	charger only	<input type="radio"/> temperature	

The inverter is switched off due to overload or short circuit.

charger		inverter	
<input type="radio"/> mains on	on	<input checked="" type="radio"/> inverter on	
<input type="radio"/> bulk	off	<input type="radio"/> overload	
<input type="radio"/> absorption		☀ low battery	
<input type="radio"/> float	charger only	<input type="radio"/> temperature	

The battery is almost empty.

charger		inverter	
<input type="radio"/> mains on	on	<input type="radio"/> inverter on	
<input type="radio"/> bulk	off	<input type="radio"/> overload	
<input type="radio"/> absorption		<input checked="" type="radio"/> low battery	
<input type="radio"/> float	charger only	<input type="radio"/> temperature	

The inverter is switched off due to low battery voltage.

charger		inverter	
<input type="radio"/> mains on	on	<input checked="" type="radio"/> inverter on	
<input type="radio"/> bulk	off	<input type="radio"/> overload	
<input type="radio"/> absorption		<input type="radio"/> low battery	
<input type="radio"/> float	charger only	☀ temperature	

The internal temperature is reaching a critical level.

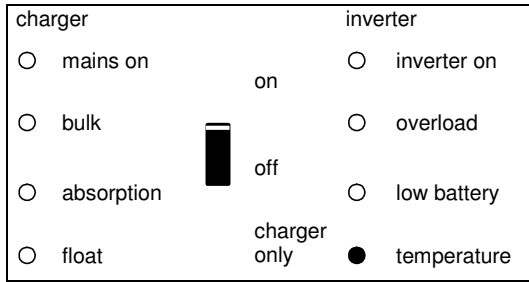

The inverter is switched off due to excessively high internal temperature.

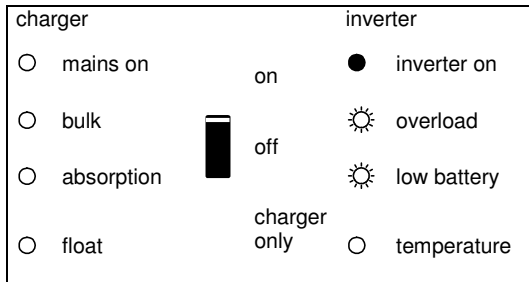

– If the LEDs flash alternately, the battery almost empty and nominal power is exceeded.
 – If “overload” and “low battery” flash simultaneously, there is an excessively high ripple voltage at the battery connection.

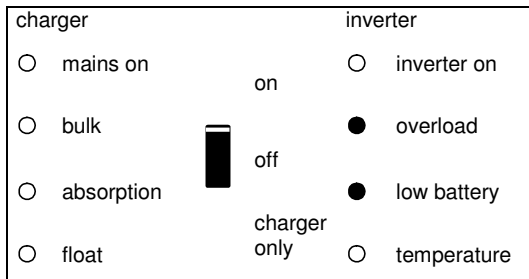

The inverter is switched off due to an excessively high ripple voltage on the battery connection.

Battery charger

charger		inverter	
<input checked="" type="radio"/> mains on	on	<input type="radio"/> inverter on	
<input checked="" type="radio"/> bulk	off	<input type="radio"/> overload	
<input type="radio"/> absorption	charger only	<input type="radio"/> low battery	
<input type="radio"/> float		<input type="radio"/> temperature	

The AC voltage on AC-in-1 or AC-in-2 is switched through, and the charger operates in bulk phase.

charger		inverter	
<input checked="" type="radio"/> mains on	on	<input type="radio"/> inverter on	
<input checked="" type="radio"/> bulk	off	<input type="radio"/> overload	
<input checked="" type="radio"/> absorption	charger only	<input type="radio"/> low battery	
<input type="radio"/> float		<input type="radio"/> temperature	

The AC voltage on AC-in-1 or AC-in-2 is switched through and the charger operates, but the set absorption voltage has not yet been reached (battery protection mode)

charger		inverter	
<input checked="" type="radio"/> mains on	on	<input type="radio"/> inverter on	
<input type="radio"/> bulk	off	<input type="radio"/> overload	
<input checked="" type="radio"/> absorption	charger only	<input type="radio"/> low battery	
<input type="radio"/> float		<input type="radio"/> temperature	

The AC voltage on AC-in-1 or AC-in-2 is switched through, and the charger operates in absorption phase.

charger		inverter	
<input checked="" type="radio"/> mains on	on	<input type="radio"/> inverter on	
<input type="radio"/> bulk	off	<input type="radio"/> overload	
<input type="radio"/> absorption	charger only	<input type="radio"/> low battery	
<input checked="" type="radio"/> float		<input type="radio"/> temperature	

The AC voltage on AC-in-1 or AC-in-2 is switched through, and the charger operates in float or storage phase.

charger		inverter	
<input checked="" type="radio"/> mains on	on	<input type="radio"/> inverter on	
<input checked="" type="radio"/> bulk	off	<input type="radio"/> overload	
<input checked="" type="radio"/> absorption	charger only	<input type="radio"/> low battery	
<input type="radio"/> float		<input type="radio"/> temperature	

The AC voltage on AC-in-1 or AC-in-2 is switched through, and the charger operates in equalisation mode.

Special indications

Set with limited input current

charger		inverter	
<input checked="" type="radio"/> mains on	on	<input type="radio"/> inverter on	
<input type="radio"/> bulk		<input type="radio"/> overload	
<input type="radio"/> absorption	off	<input type="radio"/> low battery	
<input type="radio"/> float	charger only	<input type="radio"/> temperature	

The AC voltage on AC1-in-1 or AC-in-2 is switched through. The AC-input current is equal to the load current. The charger is down-controlled to 0A.

Set to supply additional current

charger		inverter	
<input checked="" type="radio"/> mains on	on	<input checked="" type="radio"/> inverter on	
<input type="radio"/> bulk		<input type="radio"/> overload	
<input type="radio"/> absorption	off	<input type="radio"/> low battery	
<input type="radio"/> float	charger only	<input type="radio"/> temperature	

The AC voltage on AC-in-1 or AC-in-2 is switched through, but the load demands more current than the mains can supply. The inverter is now switched on to supply additional current.

4. Installation



This product may only be installed by a qualified electrical engineer.

4.1 Contents of the box

The Quattro box contains the following:

- Quattro inverter/battery charger
- Manual
- Suspension bracket
- Temperature sensor
- Warning sticker for battery charging
- Four fixing screws

4.2 Location

The Quattro should be installed in a dry, well-ventilated location, as close as possible to the batteries. The device should be surrounded by a free space of at least 10 cm for cooling purposes.



An excessively high environmental temperature has the following consequences:

- shorter lifespan
- lower charging current
- lower peak power or inverter shut-down.

Never place the device directly above the batteries.

The Quattro is suitable for wall mounting. For mounting purposes, a hook and two holes are provided at the back of the casing (see appendix G). The device can be fitted either horizontally or vertically. For optimal cooling, vertical fitting is preferred.



The inner part of the device should remain accessible after installation.

The distance between the Quattro and the battery should be as short as possible to reduce voltage loss across the battery cables to a minimum.



Install the product in a heatproof environment.

Ensure therefore that there are no chemicals, plastic parts, curtains or other textiles, etc. in the direct vicinity.



The Quattro has no internal DC fuse. The DC fuse should be installed outside the Quattro.

4.3 Requirements

- A crosshead (Phillips) screwdriver (PH 2) for removing the front panel.
- Spirit level for horizontal mounting of the support bracket for the unit.
- A flat-headed screwdriver No. 4 (1x4) for connecting the AC cables.
- A flat-headed screwdriver No. 1 (0.6x3.0) for connecting the options.
- An isolated box wrench (13 mm) for tightening the cable attachments to the negative and positive battery terminals.
- Four battery leads, including battery terminals and cable eyelets. (Considering the large power rating, two positive and two negative cables can be connected to the Quattro.)
- Three-core cable for the AC connections.

4.4 Connecting the battery cables

In order to use the full potential of the Quattro, batteries of sufficient capacity and battery cables with the correct cross-section should be used.

See table:

Model	12/5000/200	24/5000/120	48/5000/70
Recommended battery capacity (Ah)	800–2400	400–1400	200–800
Recommended DC fuse	750A	400A	200A
Recommended cross-section (mm ²) per + and - connection terminal			
0 – 5 m*	2x 90 mm ²	2x 50 mm ²	1x 70 mm ²
5 -10 m*		2x 90 mm ²	2x 70 mm ²

* '2x' means two positive and two negative cables.

Procedure

To connect the battery cables, follow the procedure below:



To prevent short circuiting of the battery, an isolated box wrench should be used.

- Loosen the four lower front panel screws at the front of the unit, and remove the lower front panel.
- Connect the battery cables: + (red) to the right-hand terminal and - (black) to the left-hand terminal (see appendix A).
- Tighten the connections after mounting the fastening parts.
- Tighten the nuts well for minimal contact resistance.

4.5 Connecting AC cables

The Quattro is a safety class I product (supplied with a ground terminal for safety purposes). **Its AC input and/or output terminals and/or grounding point on the outside of the product must be provided with an uninterruptible grounding point for safety purposes. See the following instructions in this regard.**

The Quattro is provided with a ground relay (see fig 1) that **automatically connects the N output to the casing if no external AC supply is available**. If an external AC supply is provided, the ground relay H will open before the input safety relay closes (relay R1 or R2). This ensures the correct operation of an earth leakage circuit breaker that is connected to the output.

- In a fixed installation, an uninterruptible grounding can be secured by means of the grounding wire of the AC input. Otherwise the casing must be grounded.
- In a mobile installation (for example, with a shore current plug), interrupting the shore connection will simultaneously disconnect the grounding connection. In that case, the casing must be connected to the chassis (of the vehicle) or to the hull or grounding plate (of the boat).
- In case of a boat, direct connection to the shore ground is not recommended because of potential galvanic corrosion. The solution to this is using an isolation transformer.



AC-in-1 (see fig 1)

If 120VAC voltage is present between N1 and L1-1, the Quattro will use this connection. Generally a generator will be connected to AC-in-1.

AC-in-1 must be protected by a fuse or magnetic circuit breaker rated at 60A or less, and cable cross-section must be sized accordingly. If the input AC is rated at a lower value, the fuse or magnetic circuit breaker should be down sized accordingly.

AC-in-2 (see fig 1)

If AC voltage is present between N2 and L1-2, the Quattro will use this connection, **unless voltage is also present on AC-in-1. The Quattro will then automatically select AC-in-1.** Generally the utility grid will be connected to AC-in-2.

AC-in-2 must be protected by a fuse or magnetic circuit breaker rated at 60A or less, and cable cross-section must be sized accordingly. If the input AC is rated at a lower value, the fuse or magnetic circuit breaker should be down sized accordingly.

AC-out (see fig 1)

The load is connected to these terminals. If AC voltage is available on AC-in-1 or AC-in-2, AC-out will be connected through with AC-in-1 (priority input) or AC-in-2.

The Quattro switches to inverter operation when no AC source is available. The inverter output is 120V single phase. In Invert mode, the Quattro connects both output legs (L1 and L2) together to supply 120VAC to loads on either line. The line to line voltage will be zero. Any 240VAC or 208VAC loads will therefore be supplied only when the Quattro is supplied by a split phase

120/240V or 120/208V source. This prevents heavy loads such as water heaters or 240V air conditioners from discharging the battery.

The Quattro provides seamless transfer (no-break functionality) on output L1. Output L2 connects to the inverter after a short delay.

With its PowerAssist feature the Quattro can add up to 5kVA (that is $5000 / 120 = 42A$) to L1-1 or L1-2 during periods of peak power requirement. Together with a maximum input current of 60A this means that the L1 output can supply up to $50 + 42 = 92A$.

An earth leakage circuit breaker and a fuse or circuit breaker rated to support the expected load must be included in series with output L1, and cable cross-section must be sized accordingly. The maximum rating of the fuse or circuit breaker is 100A.

The L2 output should be protected by a fuse or circuit breaker of 60A or less.

4.6 Connection options

4.6.1 Starter battery (connection terminal G, see appendix A)

The Quattro has a connection for charging a starter battery. Output current is limited to 4A.

4.6.2 Voltage sense (connection terminal E, see appendix A)

For compensating possible cable losses during charging, two sense wires can be connected to measure the voltage directly on the battery or on the positive and negative distribution points. Use wire with a cross-section of at least $0,75mm^2$.

During battery charging, the Quattro will compensate the voltage drop over the DC cables to a maximum of 1 Volt (i.e. 1V over the positive connection and 1V over the negative connection). Once the voltage drop reaches 1V, the charging current is reduced.

4.6.3 Temperature sensor (connection terminal H, see appendix A)

For temperature-compensated charging, the temperature sensor (supplied with the Quattro) can be connected. The sensor is isolated and must be fitted to the negative terminal of the battery.

4.6.4 Remote control

The Quattro can be remotely controlled in two ways:

- With an external switch (connection terminal L, see appendix A). Operates only if the switch on the Quattro is set to "on".
- With a remote control panel (connected to one of the two RJ48 sockets B, see appendix A). Operates only if the switch on the Quattro is set to "on".

Using the remote control panel, only the current limit for AC-in-2 can be set (for PowerControl and PowerAssist).

The current limit for AC-in-1 can be set with DIP switches on the control board of the Quattro or by means of software.

Only one remote control can be connected, i.e. either a switch or a remote control panel.

4.6.5. Multi functional relay

The Quattro is equipped with a multi-functional relay that by default is programmed as an alarm relay. The relay can be programmed for all kinds of other applications however, for example to start a generator (VEConfigure software needed).

4.6.6 Connecting Quattros in parallel (see appendix C)

Up to 6 Quattro's can be connected in parallel. To this end, a connection is established between the devices by means of standard RJ45 UTP cables. The **system** (one or more Quattro's plus optional control panel) will require subsequent configuration (see Section 5).

In the event of connecting Quattro units in parallel, the following requirements must be met:

- A maximum of six units connected in parallel.
- Only identical devices with the same power ratings may be connected in parallel.
- The DC connection cables to the devices must be of equal length and cross-section.
- If a positive and a negative DC distribution point is used, the cross-section of the connection between the batteries and the DC distribution point must at least equal the sum of the required cross-sections of the connections between the distribution point and the Quattro units.
- Place the Quattro units close to each other, but allow at least 10 cm / 4 inch for ventilation purposes under, above and beside the units.
- UTP cables must be connected directly from one unit to the other (and to the remote panel). Connection/splitter boxes are not permitted.
- A battery-temperature sensor need only be connected to one unit in the system. If the temperature of several batteries is to be measured, the sensors of the other Quattro units in the system can be used (with a maximum of one sensor per Quattro). Temperature compensation during battery charging responds to the sensor indicating the highest temperature.
- Voltage sensing must be connected to the master (see Section 5.5.1.4).
- If more than three units are connected in parallel in one system, a dangle is required (see Section 5).
- Only one remote control (panel or switch) can be connected to the **system**.

4.6.7 Three-phase configuration (see appendix C)

Quattro's can also be used in 3-phase configuration. To this end, a connection between the devices is made by means of standard RJ45 UTP cables (the same as for parallel operation). The **system** (Quattro's plus an optional control panel) will require subsequent configuration (see Section 5).

Pre-requisites: see Section 4.6.6.

4.6.8 Two phase (split phase) configuration (see appendix C)

Quattro's can also be used in split phase configuration. To this end, a connection between the devices is made by means of standard RJ45 UTP cables (the same as for parallel operation). The **system** (Quattro's plus an optional control panel) will require subsequent configuration (see Section 5).

Pre-requisites: see Section 4.6.6.

5. Configuration



- Settings may only be changed by a qualified electrical engineer.
- Read the instructions thoroughly before implementing changes.
- During setting of the charger, the DC fuse in the battery connections must be removed.

5.1 Standard settings: ready for use

On delivery, the Quattro is set to standard factory values. In general, these settings are selected for single-unit operation. Settings, therefore, do not require changing in the event of stand-alone use.

Warning: Possibly, the standard battery charging voltage is not suitable for your batteries! Refer to the manufacturer's documentation, or to your battery supplier!

Standard Quattro factory settings

Inverter frequency	60 Hz
Input frequency range	45 - 65 Hz
Input voltage range (neutral to L1-1, L1-2 only)	94 - 143 VAC (input voltage is monitored between neutral and L1-1, L1-2)
Inverter output voltage	120 VAC
Stand-alone / parallel / 3-phase	stand-alone
AES (Automatic Economy Switch)	off
Ground relay	on
Charger on/ off	on
Charging characteristics	four-stage adaptive with BatterySafe mode
Charging current	75% of the maximum charging current
Battery type	Victron Gel Deep Discharge (also suitable for Victron AGM Deep Discharge)
Automatic equalisation charging	off
Absorption voltage	14.4 / 28.8 / 57.6 V
Absorption time	up to 8 hours (depending on bulk time)
Float voltage	13.8 / 27.6 / 55.2 V
Storage voltage	13.2 / 26.4 / 52.8 V (not adjustable)
Repeated absorption time	1 hour
Absorption repeat interval	7 days
Bulk protection	on
Generator (AC-in-1) / shore current (AC-in-2)	50A/30A (= adjustable current limit for PowerControl and PowerAssist functions)
UPS feature	on
Dynamic current limiter	off
WeakAC	off
BoostFactor	2
Multi-functional relay	alarm function
VirtualSwitch	controls the multi-functional relay
PowerAssist	on

5.2 Explanation of settings

Settings that are not self-explanatory are described briefly below. For further information, please refer to the help files in the software configuration programs (see Section 5.3).

Inverter frequency

Output frequency if no AC is present at the input.
Adjustability: 60Hz; 50Hz

Input frequency range

Input frequency range accepted by the Quattro. The Quattro synchronises within this range with the voltage present on L1-1 of AC-in-1 (priority input) or L1-2 of AC-in-2. Once synchronised, the output frequency will be equal to the input frequency.
Adjustability: 45 – 65 Hz; 45 – 55 Hz; 55 – 65 Hz

Input voltage range

Voltage range accepted by the Quattro. The Quattro synchronises within this range with the voltage present on L1-1 of AC-in-1 (priority input) or on L1-2 of AC-in-2. After the back feed relay has closed, output voltage will be equal to input voltage.
Adjustability: Lower limit: 94 - 120V
Upper limit: 120 - 143V

Inverter voltage

Output voltage of the Quattro in battery operation.
Adjustability: 95 – 128V

Stand-alone / parallel operation / 2-3 phase setting

Using several devices, it is possible to:

- increase total inverter power (several devices in parallel)
- create a split-phase system (available only on Quattro units with 120V output voltage)
- create a 3-phase system.

To this end, the devices must be mutually connected with RJ45 UTP cables. Standard device settings, however, are such that each device operates in stand-alone operation. Reconfiguration of the devices is therefore required.



AES (Automatic Economy Switch)

If this setting is turned 'on', the power consumption in no-load operation and with low loads is decreased by approx. 20%, by slightly 'narrowing' the sinusoidal voltage. Applicable in stand-alone configuration only.
Not adjustable with DIP switches.

Search Mode

Instead of the AES mode, the **search mode** can also be chosen (with help of VEConfigure only).
If search mode is 'on', the power consumption in no-load operation is decreased by approx. 70%. In this mode the MultiPlus, when operating in inverter mode, is switched off in case of no load or very low load, and switches on every two seconds for a short period. If the output current exceeds a set level, the inverter will continue to operate. If not, the inverter will shut down again.

The Search Mode "shut down" and "remain on" load levels can be set with VEConfigure.

The factory settings are:

Shut down: 40 Watt (linear load)

Turn on: 100 Watt (linear load)

Not adjustable with DIP switches. Applicable in stand-alone configuration only.

Ground relay (see appendix B)

With this relay (H), the neutral conductor of the AC output is grounded to the casing when the back feed safety relays in the AC-in-1 and the AC-in-2 inputs are open. This ensures the correct operation of earth leakage circuit breakers in the outputs. If a non-grounded output is required during inverter operation, this function must be turned off. (See also Section 4.5)
Not adjustable with DIP switches.

IMPORTANT NOTE:

When the ground relay function is set to 'always open', -output L2 will remain disconnected from the inverter (see relay H in fig 1). This results in no power on L2-output when the Quattro is in invert mode.

Charge profile

The standard setting is 'Four-stage adaptive with BatterySafe mode'. See Section 2 for a description.
This is the recommended charge profile. See the help files in the software configuration programs for other features.
Alternatively, the 'fixed' mode can be selected with DIP switches.

Battery type

The standard setting is the most suitable for Victron Gel Deep Discharge, Gel Exide A200, and tubular plate stationary batteries (OPzS). This setting can also be used for many other batteries: e.g. Victron AGM Deep Discharge and other AGM batteries, and many types of flat-plate flooded batteries. Four charging voltages can be set with DIP switches.

Automatic equalisation charging

This setting is intended for tubular plate traction batteries. During absorption the voltage limit increases to 2,83V/cell (34V for a 24V battery) once the charge current has tapered down to less than 10% of the set maximum current.
Not adjustable with DIP switches.

See 'tubular plate traction battery charge curve' in VEConfigure.

Absorption time

This depends on the bulk time (adaptive charging characteristic), so that the battery is optimally charged. If the 'fixed' charging characteristic is selected, the absorption time is fixed. For most batteries, a maximum absorption time of eight hours is suitable. If an extra high absorption voltage is selected for rapid charging (only possible for open, flooded batteries!), four hours is preferable. With DIP switches, a time of eight or four hours can be set. For the adaptive charging characteristic, this determines the maximum absorption time.

Storage voltage, Repeated Absorption Time, Absorption Repeat Interval

See Section 2. Not adjustable with DIP switches.

Bulk Protection

When this setting is 'on', the bulk charging time is limited to 10 hours. A longer charging time could indicate a system error (e.g. a battery cell short-circuit). Not adjustable with DIP switches.

Generator (AC-in-1) / Shore current (AC-in-2)

These are the current limit settings at which PowerControl and PowerAssist come into operation.

PowerAssist setting range:

From 11A to 60A, both for input AC-in-1 and AC-in-2

Factory setting:

AC-in-1: 50A

AC-in-2: 30A

In case of parallel units the range the minimum and maximum values have to be multiplied by the number of parallel units.

See Section 2, the book 'Energy Unlimited', or the many descriptions of this unique feature on our website

www.victronenergy.com

UPS mode

If this setting is 'on' and AC on the input fails, the Quattro switches to inverter operation practically without interruption. The Quattro can then be used as an Uninterruptible Power Supply (UPS) for sensitive equipment such as computers or communication systems.

The output voltage of some generators is too unstable and distorted for using this setting – the Quattro would continually switch to inverter operation. For this reason, the setting can be turned off. The Quattro will then respond less quickly to voltage deviations on AC-in-1 or AC-in-2. The switchover time to inverter operation is consequently slightly longer, but most equipment (computers, clocks or household equipment) is not adversely impacted.

Recommendation: Turn the UPS feature off if the Quattro fails to synchronise, or continually switches back to inverter operation.

Dynamic current limiter

Intended for generators, the AC voltage being generated by means of a static inverter (so-called 'inverter' generators). In these generators, engine speed is reduced when the load is low: This reduces noise, fuel consumption and pollution. A disadvantage is that the output voltage will drop severely in the event of a sudden load increase. More load can only be supplied after the engine is up to speed.

When this setting is 'on', the Quattro will start supplying extra power at a low generator output level and gradually allow the generator to supply more, until the set current limit is reached. This allows the generator engine to get up to speed.

This setting is also often used for 'classic' generators that respond slowly to sudden load variation.

WeakAC

Strong distortion of the input voltage can result in the charger hardly operating or not operating at all. If WeakAC is set, the charger will also accept a strongly distorted voltage, at the cost of greater distortion of the input current.

Recommendation: Turn WeakAC on if the charger is hardly charging or not charging at all (which is quite rare!). Also turn on the dynamic current limiter simultaneously, and reduce the maximum charging current to prevent overloading the generator if necessary.

Not adjustable with DIP switches.

BoostFactor

Change this setting only after consulting with Victron Energy or with an engineer trained by Victron Energy!

Not adjustable with DIP switches.

Multi-functional relay

By default, the multi-functional relay is set as an alarm relay, i.e. the relay will de-energise in the event of an alarm or a pre-alarm (inverter almost too hot, ripple on the input almost too high, battery voltage almost too low). Not adjustable with DIP switches.

VirtualSwitch

The VirtualSwitch is a software function in the Quattro microprocessor. The inputs of this function are parameters that can be selected with VEConfigure (e.g. certain alarms or voltage levels). The output is binary (0 or 1). The output can be connected to a binary microprocessor output (e.g. the multi-functional relay, or the relay in one of the AC inputs).

If connected to the multi-functional relay, and with battery voltage and time as input values, for example, the VirtualSwitch can be configured to supply a generator starting signal.

If connected to an AC input relay, and with battery voltage and time as input, for example, the connected mains supply can be interrupted.

Application: **A house or an office connected to the public mains, fitted with solar panels with energy storage in batteries.**

The batteries are used to prevent return delivery to the mains. During the day, redundant solar energy is stored in batteries. This energy is used in the evenings and at night. An energy shortfall is compensated by the mains. The Quattro converts the battery DC voltage to AC. The power is always less than or equal to the power consumption, so that return delivery to the mains does not occur. In the event of mains failure, the Quattro isolates the premises from the mains, which become autonomous (self-sufficient). In this way, a solar energy installation or a combined micro-scale heating and power plant can be economically used in areas with an unreliable mains supply and/or financially unfavourable energy-return conditions.

5.3 Configuration by computer

All settings can be changed by means of a computer or with a VE.Net panel (except for the multi-functional relay and the VirtualSwitch when using VE.Net).

The most common settings (including parallel and 3-phase operation) can be changed by means of DIP switches (see Section 5.5).

For changing settings with the computer, the following is required:

VEConfigureII software: can be downloaded free of charge at www.victronenergy.com.

A RJ45 UTP cable and the **MK2.2b** RS485-to-RS232 interface. If the computer has no RS232 connection, but does have USB, a **RS232-to-USB interface cable** is needed. Both are available from Victron Energy.

5.3.1 VE.Bus Quick Configure Setup

VE.Bus Quick Configure Setup is a software program with which systems with a maximum of three Multi's (parallel or three phase operation) can be configured in a simple manner. VEConfigureII forms part of this program.

The software free can be downloaded free of charge at www.victronenergy.com.

For connection to the computer, a RJ45 UTP cable and the **MK2.2b** RS485-to-RS232 interface is required.

If the computer has no RS232 connection, but does have USB, a **RS232-to-USB interface cable** is needed. Both are available from Victron Energy.

5.3.2 VE.Bus System Configurator and dongle

For configuring advanced applications and/or systems with four or more Multi's, **VE.Bus System Configurator** software must be used. The software can be downloaded free of charge at www.victronenergy.com. VEConfigureII forms part of this program. The system can be configured without a dongle, and will be fully functional during 15 minutes (as a demonstration facility). For permanent use, a dongle – available at additional charge – is required.

For connection to the computer, a RJ45 UTP cable and the **MK2.2b** RS485-to-RS232 interface is required.

If the computer has no RS232 connection, but does have USB, a **RS232-to-USB interface cable** is needed. Both are available from Victron Energy.

5.4 Configuration with a VE.Net panel

To this end, a VE.Net panel and the VE.Net to VE.Bus converter is required.

With VE.Net all parameters are accessible, with the exception of the multi-functional relay and the VirtualSwitch.

5.5 Configuration with DIP switches

Introduction

A number of settings can be changed using DIP switches (see appendix A, position M).

This is done as follows:

Turn the Quattro on, preferably unloaded and without AC voltage on the inputs. The Quattro will then operate in inverter mode.

Step 1: Setting the DIP switches for:

- the required current limitation of the AC inputs.
- limitation of the charging current.
- selection of stand-alone, parallel or 3-phase operation.

To store the settings after the required values have been set: press the 'Up' button for 2 seconds (**upper** button to the right of the DIP switches, see appendix A, position K). You can now re-use the DIP switches to apply the remaining settings (step 2).

Step 2: other settings

To store the settings after the required values have been set: press the 'Down' button for 2 seconds (**lower** button to the right of the DIP switches). You can now leave the DIP switches in the selected positions, so that the 'other settings' can always be recovered.

Remarks:

- The DIP switch functions are described in 'top to bottom' order. Since the uppermost DIP switch has the highest number (8), descriptions start with the switch numbered 8.
- In parallel mode or 3-phase mode, not all devices require all settings to be made (see section 5.5.1.4). For parallel or 3-phase mode, read the whole setting procedure and make a note of the required DIP switch settings before actually implementing them.

5.5.1 Step 1

5.5.1.2 Current limitation AC inputs (default: AC-in-1: 50A, AC-in-2: 30A)

If the current demand (Quattro load + battery charger) threatens to exceed the set current, the Quattro will first reduce its charging current (PowerControl), and subsequently supply additional power from the battery (PowerAssist), if needed.

The AC-in-1 current limit (the generator) can be set to eight different values by means of DIP switches.

The AC-in-2 current limit can be set to two different values by means of DIP switches. With a Phoenix Multi Control Panel, a variable current limit can be set for the AC-in-2 input.

AC-in-1 can be set using DIP switches ds8, ds7 and ds6 (default setting: 50A).

Procedure: set the DIP switches to the required value:

ds8	ds7	ds6	
off	off	off	= 15A (1.8kVA at 120V)
off	off	on	= 20A (2.4kVA at 120V)
off	on	off	= 25A (3.0kVA at 120V)
off	on	on	= 30A (3.6kVA at 120V)
on	off	off	= 35A (4.2kVA at 120V)
on	off	on	= 40A (4.8kVA at 120V)
on	on	off	= 50A (6.0kVA at 120V)
on	on	on	= 60A (7.2kVA at 120V)

Remark: Manufacturer-specified continuous power ratings for small generators are sometimes inclined to be rather optimistic. In that case, the current limit should be set to a much lower value than would otherwise be required on the basis of manufacturer-specified data.

AC-in-2 can be set in two steps using DIP switch ds5 (default setting: 30A).

Procedure: set ds5 to the required value:

ds5	
off	= 30A
on	= 50A

5.5.1.3 Charging current limitation (default setting 75%)

For maximum battery life, a charging current of 10% to 20% of the capacity in Ah should be applied.

Example: optimal charging current of a 24V/500Ah battery bank: 50A to 100A.

The temperature sensor supplied automatically adjusts the charging voltage to the battery temperature.

If faster charging – and a subsequent higher current – is required:

- the temperature sensor supplied should be fitted to the battery, since fast charging can lead to a considerable temperature rise of the battery bank. The charging voltage is adapted to the higher temperature (i.e. lowered) by means of the temperature sensor.
- the bulk charging time will sometimes be so short that a fixed absorption time would be more satisfactory ('fixed' absorption time, see ds5, step 2).

Procedure

The battery charging current can be set in four steps, using DIP switches ds4 and ds3 (default setting: 75%).

ds4	ds3	
off	off	= 25%
off	on	= 50%
on	off	= 75%
on	on	= 100%



5.5.1.4 Stand-alone, parallel, 2-3 phase operation

DIP switches ds2 and ds1 are reserved for the selection of stand-alone, parallel, split phase or 3-phase operation

NOTE:

- When configuring a parallel or 2-3 phase system, all related devices should be interconnected using RJ45 UTP cables (see appendix C, D). All devices must be turned on. They will subsequently return an error code (see Section 7), since they have been integrated into a system and still are configured as 'stand-alone'. This error message can safely be ignored.
- Storing settings (by pressing the 'Up' button (step 1) – and later on the 'Down' button (step 2) – for 2 seconds) should be done on one device only. This device is the 'master' in a parallel system or the 'leader' (L1) in a 2-3 phase system. In a parallel system, the step-1 setting of DIP switches ds8 to ds3 need to be done on the master only. The slaves will follow the master with regard to these settings (hence the master/slave relationship). In a 2-3 phase system, a number of settings are required for the other devices, i.e. the followers (for phases L2 and if applicable L3). (The followers, therefore, do not follow the leader for all settings, hence the leader/follower terminology).
- A change in the setting 'stand-alone / parallel / 2-3 phase' is only activated after the setting has been stored (by pressing the 'UP' button for 2 seconds) **and** after all devices have been turned off and then on again. In order to start up a VE.Bus system correctly, all devices should therefore be turned off after the settings have been stored. They can then be turned on in any order. The system will not start until all devices have been turned on.
- Note that only identical devices can be integrated in one system. Any attempt to use different models in one system will fail. Such devices may possibly function correctly again only after individual reconfiguration for 'stand-alone' operation.
- The combination **ds2=on** and **ds1=on** is not used.

Stand-alone operation (see figure 1)

Step 1: Setting ds2 and ds1 for stand-alone operation

- DS-8 AC-in-1 Set as desired
- DS-7 AC-in-1 Set as desired
- DS-6 AC-in-1 Set as desired
- DS-5 AC-in-2 Set as desired
- DS-4 Charging current Set as desired
- DS-3 Charging current Set as desired
- DS-2 Stand-alone operation **off**
- DS-1 Stand-alone operation **off**

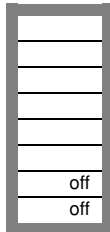

Examples of DIP switch settings for stand-alone mode are given below.

Example 1 shows the factory setting (since factory settings are entered by computer, all DIP switches of a new product are set to 'off' and are not related to the actual settings in the microprocessor).

Important: When a remote panel is connected, the AC-in-2 current limit is determined by the panel and not by the value stored in the Quattro.

Four examples of stand-alone settings:

DS-8 AC-in-1 <input type="checkbox"/> on DS-7 AC-in-1 <input type="checkbox"/> on DS-6 AC-in-1 <input type="checkbox"/> off DS-5 AC-in-2 <input type="checkbox"/> off DS-4 Charging current <input type="checkbox"/> on DS-3 Charging current <input type="checkbox"/> off DS-2 Stand-alone mode <input type="checkbox"/> off DS-1 Stand-alone mode <input type="checkbox"/> off	DS-8 <input type="checkbox"/> on DS-7 <input type="checkbox"/> on DS-6 <input type="checkbox"/> off DS-5 <input type="checkbox"/> off DS-4 <input type="checkbox"/> on DS-3 <input type="checkbox"/> on DS-2 <input type="checkbox"/> off DS-1 <input type="checkbox"/> off	DS-8 <input type="checkbox"/> off DS-7 <input type="checkbox"/> on DS-6 <input type="checkbox"/> on DS-5 <input type="checkbox"/> off DS-4 <input type="checkbox"/> on DS-3 <input type="checkbox"/> on DS-2 <input type="checkbox"/> off DS-1 <input type="checkbox"/> off	DS-8 <input type="checkbox"/> on DS-7 <input type="checkbox"/> off DS-6 <input type="checkbox"/> on DS-5 <input type="checkbox"/> on DS-4 <input type="checkbox"/> off DS-3 <input type="checkbox"/> on DS-2 <input type="checkbox"/> off DS-1 <input type="checkbox"/> off
Step1, stand-alone Example 1 (factory setting): 8, 7, 6 AC-in-1: 50A 5 AC-in-2: 30A 4, 3 Charging current: 75% 2, 1 Stand-alone mode	Step1, stand-alone Example 2: 8, 7, 6 AC-in-1: 50A 5 AC-in-2: 30A 4, 3 Charge: 100% 2, 1 Stand-alone	Step1, stand-alone Example 3: 8, 7, 6 AC-in-1: 30A 5 AC-in-2: 30A 4, 3 Charge: 100% 2, 1 Stand-alone	Step1, stand-alone Example 4: 8, 7, 6 AC-in-1: 40A 5 AC-in-2: 50A 4, 3 Charge: 50% 2, 1 Stand-alone

To store the settings after the required values have been set: press the 'Up' button for 2 seconds (**upper** button to the right of the DIP switches, see appendix A, position K). **The overload and low-battery LED's will flash to indicate acceptance of the settings.**

We recommend making a note of the settings, and filing this information in a safe place.

You can now re-use the DIP switches to apply the remaining settings (step 2).

Parallel operation (see appendix C)

Step 1: Setting ds2 and ds1 for parallel operation of two or three units

Master		Slave 1	Slave 2 (optional)
DS-8 AC-in-1	Set	DS-8 na	DS-8 na
DS-7 AC-in-1	Set	DS-7 na	DS-7 na
DS-6 AC-in-1	Set	DS-6 na	DS-6 na
DS-5 AC-in-2	Set	DS-5 na	DS-5 na
DS-4 Ch. current	Set	DS-4 na	DS-4 na
DS-3 Ch. current	Set	DS-3 na	DS-3 na
DS-2 Master	off	DS-2 Slave 1	DS-2 Slave 2
DS-1 Master	on	DS-1 Slave 1	DS-1 Slave 2

The current settings (AC current limitation and charging current) are multiplied by the number of devices. However, the AC current limitation setting when using a remote panel will always correspond to the value indicated on the panel and should **not** be multiplied by the number of devices.

Example: 15kVA parallel system

- If an AC-in-1 current limitation of 35A is set on the master and the system consists of three devices, then the effective system current limitation for AC-in-1 is equal to $3 \times 35 = 105A$ (setting for generator power $105 \times 120 = 12.6kVA$).
- If a 30A panel is connected to the master, the system current limitation for AC-in-2 is adjustable to a maximum of 30A, regardless of the number of devices.
- If the charging current on the master is set to 100% (120A for a Quattro 24/5000/120) and the system consists of three devices, then the effective system charging current is equal to $3 \times 120 = 360A$.

The settings according to this example (15kVA parallel system) are as follows:

Master		Slave 1	Slave 2
DS-8 AC-in-1 ($3 \times 35 = 105A$)	on	DS-8 na	DS-8 na
DS-7 AC-in-1 ($3 \times 35 = 105A$)	off	DS-7 na	DS-7 na
DS-6 AC-in-1 ($3 \times 35 = 105A$)	off	DS-6 na	DS-6 na
DS-5 AC-in-2 na (30A panel)		DS-5 na	DS-5 na
DS-4 Charging current $3 \times 120A$	on	DS-4 na	DS-4 na
DS-3 Charging current $3 \times 120A$	on	DS-3 na	DS-3 na
DS-2 Master	off	DS-2 Slave 1	DS-2 Slave 2
DS-1 Master	on	DS-1 Slave 1	DS-1 Slave 2

To store the settings after the required values have been set: press the 'Up' button of the **master** for 2 seconds (**upper** button to the right of the DIP switches, see appendix A, position K). **The overload and low-battery LED's will flash to indicate acceptance of the settings.**

We recommend making a note of the settings, and filing this information in a safe place.

You can now re-use the DIP switches to apply the remaining settings (step 2).

Split phase operation (see figure 2a and 2b)**Step 1: Setting ds2 and ds1 for 2-phase (= split phase) operation**

Leader (L1)		Follower (L2)	
DS-8 AC-in-1	Set	DS-8 Set	
DS-7 AC-in-1	Set	DS-7 Set	
DS-6 AC-in-1	Set	DS-6 Set	
DS-5 AC-in-2	Set	DS-5 Set	
DS-4 Ch. current	Set	DS-4 na	
DS-3 Ch. current	Set	DS-3 na	
DS-2 Leader	on	DS-2 Follower 1	off
DS-1 Leader	off	DS-1 Follower 1	off

As the table above shows, the current limits for each phase should be set separately (ds8 thru ds5). Thus, for AC-in-1 as well as AC-in-2, different current limits per phase can be selected.

If a panel is connected, the AC-in-2 current limit will equal the value set on the panel.

The maximum charging current is the same for all devices, and should be set on the leader (ds4 and ds3).

Example:

- AC-in-1 current limitation on the leader and the followers: 30A (setting for generator power $30 \times 120 \times 2 = 7\text{kVA}$).
- AC-in-2 current limitation with 30A panel.
- If the charging current on the leader is set to 100% (120A for a Quattro 24/5000/120) and the system consists of two devices, then the effective system charging current is equal to $2 \times 120 = 240\text{A}$.

The settings according to this example (15kVA 2-phase system) are as follows:

Leader (L1)		Follower (L2)	
DS-8 AC-in-1	30A	DS-8 AC-in-1 30A	off
DS-7 AC-in-1	30A	DS-7 AC-in-1 30A	on
DS-6 AC-in-1	30A	DS-6 AC-in-1 30A	on
DS-5 AC-in-2 na (30A panel)		DS-5 na	
DS-4 Ch. current	2x120A	DS-4 na	
DS-3 Ch. current	2x120A	DS-3 na	
DS-2 Leader	on	DS-2 Follower 1	off
DS-1 Leader	off	DS-1 Follower 1	off

To store the settings after the required values have been set: press the 'Up' button of the **leader** for 2 seconds (**upper** button to the right of the DIP switches, see appendix A, position K). **The overload and low-battery LED's will flash to indicate acceptance of the settings.**

We recommend making a note of the settings, and filing this information in a safe place.

You can now re-use the DIP switches to apply the remaining settings (step 2).

Three phase operation (see appendix D)
Step 1: Setting ds2 and ds1 for 3-phase operation

Leader (L1)	Follower (L2)	Follower (L3)
DS-8 AC-in-1 Set <input type="checkbox"/>	DS-8 Set <input type="checkbox"/>	DS-8 Set <input type="checkbox"/>
DS-7 AC-in-1 Set <input type="checkbox"/>	DS-7 Set <input type="checkbox"/>	DS-7 Set <input type="checkbox"/>
DS-6 AC-in-1 Set <input type="checkbox"/>	DS-6 Set <input type="checkbox"/>	DS-6 Set <input type="checkbox"/>
DS-5 AC-in-2 Set <input type="checkbox"/>	DS-5 Set <input type="checkbox"/>	DS-5 Set <input type="checkbox"/>
DS-4 Ch. current Set <input type="checkbox"/>	DS-4 na <input type="checkbox"/>	DS-4 na <input type="checkbox"/>
DS-3 Ch. current Set <input type="checkbox"/>	DS-3 na <input type="checkbox"/>	DS-3 na <input type="checkbox"/>
DS-2 Leader <input checked="" type="checkbox"/>	DS-2 Follower 1 <input type="checkbox"/>	DS-2 Follower 2 <input type="checkbox"/>
DS-1 Leader <input type="checkbox"/>	DS-1 Follower 1 <input type="checkbox"/>	DS-1 Follower 2 <input checked="" type="checkbox"/>

As the table above shows, the current limits for each phase should be set separately (ds8 thru ds5). Thus, for AC-in1 as well as AC-in-2, different current limits per phase can be selected. If a panel is connected, the AC-in-2 current limit will equal the value set on the panel for all phases. The maximum charging current is the same for all devices, and should be set on the leader (ds4 and ds3).

Example:

- AC-in-1 current limitation on the leader and the followers: 30A (setting for generator power $30 \times 120 \times 3 = 11\text{kVA}$).
- AC-in-2 current limitation with 30A panel.
- If the charging current on the leader is set to 100% (120A for a Quattro 24/5000/120) and the system consists of three devices, then the effective system charging current is equal to $3 \times 120 = 360\text{A}$.

The settings according to this example (15kVA 3-phase system) are as follows:

Leader (L1)	Follower (L2)	Follower (L3)
DS-8 AC-in-1 30A <input type="checkbox"/>	DS-8 AC-in-1 30A <input type="checkbox"/>	DS-8 AC-in-1 30A <input type="checkbox"/>
DS-7 AC-in-1 30A <input checked="" type="checkbox"/>	DS-7 AC-in-1 30A <input checked="" type="checkbox"/>	DS-7 AC-in-1 30A <input checked="" type="checkbox"/>
DS-6 AC-in-1 30A <input checked="" type="checkbox"/>	DS-6 AC-in-1 30A <input checked="" type="checkbox"/>	DS-6 AC-in-1 30A <input checked="" type="checkbox"/>
DS-5 AC-in-2 na (30A panel) <input type="checkbox"/>	DS-5 na <input type="checkbox"/>	DS-5 na <input type="checkbox"/>
DS-4 Ch. current 3x120A <input checked="" type="checkbox"/>	DS-4 na <input type="checkbox"/>	DS-4 na <input type="checkbox"/>
DS-3 Ch. current 3x120A <input checked="" type="checkbox"/>	DS-3 na <input type="checkbox"/>	DS-3 na <input type="checkbox"/>
DS-2 Leader <input checked="" type="checkbox"/>	DS-2 Follower 1 <input type="checkbox"/>	DS-2 Follower 2 <input type="checkbox"/>
DS-1 Leader <input type="checkbox"/>	DS-1 Follower 1 <input type="checkbox"/>	DS-1 Follower 2 <input checked="" type="checkbox"/>

To store the settings after the required values have been set: press the 'Up' button of the **leader** for 2 seconds (**upper** button to the right of the DIP switches, see appendix A, position K). **The overload and low-battery LED's will flash to indicate acceptance of the settings.**

We recommend making a note of the settings, and filing this information in a safe place.

You can now re-use the DIP switches to apply the remaining settings (step 2).

Important note:

Do NOT connect the L2-in and L2-out of the Quattro's when a split phase or three phase system is created this way. These systems have a different way of creating L2 which is not compatible with the L2 connections on the Quattro. Unexpected and/or unwanted behaviour will be the result when connecting the L2 terminals.

5.5.2 Step 2: Other settings

The remaining settings are not relevant for slaves.

Some of the remaining settings are not relevant for followers (**L2, L3**). These settings are imposed on the whole system by the leader **L1**. If a setting is irrelevant for **L2, L3** devices, this is mentioned explicitly.

ds8-ds7: Setting charging voltages (**not relevant for L2, L3**)

ds8-ds7	Absorption voltage	Float voltage	Storage voltage	Suitable for
off off	14.1 28.2 56.4	13.8 27.6 55.2	13.2 26.4 52.8	Gel Victron Long Life (OPzV) Gel Exide A600 (OPzV) Gel MK battery
off on	14.4 28.8 57.6	13.8 27.6 55.2	13.2 26.4 52.8	Gel Victron Deep Discharge Gel Exide A200 AGM Victron Deep Discharge Stationary tubular plate (OPzS)
on off	14.7 29.4 58.8	13.8 27.6 55.2	13.2 26.4 52.8	AGM Victron Deep Discharge Tubular plate traction or OPzS batteries in semi-float mode AGM spiral cell
on on	15.0 30.0 60.0	13.8 27.6 55.2	13.2 26.4 52.8	Tubular plate traction or OPzS batteries in cyclic mode

ds6: absorption time 8 or 4 hours **on** = 8 hours **off** = 4 hours
(**not relevant for L2, L3**)

ds5: adaptive charging characteristic **on** = active **off** = inactive (inactive = fixed absorption time)
(**not relevant for L2, L3**)

ds4: dynamic current limiter **on** = active **off** = inactive

ds3: UPS function **on** = active **off** = inactive

ds2: converter voltage **on** = 120V **off** = 115V

ds1: converter frequency **on** = 50Hz **off** = 60Hz

(**not relevant for L2, L3**)

(note: the wide input frequency range (45-65z) is 'on' by default)

Step 2: Exemplary settings for stand-alone mode

Example 1 is the factory setting (since factory settings are entered by computer, all DIP switches of a new product are always in 'off' position and are not related to the actual settings in the microprocessor).

DS-8 Ch. voltage <input type="checkbox"/> off DS-7 Ch. voltage <input checked="" type="checkbox"/> on DS-6 Absorpt. time <input checked="" type="checkbox"/> on DS-5 Adaptive ch. <input checked="" type="checkbox"/> on DS-4 Dyn. Curr. limit <input type="checkbox"/> off DS-3 UPS function: <input checked="" type="checkbox"/> on DS-2 Voltage <input checked="" type="checkbox"/> on DS-1 Frequency <input type="checkbox"/> off	DS-8 <input type="checkbox"/> off DS-7 <input type="checkbox"/> off DS-6 <input checked="" type="checkbox"/> on DS-5 <input checked="" type="checkbox"/> on DS-4 <input type="checkbox"/> off DS-3 <input type="checkbox"/> off DS-2 <input checked="" type="checkbox"/> on DS-1 <input type="checkbox"/> off	DS-8 <input checked="" type="checkbox"/> on DS-7 <input type="checkbox"/> off DS-6 <input checked="" type="checkbox"/> on DS-5 <input checked="" type="checkbox"/> on DS-4 <input checked="" type="checkbox"/> on DS-3 <input type="checkbox"/> off DS-2 <input type="checkbox"/> off DS-1 <input type="checkbox"/> off	DS-8 <input checked="" type="checkbox"/> on DS-7 <input checked="" type="checkbox"/> on DS-6 <input type="checkbox"/> off DS-5 <input type="checkbox"/> off DS-4 <input type="checkbox"/> off DS-3 <input checked="" type="checkbox"/> on DS-2 <input type="checkbox"/> off DS-1 <input checked="" type="checkbox"/> on
Step 2 Example 1 (factory setting): 8, 7 GEL 14,4V 6 Absorption time: 8 hours 5 Adaptive charging: on 4 Dynamic current limit: off 3 UPS function: on 2 Voltage: 120V 1 Frequency: 60Hz	Step 2 Example 2: 8, 7 OPzV 14,1V 6 Absorption time: 8 h 5 Adaptive charging: on 4 Dyn. current limit: off 3 UPS function: off 2 Voltage: 120V 1 Frequency: 60Hz	Step 2 Example 3: 8, 7 AGM 14,7V 6 Absorption time: 8 h 5 Adaptive charging: on 4 Dyn. current limit: on 3 UPS function: off 2 Voltage: 115V 1 Frequency: 60Hz	Step 2 Example 4: 8, 7 Tubular-plate 15V 6 Absorption time: 4 h 5 Fixed absorption time 4 Dyn. current limit: off 3 UPS function: on 2 Voltage: 115V 1 Frequency: 50Hz

To store the settings after the required values have been set: press the 'Down' button for 2 seconds (**lower** button to the right of the DIP switches). **The temperature and low-battery LEDs will flash to indicate acceptance of the settings.**

You can then leave the DIP switches in the selected positions, so that the 'other settings' can always be recovered.

Step 2: Exemplary setting for parallel mode

In this example, the master is configured according to factory settings.
The slaves do not require setting!

Master	Slave 1	Slave 2
DS-8 Ch. voltage(GEL 14,4V) <input type="checkbox"/> off	DS-8 na <input type="checkbox"/>	DS-8 na <input type="checkbox"/>
DS-7 Ch. voltage(GEL 14,4V) <input type="checkbox"/> on	DS-7 na <input type="checkbox"/>	DS-7 na <input type="checkbox"/>
DS-6 Absorption time (8 h) <input type="checkbox"/> on	DS-6 na <input type="checkbox"/>	DS-6 na <input type="checkbox"/>
DS-5 Adaptive charging (on) <input type="checkbox"/> on	DS-5 na <input type="checkbox"/>	DS-5 na <input type="checkbox"/>
DS-4 Dyn. current limit (off) <input type="checkbox"/> off	DS-4 na <input type="checkbox"/>	DS-4 na <input type="checkbox"/>
DS-3 UPS function (on) <input type="checkbox"/> on	DS-3 na <input type="checkbox"/>	DS-3 na <input type="checkbox"/>
DS-2 Voltage (120V) <input type="checkbox"/> on	DS-2 na <input type="checkbox"/>	DS-2 na <input type="checkbox"/>
DS-1 Frequency (60Hz) <input type="checkbox"/> off	DS-1 na <input type="checkbox"/>	DS-1 na <input type="checkbox"/>

To store the settings after the required values have been set: press the 'Down' button of the **master** for 2 seconds (**lower** button to the right of the DIP switches). **The temperature and low-battery LEDs will flash to indicate acceptance of the settings.**

You can then leave the DIP switches in the selected positions, so that the 'other settings' can always be recovered.

To start the system: first, turn all devices off. The system will start up as soon as all devices have been turned on.

Step 2: Exemplary setting for 2-3 phase mode

In this example the leader is configured according to factory settings.

Leader (L1)	Follower (L2)	Follower (L3) (for 3-phase operation only)
DS-8 Ch. Volt. GEL 14,4V <input type="checkbox"/> off	DS-8 na <input type="checkbox"/>	DS-8 na <input type="checkbox"/>
DS-7 Ch. Volt. GEL 14,4V <input type="checkbox"/> on	DS-7 na <input type="checkbox"/>	DS-7 na <input type="checkbox"/>
DS-6 Absorption time (8 h) <input type="checkbox"/> on	DS-6 na <input type="checkbox"/>	DS-6 na <input type="checkbox"/>
DS-5 Adaptive ch. (on) <input type="checkbox"/> on	DS-5 na <input type="checkbox"/>	DS-5 na <input type="checkbox"/>
DS-4 Dyn. current limit (off) <input type="checkbox"/> off	DS-4 D. c. l. (off) <input type="checkbox"/> off	DS-4 D. c. l. (off) <input type="checkbox"/> off
DS-3 UPS function (on) <input type="checkbox"/> on	DS-3 UPS f. (on) <input type="checkbox"/> on	DS-3 UPS f. (on) <input type="checkbox"/> on
DS-2 Voltage (120V) <input type="checkbox"/> on	DS-2 V (120V) <input type="checkbox"/> on	DS-2 V (120V) <input type="checkbox"/> on
DS-1 Frequency (60Hz) <input type="checkbox"/> off	DS-1 na <input type="checkbox"/>	DS-1 na <input type="checkbox"/>

To store the settings after the required values have been set: press the 'Down' button of the **leader** for 2 seconds (**lower** button to the right of the DIP switches). **The temperature and low-battery LEDs will flash to indicate acceptance of the settings.**

You can then leave the DIP switches in the selected positions, so that the 'other settings' can always be recovered.

To start the system: first, turn all devices off. The system will start up as soon as all devices have been turned on.

6. Maintenance

The Quattro does not require specific maintenance. It will suffice to check all connections once a year. Avoid moisture and oil/soot/vapours, and keep the device clean.

7. Error indications

With the procedures below, most errors can be quickly identified. If an error cannot be resolved, please refer to your Victron supplier.

7.1 General error indications

Problem	Cause	Solution
No output voltage on AC-out-2.	Quattro in inverter mode Defective fuse F3 (see appendix A).	Remove overload or short circuit on AC-out-2 and replace fuse F3 (16A).
Quattro will not switch over to generator or mains operation.	Circuit breaker or fuse in the AC-in input is open as a result of overload.	Remove overload or short circuit and reset breaker or replace fuse
Inverter operation not initiated when switched on.	The battery voltage is excessively high or too low. No voltage on DC connection.	Ensure that the battery voltage is within the correct range.
"Low battery" LED flashes.	The battery voltage is low.	Charge the battery or check the battery connections.
"Low battery" LED lights.	The converter switches off because the battery voltage is too low.	Charge the battery or check the battery connections.
"Overload" LED flashes.	The converter load is higher than the nominal load.	Reduce the load.
"Overload" LED lights.	The converter is switched off due to excessively high load.	Reduce the load.
"Temperature" LED flashes or lights.	The environmental temperature is high, or the load is too high.	Install the converter in cool and well-ventilated environment, or reduce the load.
"Low battery" and "overload" LEDs flash intermittently.	Low battery voltage and excessively high load.	Charge the batteries, disconnect or reduce the load, or install higher capacity batteries. Fit shorter and/or thicker battery cables.
"Low battery" and "overload" LEDs flash simultaneously.	Ripple voltage on the DC connection exceeds 1,5Vrms.	Check the battery cables and battery connections. Check whether battery capacity is sufficiently high, and increase this if necessary.
"Low battery" and "overload" LEDs light.	The inverter is switched off due to an excessively high ripple voltage on the input.	Install batteries with a larger capacity. Fit shorter and/or thicker battery cables, and reset the inverter (switch off, and then on again).
One alarm LED lights and the second flashes.	The inverter is switched off due to alarm activation by the lighted LED. The flashing LED indicates that the inverter was about to switch off due to the related alarm.	Check this table for appropriate measures in regard to this alarm state.
The charger does not operate.	The AC input voltage or frequency is not within the range set.	Ensure that the AC input is between 185 VAC and 265 VAC, and that the frequency is within the range set (default setting 45-65Hz).
	Circuit breaker or fuse in the AC-in input is open as a result of overload.	Remove overload or short circuit and reset breaker or replace fuse
	The battery fuse has blown.	Replace the battery fuse.
The battery is not completely charged.	The distortion or the AC input voltage is too large (generally generator supply).	Turn the settings WeakAC and dynamic current limiter on.
	Charging current excessively high, causing premature absorption phase.	Set the charging current to a level between 0.1 and 0.2 times the battery capacity.
	Poor battery connection.	Check the battery connections.
	The absorption voltage has been set to an incorrect level (too low).	Set the absorption voltage to the correct level.
	The float voltage has been set to an incorrect level (too low).	Set the float voltage to the correct level.
The battery is overcharged.	The available charging time is too short to fully charge the battery.	Select a longer charging time or higher charging current.
	The absorption time is too short. For adaptive charging this can be caused by an extremely high charging current with respect to battery capacity, so that bulk time is insufficient.	Reduce the charging current or select the 'fixed' charging characteristics.
The battery is overcharged.	The absorption voltage is set to an incorrect level (too high).	Set the absorption voltage to the correct level.
	The float voltage is set to an incorrect level (too high).	Set the float voltage to the correct level.
	Poor battery condition.	Replace the battery.
	The battery temperature is too high (due to poor ventilation, excessively high environmental temperature, or excessively high charging current).	Improve ventilation, install batteries in a cooler environment, reduce the charging current, and connect the temperature sensor.
The charging current drops to 0 as soon as the absorption phase initiates.	The battery is over-heated (>50°C)	<ul style="list-style-type: none"> — Install the battery in a cooler environment — Reduce the charging current — Check whether one of the battery cells has an internal short circuit
	Defective battery temperature sensor	Disconnect the temperature sensor plug in the Quattro. If charging functions correctly after approximately 1 minute, the temperature sensor should be replaced.

7.2 Special LED indications

(for the normal LED indications, see section 3.4)

Bulk and absorption LEDs flash synchronously (simultaneously).	Voltage sense error. The voltage measured at the voltage sense connection deviates too much (more than 7V) from the voltage on the positive and negative connection of the device. There is probably a connection error. The device will remain in normal operation. NOTE: If the "inverter on" LED flashes in phase opposition, this is a VE.Bus error code (see further on).
Absorption and float LEDs flash synchronously (simultaneously).	The battery temperature as measured has an extremely unlikely value. The sensor is probably defective or has been incorrectly connected. The device will remain in normal operation. NOTE: If the "inverter on" LED flashes in phase opposition, this a VE.Bus error code (see further on).
"Mains on" flashes and there is no output voltage.	The device is in "charger only" operation and mains supply is present. The device rejects the mains supply or is still synchronising.

7.3 VE.Bus LED indications

Equipment included in a VE.Bus system (a parallel or 3-phase arrangement) can provide so-called VE.Bus LED indications. These LED indications can be subdivided into two groups: OK codes and error codes.

7.3.1 VE.Bus OK codes

If the internal status of a device is in order but the device cannot yet be started because one or more other devices in the system indicate an error status, the devices that are in order will indicate an OK code. This facilitates error tracing in a VE.Bus system, since devices not requiring attention are easily identified as such.

Important: OK codes will only be displayed if a device is not in inverter or charging operation!

For a Quattro/Quattro:

- A flashing "bulk" LED indicates that the device can perform inverter operation.
- A flashing "float" LED indicates that the device can perform charging operation.

For an inverter:

- The "inverter on" LED must flash.
- A flashing "overload" LED indicates that the device can perform inverter operation.
- A flashing "temperature" LED indicates that the device is not blocking charging operation.

NOTE: In principle, all other LEDs must be off. If this is not the case, the code is not an OK code. However, the following exceptions apply:

- The special LED indications above can occur together with the OK codes.
- The "low battery" LED can function together with the OK code that indicates that the device can charge.

7.3.2 VE.Bus error codes

A VE.Bus system can display various error codes. These codes are displayed with the "inverter on", "bulk", "absorption" and "float" LEDs.

To interpret a VE.Bus error code correctly, the following procedure should be followed:

1. Is the "inverter on" LED flashing? If not, then there is **no** VE.Bus error code.
2. If one or more of the LEDs "bulk", "absorption" or "float" flashes, then this flash must be in phase opposition to the "inverter on" LED, i.e. the flashing LEDs are off if the "inverter on" LED is on, and vice versa. If this is not the case, then there is **no** VE.Bus error code.
3. Check the "bulk" LED, and determine which of the three tables below should be used.
4. Select the correct column and row (depending on the "absorption" and "float" LEDs), and determine the error code.
5. Determine the meaning of the code in the table below.

		Bulk LED off			Bulk LED flashes			Bulk LED on		
		Absorption LED			Absorption LED			Absorption LED		
		off	flash ing	on	off	flash ing	on	off	flash ing	on
Float LED	off	0	3	6	9	12	15	18	21	24
	flash ing	1	4	7	10	13	16	19	22	25
	on	2	5	8	11	14	17	20	23	26

Code	Meaning:	Cause/solution:
1	Device is switched off because one of the other phases in the system has switched off.	Check the failing phase.
3	Not all, or more than, the expected devices were found in the system.	The system is not properly configured. Reconfigure the system. Communication cable error. Check the cables and switch all equipment off, and then on again.
4	No other device whatsoever detected.	Check the communication cables.
5	Overvoltage on AC-out.	Check the AC cables.
10	System time synchronisation problem occurred.	Should not occur in correctly installed equipment. Check the communication cables.
14	Device cannot transmit data.	Check the communication cables (there may be a short circuit).
16	System is switched off because it is a so-called extended system and a 'dongle' is not connected.	Connect dongle.
17	One of the devices has assumed 'master' status because the original master failed.	Check the failing unit. Check the communication cables.
18	Overvoltage has occurred.	Check AC cables.
22	This device cannot function as 'slave'.	This device is an obsolete and unsuitable model. It should be replaced.
24	Switch-over system protection initiated.	Should not occur in correctly installed equipment. Switch all equipment off, and then on again. If the problem recurs, check the installation.
25	Firmware incompatibility. The firmware of one the connected devices is not sufficiently up to date to operate in conjunction with this device.	1) Switch all equipment off. 2) Switch the device returning this error message on. 3) Switch on all other devices one by one until the error message reoccurs. 4) Update the firmware in the last device that was switched on.
26	Internal error.	Should not occur. Switch all equipment off, and then on again. Contact Victron Energy if the problem persists.

8. Technical specifications

Quattro	12/5000/200 120/240V	24/5000/120 120/240V	48/5000/70 120/240V
PowerControl / PowerAssist	Yes	Yes	Yes
Integrated Transfer switch	Yes	Yes	Yes
AC inputs (2x)	Input voltage: 120 V or 120/240 V Input frequency: 45 – 65 Hz Power factor: 1		
Maximum feed through current	120V single phase: 60 A 120V dual in phase: 60 A total 120/240 V split phase: 60 A each leg		
Minimum PowerAssist current	11A (AC-in-1 only)		
INVERTER			
Input voltage range (V DC)	9,5 – 17	19 – 33	38 – 66
Output (pure sinewave)	Output voltage: 120 VAC ± 2% Frequency: 60 Hz ± 0,1% (1)		
Cont. output power at 77°F/25°C (VA) (5)	5000	5000	5000
Cont. output power at 77°F/25°C (W)	4000	4250	4250
Cont. output power at 100°F/40°C (W)	3000	3350	3350
Peak power (W)	8000	10.000	10.000
Maximum efficiency (%)	92	94	95
Zero-load power (W)	25	30	30
Load shedding	All 240V loads are switched off when in inverter mode		
CHARGER			
Charge voltage 'absorption' (V DC)	14,4	28,8	57,6
Charge voltage 'float' (V DC)	13,8	27,6	55,2
Storage mode (V DC)	13,2	26,4	52,8
Charge current house battery (A) (4)	200	120	70
Charge current starter battery (A)	4		
Battery temperature sensor	Yes		
GENERAL			
Multi purpose relay (6)	Yes	Yes	Yes
Protection (2)	a – g		
Common Characteristics	Operating temp.: 0 to 120°F (-20 to +50°C) Humidity (non condensing) : max 95%		
ENCLOSURE			
Common Characteristics	Material & Colour: aluminium (blue RAL 5012) Protection category: IP 21		
Battery-connection	Four M8 bolts (2 plus and 2 minus connections)		
120/240 V AC-connection	Screw terminals 13mm ² (6 AWG)		
Weight	66 lb 30 kg		
Dimensions (hxxwxd)	17,5 x 13,0 x 9,6 inch 444 x 328 x 240 mm		
STANDARDS			
Safety	EN 60335-1, EN 60335-2-29		
Emission / Immunity	EN55014-1, EN 61000-3-2 / EN 55014-2, EN 61000-3-3		

1) Can be adjusted to 50 Hz

2) Protection

- a. Output short circuit
- b. Overload
- c. Battery voltage too high
- d. Battery voltage too low
- e. Temperature too high
- f. Input voltage ripple too high
- g. 120VAC on inverter output

3) Non linear load, crest factor 3:1

4) At 80°F / 25°C ambient

5) Multipurpose relay which can be set for general alarm, DC under voltage or genset start signal function

APPENDIX A: Connection overview

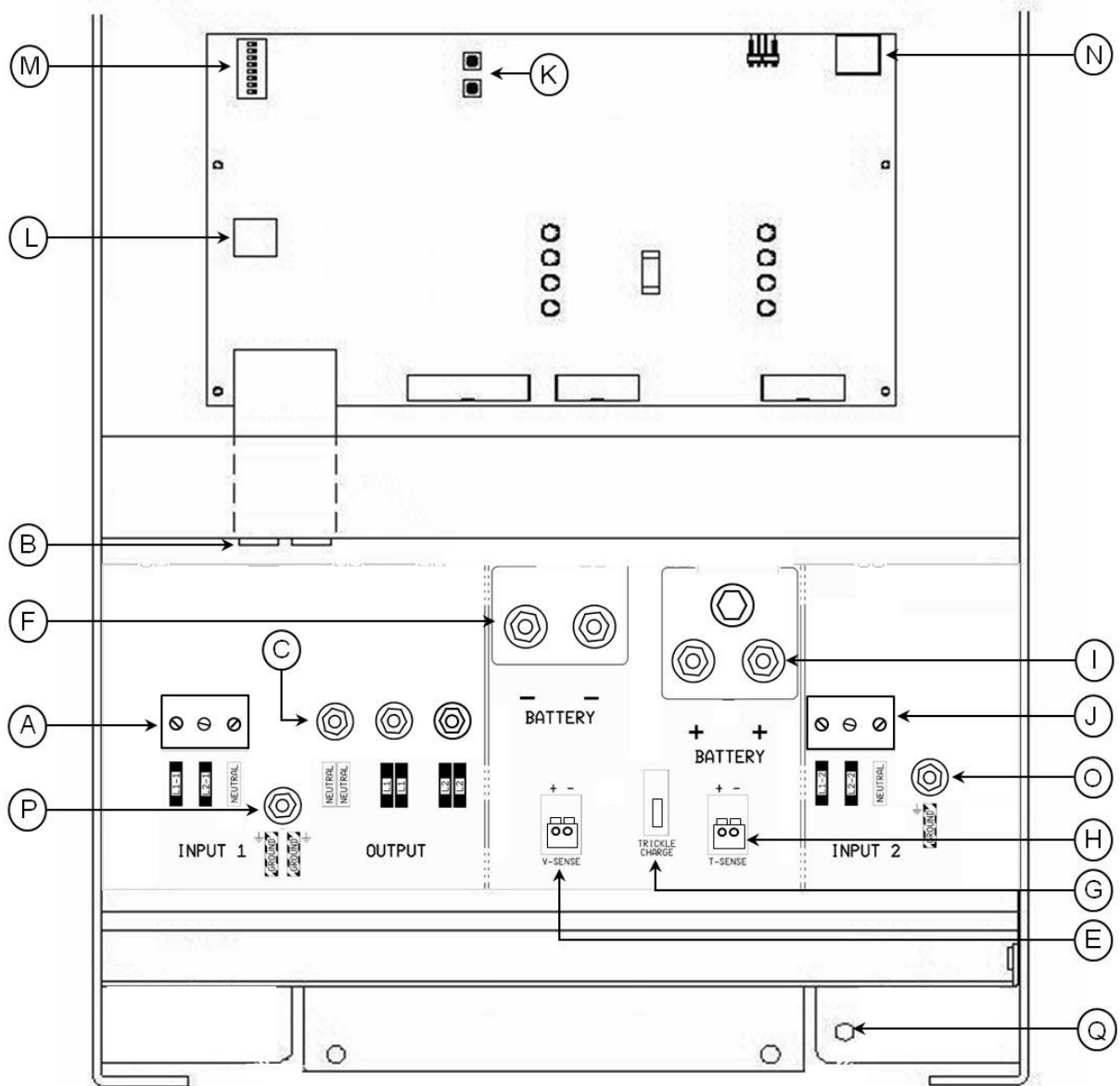

APPENDIX A: Connection overview

A	AC input (generator input) AC IN-1. Left to right: L1 (phase1), L2 (phase2), N (neutral).
B	2x RJ45 connector for remote panel and/or parallel and 3-phase operation.
C	AC output M6. Left to right: N (neutral), L1 (phase1), L2 (phase2),
E	Terminals for (left to right): Voltage sense positive +, Voltage sense minus -
F	Double M8 battery minus connection.
G	Starter battery positive. (<i>starter battery minus: use battery minus cable for connection</i>).
H	Terminals for (left to right): temperature sensor positive, temperature sensor minus.
I	Double M8 battery positive connection.
J	AC input (shore/grid supply) AC IN-2. Left to right: L1 (phase1), L2 (phase2), N (neutral).
K	Pushbuttons for set-up mode
L	Connector for remote switch: Short left and middle terminal to switch "on". Short right and middle terminal to switch to "charger only".
M	DIP switches for set-up mode.
N	Alarm contact: Left to right: NC, NO, COM.
O	AC IN-2 M6 common earth connection (ground).
P	AC IN-1 and AC OUT M6 earth connection (ground).
Q	Primary ground connection M8 (PE).



APPENDIX B: Block diagram

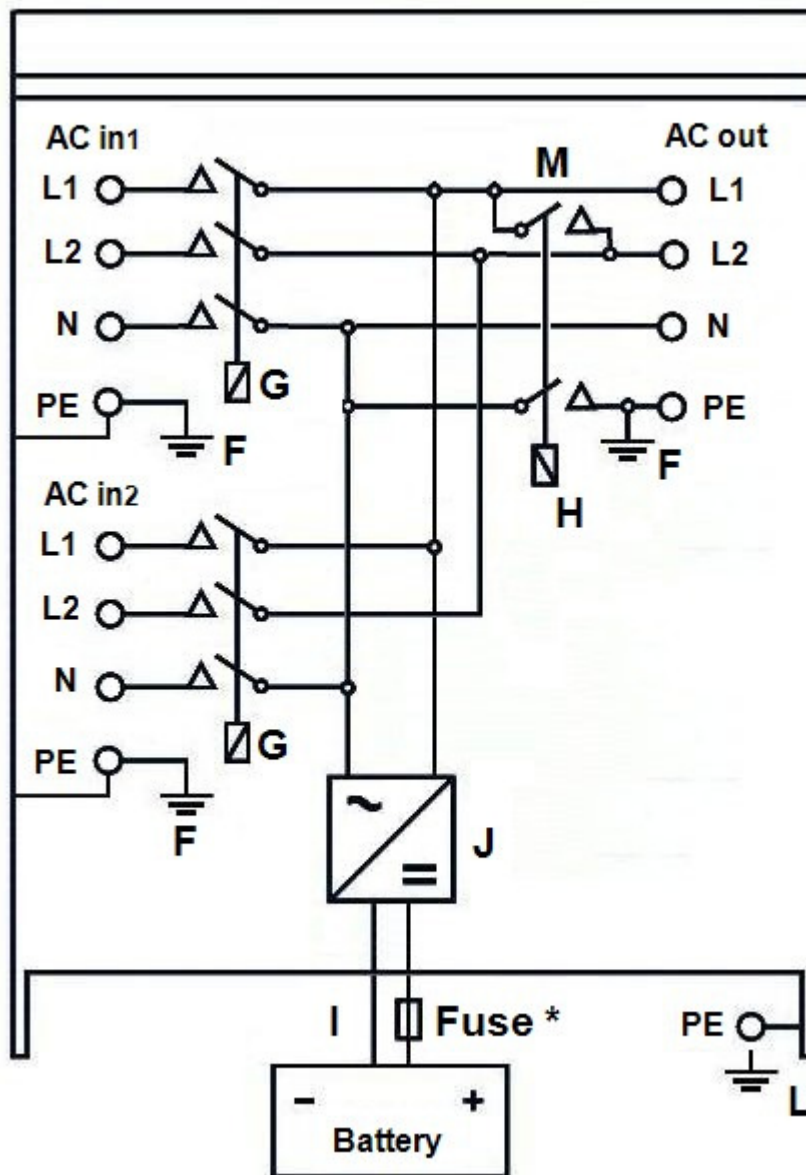

	Isolation transformer (recommended on boats) on AC input.
	Install a GFCI (ground fault circuit interrupter) on AC output.
F	Ground in and output connected to chassis.
G	Back feed safety relay.
H	Ground relay (closed when back feed is open)
I	Always install a DC fuse. * See table in chapter 4.4: "Recommended DC fuse"
J	Bidirectional converter.
L	Chassis always connected to ground.
M	Connects output L2 to output L1 when Ground relay H is closed

APPENDIX C: Parallel connection

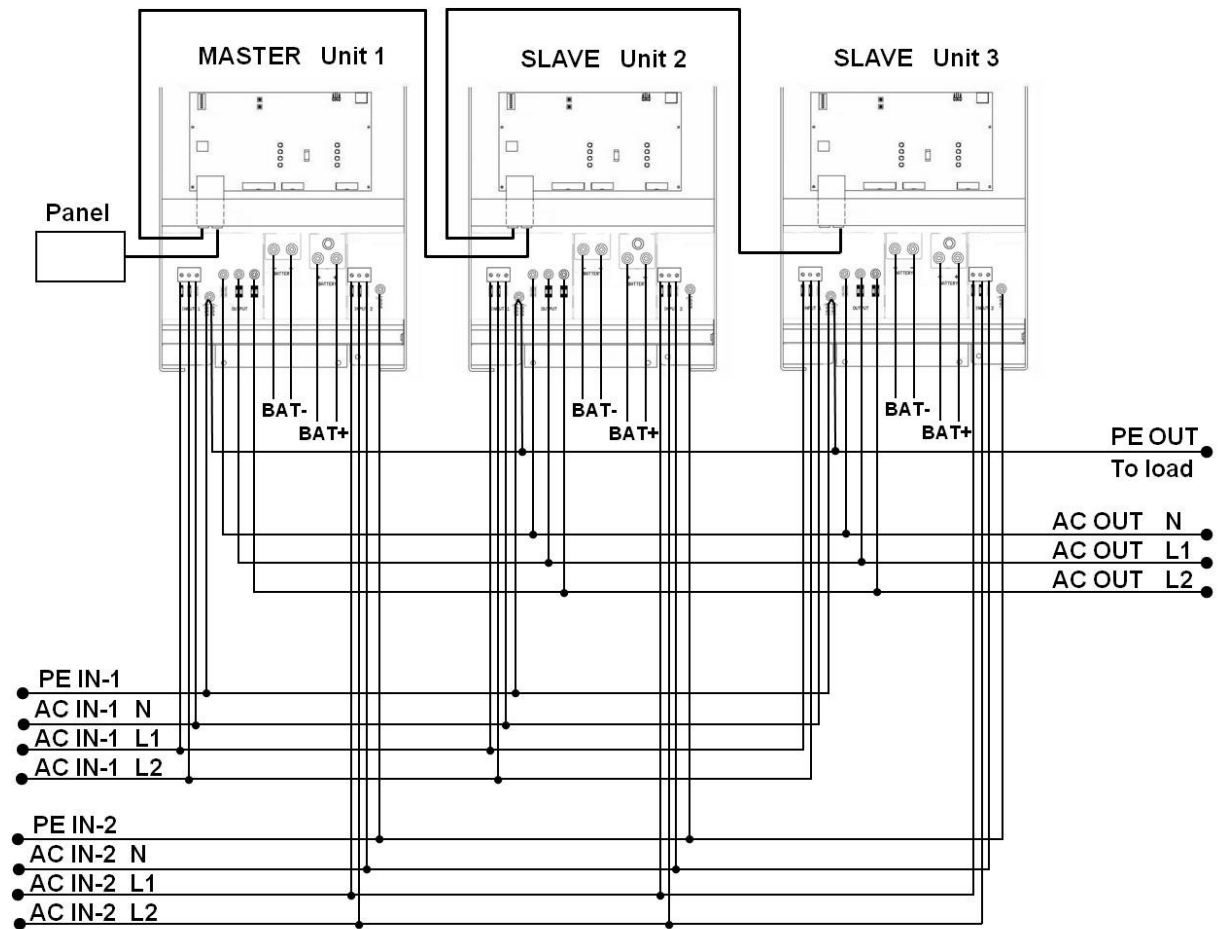

APPENDIX D: Three-phase connection

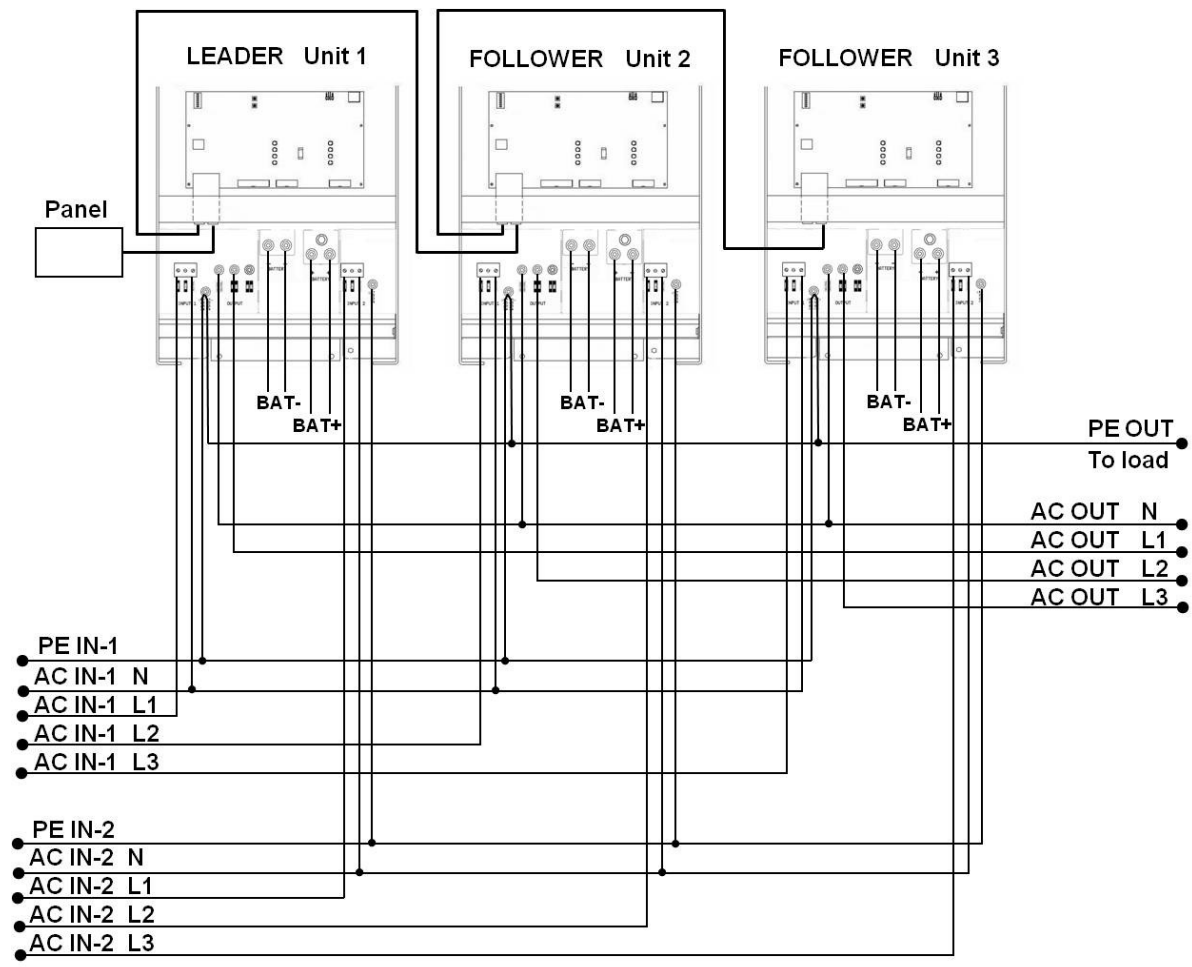

APPENDIX E: Charge characteristics

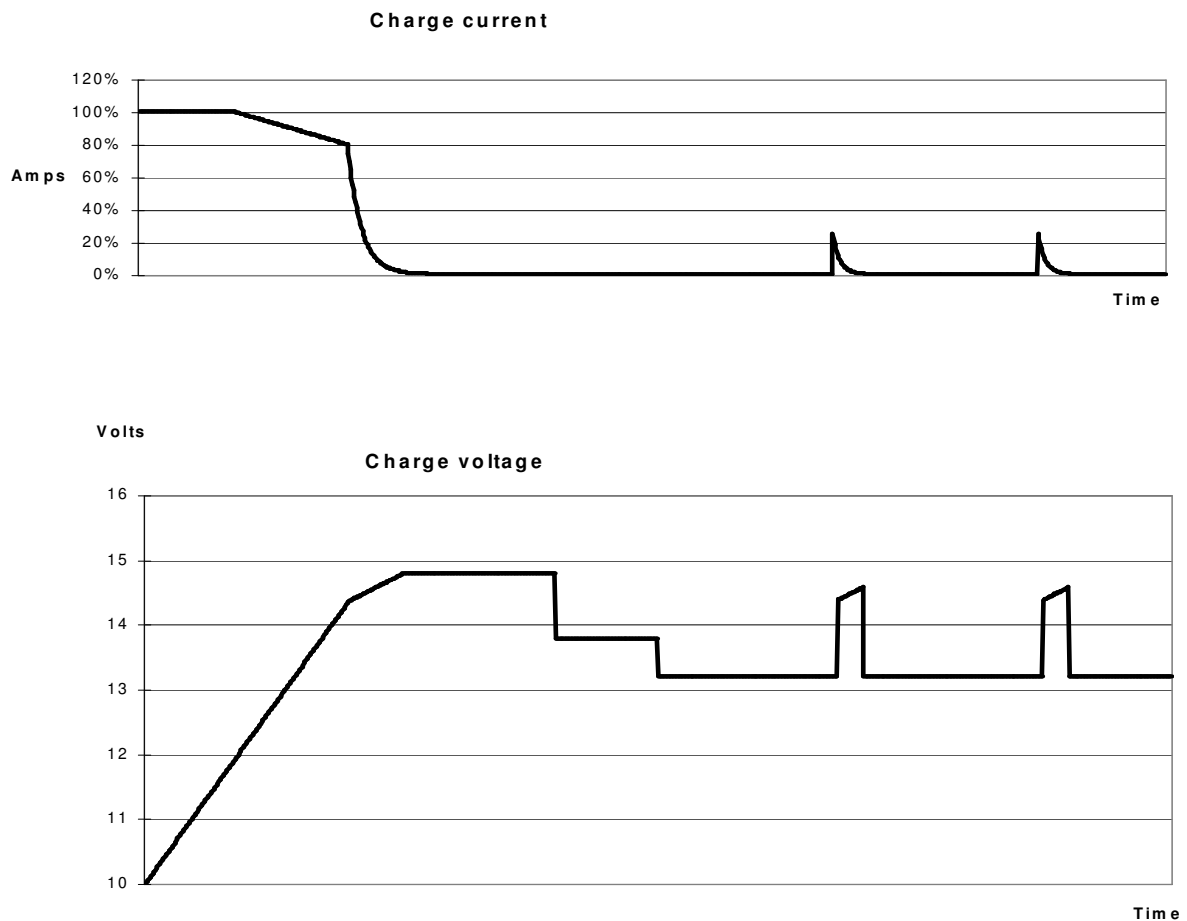

4-stage charging:

Bulk

Entered when charger is started. Constant current is applied until nominal battery voltage is reached, depending on temperature and input voltage, after which constant power is applied up to the point where excessive gassing is starting (14.4V resp. 28.8V, temperature-compensated).

Battery Safe

The applied voltage to the battery is raised gradually until the set Absorption voltage is reached. The Battery Safe Mode is part of the calculated absorption time.

Absorption

The absorption period is dependent on the bulk period. The maximum absorption time is the set Maximum Absorption time.

Float

Float voltage is applied to keep the battery fully charged

Storage

After one day of float charge the output voltage is reduced to storage level. This is 13,2V resp. 26,4V (for 12V and 24V charger). This will limit water loss to a minimum when the battery is stored for the winter season.

After an adjustable time (default = 7 days) the charger will enter Repeated Absorption mode for an adjustable time (default = one hour) to 'refresh' the battery.

APPENDIX F: Temperature compensation

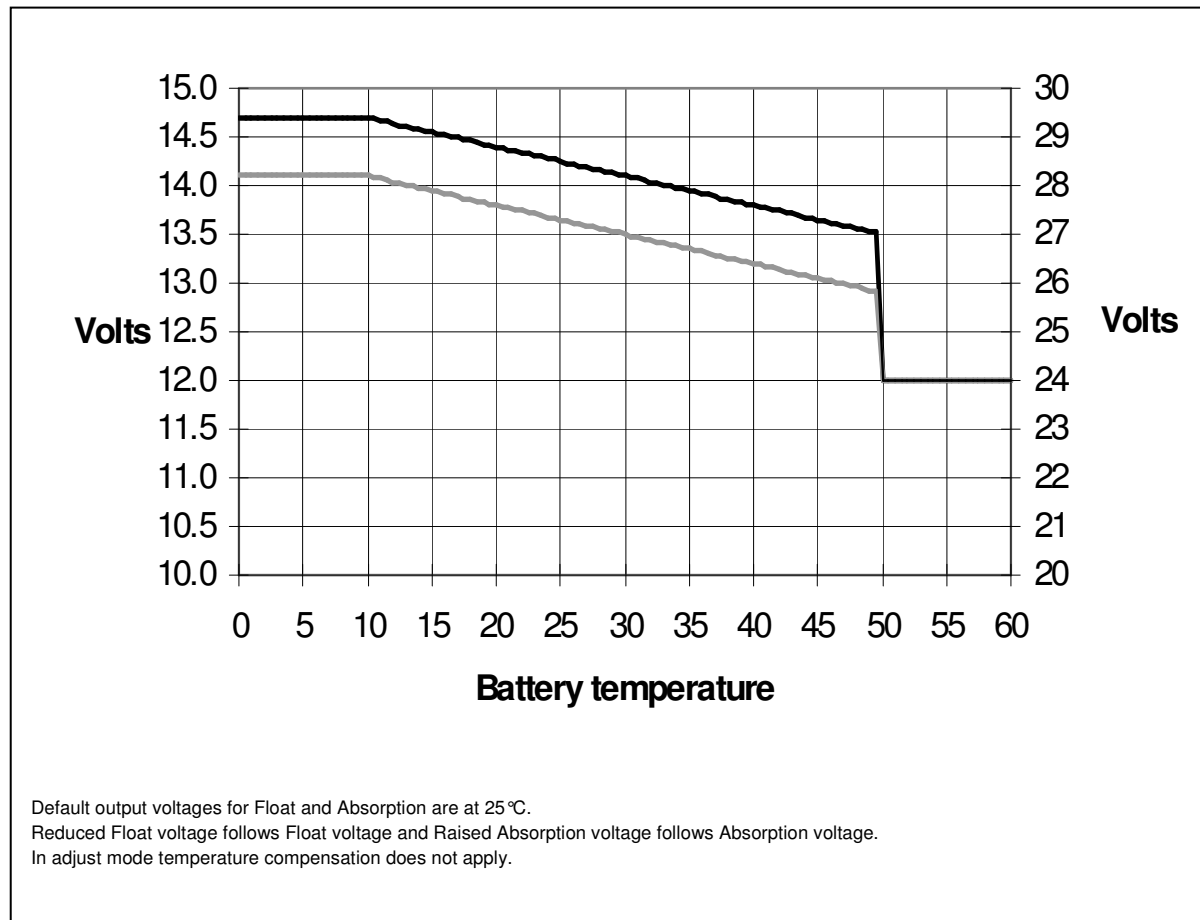

APPENDIX G: Dimensions

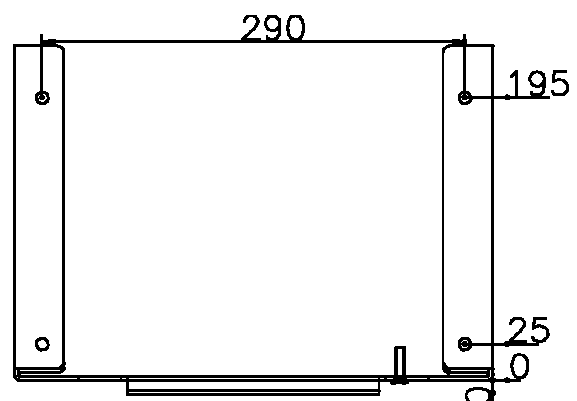
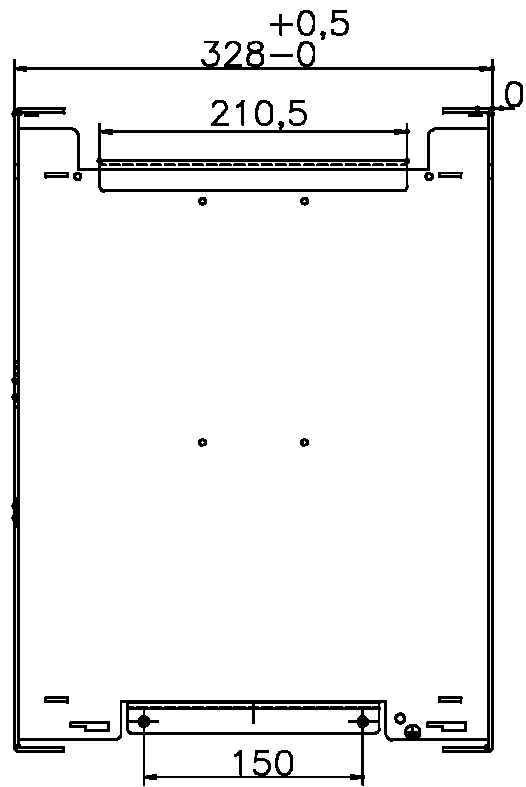
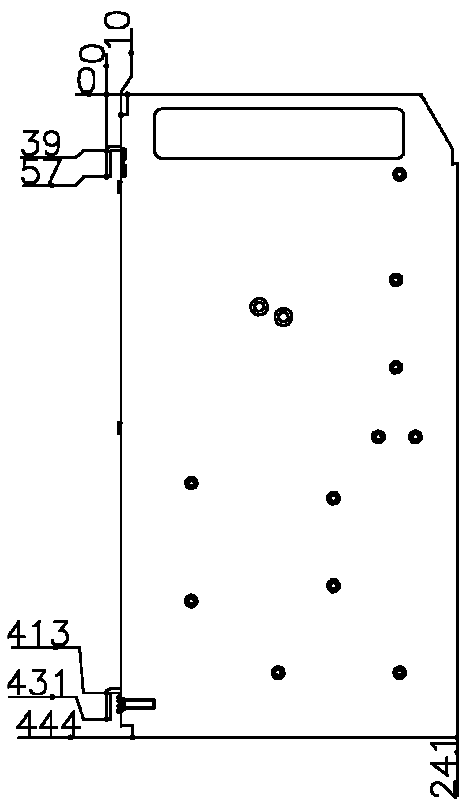
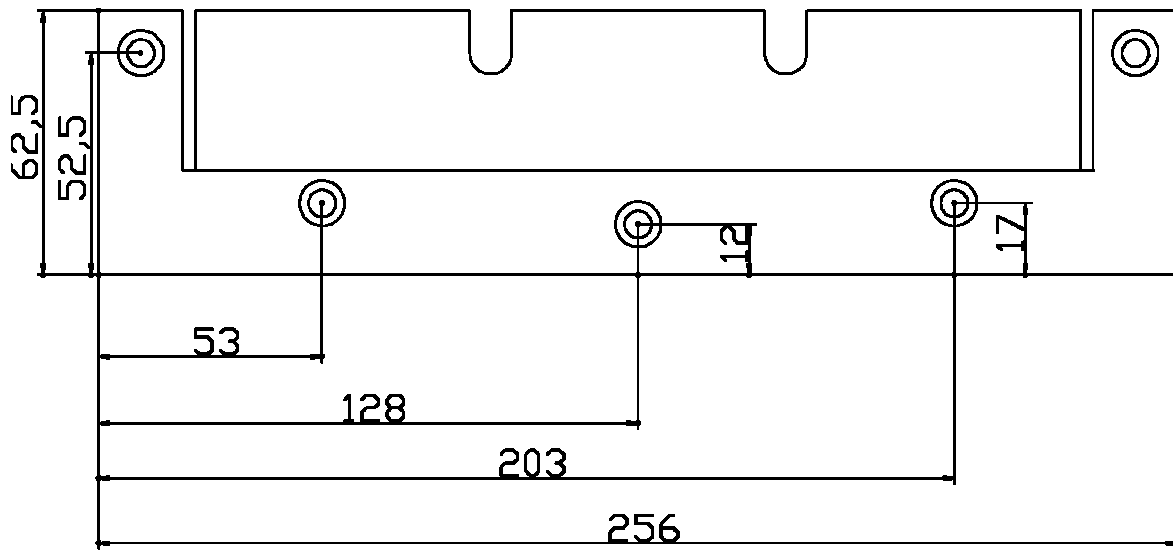

Victron Energy Blue Power

Distributor:

Serial number:

Version : 02
Date : 28 March 2011

Victron Energy B.V.
De Paal 35 | 1351 JG Almere
PO Box 50016 | 1305 AA Almere | The Netherlands

General phone : +31 (0)36 535 97 00
Customer support desk : +31 (0)36 535 97 03
Fax : +31 (0)36 535 97 40

E-mail : sales@victronenergy.com

www.victronenergy.com