

Manual

EN

Appendix

MultiPlus

12 | 3000 | 120 – 50 | 120V

24 | 3000 | 70 – 50 | 120V

Copyrights © 2007 Victron Energy B.V.
All Rights Reserved

This publication or parts thereof may not be reproduced in any form, by any method, for any purpose.

For conditions of use and permission to use this manual for publication in other than the English language, contact Victron Energy B.V.

VICTRON ENERGY B.V. MAKES NO WARRANTY, EITHER EXPRESSED OR IMPLIED, INCLUDING BUT NOT LIMITED TO ANY IMPLIED WARRANTIES OF MERCHANTABILITY OR FITNESS FOR A PARTICULAR PURPOSE, REGARDING THESE VICTRON ENERGY PRODUCTS AND MAKES SUCH VICTRON ENERGY PRODUCTS AVAILABLE SOLELY ON AN "AS IS" BASIS.

IN NO EVENT SHALL VICTRON ENERGY B.V. BE LIABLE TO ANYONE FOR SPECIAL, COLLATERAL, INCIDENTAL, OR CONSEQUENTIAL DAMAGES IN CONNECTION WITH OR ARISING OUT OF PURCHASE OR USE OF THESE VICTRON ENERGY PRODUCTS. THE SOLE AND EXCLUSIVE LIABILITY TO VICTRON ENERGY B.V., REGARDLESS OF THE FORM OF ACTION, SHALL NOT EXCEED THE PURCHASE PRICE OF THE VICTRON ENERGY PRODUCTS DESCRIBED HERE IN.

Victron Energy B.V. reserves the right to revise and improve its products as it sees fit. This publication describes the state of this product at the time of its publication and may not reflect the product at all times in the future

1. SAFETY INSTRUCTIONS

In general

Please read the documentation supplied with this product first, so that you are familiar with the safety signs and directions before using the product. This product is designed and tested in accordance with international standards. The equipment should be used for the designated application only.

WARNING: DANGER OF ELECTRICAL SHOCK

The product is used in combination with a permanent energy source (battery). Even if the equipment is switched off, a dangerous electrical voltage can occur at the input and/or output terminals. Always switch the AC power off and disconnect the battery before performing maintenance.

The product contains no internal user-serviceable parts. Do not remove the front panel and do not put the product into operation unless all panels are fitted. All maintenance should be performed by qualified personnel.

Never use the product at sites where gas or dust explosions could occur. Refer to the specifications provided by the manufacturer of the battery to ensure that the battery is suitable for use with this product. The battery manufacturer's safety instructions should always be observed.

WARNING: do not lift heavy objects unassisted.

Installation

Read the installation instructions before commencing installation activities.

This product is a safety class I device (supplied with a ground terminal for safety purposes). **Its AC input and/or output terminals must be provided with uninterruptible grounding for safety purposes. An additional grounding point is located on the outside of the product.** If it can be assumed that the grounding protection is damaged, the product should be taken out of operation and prevented from accidentally being put into operation again; contact qualified maintenance personnel.

Ensure that the connection cables are provided with fuses and circuit breakers. Never replace a protective device by a component of a different type. Refer to the manual for the correct part.

Check before switching the device on whether the available voltage source conforms to the configuration settings of the product as described in the manual.

Ensure that the equipment is used under the correct operating conditions. Never operate it in a wet or dusty environment.

Ensure that there is always sufficient free space around the product for ventilation, and that ventilation openings are not blocked.

Install the product in a heatproof environment. Ensure therefore that there are no chemicals, plastic parts, curtains or other textiles, etc. in the immediate vicinity of the equipment.

Transport and storage

On storage or transport of the product, ensure that the mains supply and battery leads are disconnected.

No liability can be accepted for damage in transit if the equipment is not transported in its original packaging.

Store the product in a dry environment; the storage temperature should range from – 20°C to 60°C.

Refer to the battery manufacturer's manual for information on transport, storage, charging, recharging and disposal of the battery.

2. DESCRIPTION

2.1 In general

The basis of the MultiPlus is an extremely powerful sine inverter, battery charger and automatic switch in a compact casing.

The MultiPlus features the following additional, often unique characteristics:

Automatic and uninterruptible switching

In the event of a supply failure or when the generating set is switched off, the MultiPlus will switch over to inverter operation and take over the supply of the connected devices. This is done so quickly that operation of computers and other electronic devices is not disturbed (Uninterruptible Power Supply or UPS functionality). This makes the MultiPlus highly suitable as an emergency power system in industrial and telecommunication applications.

Virtually unlimited power thanks to parallel operation

Up to 6 MultiPlus units can operate in parallel. Six units 24/3000/70, for example, will provide 15kW / 18kVA output power and 420 Amps charging capacity.

Three phase and split phase capability

Three units can be configured for three-phase or split phase output. But that's not all: up to 6 sets of three units can be parallel connected to provide 45kW / 54kVA inverter power and more than 1000A charging capacity.

Split phase options

Two units can be stacked to provide 120-0-120V, and additional units can be paralleled up to a total of 6 units per phase, to supply up to 30kW / 36kVA of split phase power.

Alternatively, a split phase AC source can be obtained by connecting our autotransformer (see data sheet on www.victronenergy.com) to an 'European' inverter programmed to supply 240V / 60Hz.

PowerControl – maximum use of limited shore current

The MultiPlus can supply a huge charging current. This implies heavy loading of the shore connection or generator set. Therefore a maximum current can be set. The MultiPlus then takes other power users into account, and only uses 'surplus' current for charging purposes.

PowerAssist – Extended use of your generator and shore current: the MultiPlus “co-supply” feature

This feature takes the principle of PowerControl to a further dimension allowing the MultiPlus to supplement the capacity of the alternative source. Where peak power is so often required only for a limited period, the MultiPlus will make sure that insufficient shore or generator power is immediately compensated for by power from the battery. When the load reduces, the spare power is used to recharge the battery.

This unique feature offers a definitive solution for the 'shore current problem': electric tools, dish washers, washing machines, electric cooking etc. can all run on 16A shore current, or even less. In addition, a smaller generator can be installed.



Programmable relay

The MultiPlus is equipped with a multi-functional relay that by default is programmed as an alarm relay. The relay can be programmed for all kinds of other applications however, for example to start a generator.

Programmable with DIP switches, VE.Net panel or personal computer

The MultiPlus is supplied ready for use. Three features are available for changing certain settings if desired:

- The most important settings (including parallel operation of up to three devices and 3-phase operation) can be changed in a very simple manner, using DIP switches.
- All settings, with exception of the multi-functional relay, can be changed with a VE.Net panel.
- All settings can be changed with a PC and free of charge software, downloadable from our website www.victronenergy.com

2.2 Battery charger

Adaptive 4-stage charge characteristic: bulk – absorption – float – storage

The MultiPlus features a microprocessor controlled 'adaptive' battery management system that can be preset to suit different types of batteries. The 'adaptive' feature will automatically optimise the process relative to the way the battery is being used.

The right amount of charge: variable absorption time

When only shallow discharges occur (a yacht connected to shore power for example) the absorption time is kept short in order to prevent overcharging of the battery. After a deep discharge the absorption time is automatically increased to make sure that the battery is completely recharged.

Preventing damage due to excessive gassing: the BatterySafe mode

If, in order to quickly charge a battery, a high charge current in combination with a high absorption voltage has been chosen, the MultiPlus will prevent damage due to excessive gassing by automatically limiting the rate of voltage increase once the gassing voltage has been reached

Less maintenance and aging when the battery is not in use: the Storage mode

The storage mode kicks in whenever the battery has not been subjected to discharge during 24 hours. In the storage mode float voltage is reduced to 2,2V/cell (13,2V for 12V battery) to minimise gassing and corrosion of the positive plates. Once a week the voltage is raised back to the absorption level to 'equalize' the battery. This feature prevents stratification of the electrolyte and sulphation, a major cause of early battery failure.

Two outputs to charge 2 battery banks

The MultiPlus features two outputs, of which one can carry the full output current. The second output, limited to approximately 4 A and with a slightly lower output voltage, is intended to top up a starter battery.

To increase battery life: temperature compensation

Every MultiPlus comes with a battery temperature sensor. When connected, charge voltage will automatically decrease with increasing battery temperature. This feature is especially recommended for sealed batteries and/or when important fluctuations of battery temperature are expected.

Battery voltage sense

In order to compensate for voltage loss due to cable resistance the MultiPlus is provided with a voltage sense facility so that the battery always receives the correct charge voltage.

Learn more about batteries and battery charging

To learn more about batteries and charging batteries, please refer to our book 'Energy Unlimited' (available free of charge from Victron Energy and downloadable from www.victronenergy.com). For more information about adaptive charging please look under Technical Information on our website.

3. OPERATION

3.1 On/Off/Charger Only Switch

When switched to "on", the product is fully functional. The inverter will come into operation and the LED "inverter on" will light up.

An AC voltage connected to the "AC in" terminal will be switched through to the "AC out" terminal, if within specifications. The inverter will switch off, the "mains on" LED will light up and the charger commences charging. The "bulk", "absorption" or "float" LEDs will light up, depending on the charger mode.

If the voltage at the "AC-in" terminal is not within specifications, the inverter will switch on.

When the switch is switched to "charger only", only the battery charger of the MultiPlus will operate (if mains voltage is present). In this mode input voltage also is switched through to the "AC out" terminal.

NOTE: When only the charger function is required, ensure that the switch is switched to "charger only". This prevents the inverter from being switched on if the mains voltage is lost, thus preventing your batteries from running flat.

3.2 Remote control

Remote control is possible with a 3-way switch or with a Phoenix Multi Control panel. The Phoenix Multi Control panel has a simple rotary knob with which the maximum current of the AC input can be set: see PowerControl and PowerAssist in Section 2.

3.3 Equalisation and forced absorption

3.3.1 Equalisation

Traction batteries may require regular equalisation charging. In the equalisation mode, the MultiPlus will charge with increased voltage for one hour (1V above the absorption voltage for a 12V battery, 2V for a 24V battery). The charging current is then limited to 1/4 of the set value. The "bulk" and "absorption" LEDs flash intermittently.



Equalisation mode supplies a higher charging voltage than most DC consuming devices can cope with. These devices must be disconnected before additional charging takes place.

3.3.2 Forced absorption

Under certain circumstances, it can be desirable to charge the battery for a fixed time at absorption voltage level. In Forced Absorption mode, the MultiPlus will charge at the normal absorption voltage level during the set maximum absorption time. The "absorption" LED lights.

3.3.3 Activating equalisation or forced absorption

The MultiPlus can be put into both these states from the remote panel as well as with the front panel switch, provided that all switches (front, remote and panel) are set to "on" and no switches are set to "charger only".

In order to put the MultiPlus in this state, the procedure below should be followed.

If the switch is not in the required position after following this procedure, it can be switched over quickly once. This will not change the charging state.

NOTE: Switching from "on" to "charger only" and back, as described below, must be done quickly. The switch must be toggled such that the intermediate position is 'skipped', as it were. If the switch remains in the "off" position even for a short time, the device may be turned off. In that case, the procedure must be restarted at step 1. A certain degree of familiarisation is required when using the front switch. When using the remote panel, this is less critical.

Procedure:

1. Check whether all switches (i.e. front switch, remote switch or remote panel switch if present) are in the "on" position.
2. Activating equalisation or forced absorption is only meaningful if the normal charging cycle is completed (charger is in 'Float').
3. To activate:
 - a. Switch rapidly from "on" to "charger only" and leave the switch in this position for ½ to 2 seconds.
 - b. Switch rapidly back from "charger only" to "on" and leave the switch in this position for ½ to 2 seconds.
 - c. Switch once more rapidly from "on" to "charger only" and leave the switch in this position.
4. On the MultiPlus (and, if connected, on the MultiControl panel) the three LEDs "Bulk", "Absorption" and "Float" will now flash 5 times.
5. Subsequently, the LEDs "Bulk", "Absorption" and "Float" will each light during 2 seconds.
 - a. If the switch is set to "on" while the "Bulk" LED lights, the charger will switch to equalisation.
 - b. If the switch is set to "on" while the "Absorption" LED lights, the charger will switch to forced absorption.
 - c. If the switch is set to "on" after the three LED sequence has finished, the charger will switch to "Float".
 - d. If the switch is has not been moved, the MultiPlus will remain in 'charger only' mode and switch to "Float".



3.4 LED Indications

- LED off
- ☀ LED flashes
- LED illuminated

Inverter

Charger		inverter	
<input type="radio"/> mains on	on	<input checked="" type="radio"/> inverter on	
<input type="radio"/> Bulk	 off	<input type="radio"/> overload	
<input type="radio"/> Absorption		<input type="radio"/> low battery	
<input type="radio"/> Float	charger only	<input type="radio"/> temperature	

The inverter is on and supplies power to the load.

Charger		inverter	
<input type="radio"/> mains on	on	<input checked="" type="radio"/> inverter on	
<input type="radio"/> Bulk	 off	☀ overload	
<input type="radio"/> absorption		<input type="radio"/> low battery	
<input type="radio"/> Float	charger only	<input type="radio"/> temperature	

The nominal output of the inverter is exceeded. The "overload" LED flashes

Charger		inverter	
<input type="radio"/> mains on	on	<input type="radio"/> inverter on	
<input type="radio"/> Bulk	 off	<input checked="" type="radio"/> overload	
<input type="radio"/> absorption		<input type="radio"/> low battery	
<input type="radio"/> Float	charger only	<input type="radio"/> temperature	

The inverter is switched off due to overload or short circuit.

Charger		inverter	
<input type="radio"/> mains on	on	<input type="radio"/> inverter on	
<input type="radio"/> Bulk	 off	<input type="radio"/> overload	
<input type="radio"/> absorption		<input checked="" type="radio"/> low battery	
<input type="radio"/> Float	charger only	<input type="radio"/> temperature	

The inverter has switched off due to low battery voltage.

Charger		inverter	
<input type="radio"/> mains on	on	<input checked="" type="radio"/> inverter on	
<input type="radio"/> Bulk	 off	<input type="radio"/> overload	
<input type="radio"/> absorption		<input checked="" type="radio"/> low battery	
<input type="radio"/> Float	charger only	<input type="radio"/> temperature	

The battery is almost fully exhausted.

Charger		inverter	
<input type="radio"/> mains on	on	<input checked="" type="radio"/> inverter on	
<input type="radio"/> Bulk	 off	<input type="radio"/> overload	
<input type="radio"/> absorption		<input type="radio"/> low battery	
<input type="radio"/> Float	charger only	<input checked="" type="radio"/> temperature	

The internal temperature is reaching a critical level.

Charger		inverter	
<input type="radio"/> mains on	on	<input type="radio"/> inverter on	
<input type="radio"/> Bulk	 off	<input type="radio"/> overload	
<input type="radio"/> absorption		<input type="radio"/> low battery	
<input type="radio"/> Float	charger only	<input checked="" type="radio"/> temperature	

The inverter has switched off due to the electronics temperature being too high.

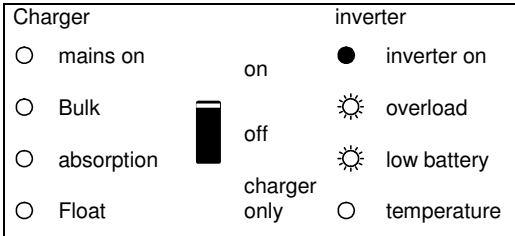

-If the LEDs are flashing alternately, the battery is nearly exhausted and the nominal output is exceeded.
 -If "overload" and "low battery" flash simultaneously, the ripple voltage on the battery terminals is too high.

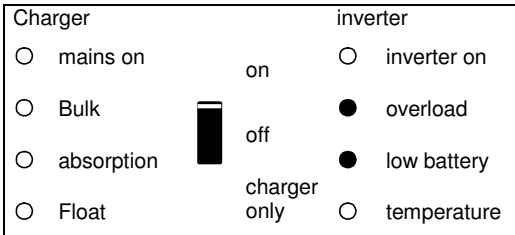

The inverter switched off due to excess ripple voltage on the battery terminals.

Battery Charger

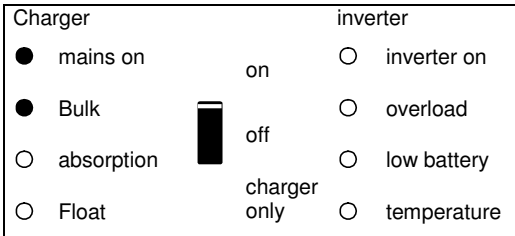

The AC input voltage is switched through and the charger operates in bulk mode.

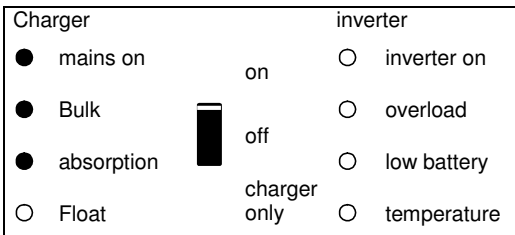

The mains voltage is switched through and the charger is on. The set absorption voltage, however, has not yet been reached. (BatterySafe mode)

Charger		inverter	
<input checked="" type="radio"/> mains on	on	<input type="radio"/> inverter on	
<input type="radio"/> Bulk	off	<input type="radio"/> overload	
<input checked="" type="radio"/> absorption	charger only	<input type="radio"/> low battery	
<input type="radio"/> Float		<input type="radio"/> temperature	

The mains voltage is switched through and the charger operates in absorption mode.

Charger		inverter	
<input checked="" type="radio"/> mains on	on	<input type="radio"/> inverter on	
<input type="radio"/> Bulk	off	<input type="radio"/> overload	
<input type="radio"/> absorption	charger only	<input type="radio"/> low battery	
<input checked="" type="radio"/> Float		<input type="radio"/> temperature	

The mains voltage is switched through and the charger operates in float mode.

Charger		inverter	
<input checked="" type="radio"/> mains on	on	<input type="radio"/> inverter on	
<input checked="" type="radio"/> Bulk	off	<input type="radio"/> overload	
<input checked="" type="radio"/> absorption	charger only	<input type="radio"/> low battery	
<input type="radio"/> Float		<input type="radio"/> temperature	

The mains voltage is switched through and the charger operates in equalize mode.

Special Indications

PowerControl

charger		inverter	
<input checked="" type="radio"/> mains on	on	<input type="radio"/> inverter on	
<input type="radio"/> bulk	off	<input type="radio"/> overload	
<input type="radio"/> absorption	charger only	<input type="radio"/> low battery	
<input type="radio"/> float		<input type="radio"/> temperature	

The AC input is switched through. The AC output current is equal to the preset maximum input current. The charge current is reduced to 0.

Power Assist

charger		inverter	
<input checked="" type="radio"/> mains on	on	<input checked="" type="radio"/> inverter on	
<input type="radio"/> bulk	off	<input type="radio"/> overload	
<input type="radio"/> absorption	charger only	<input type="radio"/> low battery	
<input type="radio"/> float		<input type="radio"/> temperature	

The AC input is switched through but the load requires more current than the preset maximum input current. The inverter is switched on to supply the required additional current.

4. Installation



This product may only be installed by a qualified electrical engineer.

4.2 Location

The product must be installed in a dry and well-ventilated area, as close as possible to the batteries. There should be a clear space of at least 10 cm (4 inch) around the appliance for cooling.



Excessively high ambient temperature will result in the following:

Reduced service life.

Reduced charging current.

Reduced peak capacity, or shutdown of the inverter.

Never position the appliance directly above the batteries.

The MultiPlus is suitable for wall mounting. For mounting purposes, a hook and two holes are provided at the back of the casing (see appendix G). The device can be fitted either horizontally or vertically. For optimal cooling, vertical fitting is preferred.



The interior of the product must remain accessible after installation.

Try and keep the distance between the product and the battery to a minimum in order to minimize cable voltage losses.



For safety purposes, this product should be installed in a heat-resistant environment. You should prevent the presence of e.g. chemicals, synthetic components, curtains or other textiles, etc., in the immediate vicinity.

4.2 Connection of battery cables

In order to utilize the full capacity of the product, batteries with sufficient capacity and battery cables with sufficient cross section should be used. See table.

	12/3000/120	24/3000/70	48/3000/35
Recommended battery capacity (Ah)	400–1200	200–700	100–400
Recommended DC fuse	400A	300A	125A
Recommended cross section (mm ²) per + and - connection terminal			
0 – 5 m	2x 50 mm ²	50 mm ²	35 mm ²
5 – 10 m	2x 70 mm ²	2x 50 mm ²	2x 35 mm ²

* '2x' means two positive and two negative cables.

Remark: Internal resistance is the important factor when working with low capacity batteries. Please consult your supplier or the relevant sections of our book "Energy Unlimited", downloadable from our website.

Procedure

Proceed as follows to connect the battery cables:



Use an insulated box spanner in order to avoid shorting the battery.
Avoid shorting the battery cables.

- Undo the four screws at the front of the enclosure and remove the front panel.
- Connect the battery cables: see Appendix A.
- Tighten the nuts well for minimal contact resistance.

4.3 Connection of the AC cabling

The MultiPlus is a safety class I product (supplied with a ground terminal for safety purposes). **Its AC input and/or output terminals and/or grounding point on the outside of the product must be provided with an uninterruptible grounding point for safety purposes.**



The MultiPlus is provided with a ground relay (relay H, see appendix B) that **automatically connects the Neutral output to the chassis if no external AC supply is available**. If an external AC supply is provided, the ground relay H will open before the input safety relay closes. This ensures the correct operation of an earth leakage circuit breaker that is connected to the output.

In a fixed installation, an uninterruptible grounding can be secured by means of the grounding wire of the AC input. Otherwise the casing must be grounded.

In a mobile installation (for example, with a shore current plug), interrupting the shore connection will simultaneously disconnect the grounding connection. In that case, the casing must be connected to the chassis (of the vehicle) or to the hull or grounding plate (of the boat).

In case of a boat, direct connection to the shore ground is not recommended because of potential galvanic corrosion. The solution to this is using an isolation transformer.

The terminal blocks can be found on the printed circuit board, see appendix A. The shore or mains cable must be connected to the MultiPlus with the aid of a three-wire cable.

- The AC input cable can be connected to the terminal block "AC-in".

The AC input must be protected by a fuse or magnetic circuit breaker rated at 50A or less, and cable cross-section must be sized accordingly. If the input AC supply is rated at a lower value, the fuse or magnetic circuit breaker should be down sized accordingly.

- The AC output cable can be connected directly to the terminal block "AC-out".

With its PowerAssist feature the MultiPlus can add up to 5kVA (that is $3000 / 120 = 25\text{A}$) to the output during periods of peak power requirement. Together with a maximum input current of 50A this means that the output can supply up to $50 + 25 = 75\text{A}$.

An earth leakage circuit breaker and a fuse or circuit breaker rated to support the expected load must be included in series with the output, and cable cross-section must be sized accordingly. The maximum rating of the fuse or circuit breaker is 75A.

4.4 Optional Connections

A number of optional connections are possible (see appendix A)

4.4.1 Second Battery

The MultiPlus has a connection for charging a starter battery.

4.4.2 Voltage Sense

Two sense wires may be connected to compensate possible battery cable losses during charging. Use wires of at least 0.75mm^2 .

4.4.3 Temperature Sensor

The temperature sensor supplied with the product may be used for temperature-compensated charging. The sensor is isolated and must be mounted on the batteries minus pole.

4.4.4 Remote Control

The product can be remotely controlled in two ways.

With an external switch. Operates only if the switch on the MultiPlus is set to "on".

With a Multi Control panel (connected to one of the two RJ48 sockets). Operates only if the switch on the MultiPlus is set to "on".

Only one remote control can be connected, i.e. either a switch or a remote control panel.

4.4.5. Programmable relay

The MultiPlus is equipped with a multi-functional relay that by default is programmed as an alarm relay. The relay can be programmed for all kinds of other applications however, for example to start a generator (VEConfigure software needed).

4.4.6 Parallel Connection

The MultiPlus can be connected in parallel with several identical devices. To this end, a connection is established between the devices by means of standard RJ45 UTP cables. The **system** (one or more MultiPlus units plus optional control panel) will require subsequent configuration (see Section 5).

In the event of connecting MultiPlus units in parallel, the following requirements must be met:

- A maximum of six units connected in parallel.
- Only identical devices may be connected in parallel.
- The DC connection cables to the devices must be of equal length and cross-section. If a positive and a negative DC distribution point is used, the cross-section of the connection between the batteries and the DC distribution point must at least equal the sum of the required cross-sections of the connections between the distribution point and the MultiPlus units.
- Place the MultiPlus units close to each other, but allow at least 10 cm / 4 inch for ventilation purposes under, above and beside the units.
- UTP cables must be connected directly from one unit to the other (and to the remote panel). Connection/splitter boxes are not permitted.
- A battery-temperature sensor need only be connected to one unit in the system. If the temperature of several batteries is to be measured, you can also connect the sensors of other MultiPlus units in the system (with a maximum of one sensor per MultiPlus). Temperature compensation during battery charging responds to the sensor indicating the highest temperature.
- Voltage sensing must be connected to the master (see Section 5.5.1.4).
- If more than three units are connected in parallel in one system, a dongle is required (see Section 5).
- Only one remote control (panel or switch) can be connected to the **system**.

4.4.7 Three-phase operation

The MultiPlus can also be used in 3-phase configuration. To this end, a connection between the devices is made by means of standard RJ45 UTP cables (the same as for parallel operation). The **system** (MultiPlus units plus an optional control panel) will require subsequently configuration (see Section 5).

Pre-requisites: see Section 4.4.6.

4.4.8 Two phase (split phase) configuration (see appendix C)

MultiPlus units can also be used in split phase configuration. To this end, a connection between the devices is made by means of standard RJ45 UTP cables (the same as for parallel operation). The **system** (MultiPlus units plus an optional control panel) will require subsequent configuration (see Section 5).

Pre-requisites: see Section 4.4.6.

5. Configuration



Settings may only be changed by a qualified electrical engineer.
Read the instructions thoroughly before implementing changes.
During setting of the charger, the AC input must be removed.

5.1 Standard settings: ready for use

On delivery, the MultiPlus is set to standard factory values. In general, these settings are suitable for single-unit operation.

Warning: Possibly, the standard battery charging voltage is not suitable for your batteries! Refer to the manufacturer's documentation, or to your battery supplier!

Standard MultiPlus factory settings

Inverter frequency	60 Hz
Input frequency range	45 - 65 Hz
Input voltage range	94 - 143 VAC
Inverter voltage	120 VAC
Stand-alone / parallel / 3-phase	stand-alone
AES (Automatic Economy Switch)	off
Ground relay	on
Charger on/ off	on
Battery charge curve	Four-stage adaptive with BatterySafe mode
Charging current	75% of the maximum charging current
Battery type	Victron Gel Deep Discharge (also suitable for Victron AGM deep discharge)
Automatic equalisation charging	off
Absorption voltage	14.4 / 28.8 / 57.6 V
Absorption time	up to 8 hours (depending on bulk time)
Float voltage	13.8 / 27.6 / 55.2 V
Storage voltage	13.2 / 26.4 / 52.8V (not adjustable)
Repeated absorption time	1 hour
Absorption repeat interval	7 days
Bulk protection	on
AC input current limit	50A (= adjustable current limit for PowerControl and PowerAssist functions)
UPS feature	on
Dynamic current limiter	off
WeakAC	off
BoostFactor	2
Multi-functional relay	alarm function
VirtualSwitch	controls the multi-functional relay
PowerAssist	on

5.2 Explanation of settings

Settings that are not self-explanatory are described briefly below. For further information, please refer to the help files in the software configuration programs (see Section 5.3).

Inverter frequency

Output frequency if no AC is present at the input.
Adjustability: 50Hz; 60Hz

Input frequency range

Input frequency range accepted by the MultiPlus. The MultiPlus synchronises within this range with the AC input frequency. The output frequency is then equal to the input frequency.
Adjustability: 45 – 65 Hz; 45 – 55 Hz; 55 – 65 Hz

Input voltage range

Voltage range accepted by the MultiPlus. The MultiPlus synchronises within this range with the AC input voltage. The output voltage is then equal to the input voltage.
Adjustability: Lower limit: 94 - 120V
Upper limit: 120 - 143V

Inverter voltage

Output voltage of the MultiPlus in battery operation.
Adjustability: 95 – 128V

Stand-alone / parallel operation / 2-3 phase setting

Using several devices, it is possible to:

- increase total inverter power (several devices in parallel)
- create a split-phase system
- create a 3-phase system.

The standard product settings are for standalone operation. For parallel, three phase or split phase operation see section 4.6.6 and 4.6.7.

AES (Automatic Economy Switch)

If this setting is turned 'on', the power consumption in no-load operation and with low loads is decreased by approx. 20%, by slightly 'narrowing' the sinusoidal voltage. Adjustable with DIP switches. Applicable in stand-alone configuration only.

Search Mode

Instead of the AES mode, the search mode can also be chosen (with help of VEConfigure only).

If search mode is 'on', the power consumption in no-load operation is decreased by approx. 70%. In this mode the MultiPlus, when operating in inverter mode, is switched off in case of no load or very low load, and switches on every two seconds for a short period. If the output current exceeds a set level, the inverter will continue to operate. If not, the inverter will shut down again.

The Search Mode "shut down" and "remain on" load levels can be set with VEConfigure.

The factory settings are:

Shut down: 40 Watt (linear load)

Turn on: 100 Watt (linear load)

Not adjustable with DIP switches. Applicable in stand-alone configuration only.

Ground relay (see appendix B)

With this relay (H), the neutral conductor of the AC output is grounded to the chassis when the back feed safety relay is open. This ensures the correct operation of earth leakage circuit breakers in the output.

In case a non-grounded output is required during inverter operation, this function can be turned off with help of VEConfigure.

Not adjustable with DIP switches.

Battery charge curve

The standard setting is 'Four-stage adaptive with BatterySafe mode'. See Section 2 for a description.

This is the recommended charge curve. See the help files in the software configuration programs for other features.

Alternatively, 'Fixed' mode can be selected with DIP switches.

Battery type

The standard setting is the most suitable for Victron Gel Deep Discharge, Gel Exide A200, and tubular plate stationary batteries (OPzS). This setting can also be used for many other batteries: e.g. Victron AGM Deep Discharge and other AGM batteries, and many types of flooded flat-plate lead-acid batteries. Four charging voltages can be set with DIP switches.

Absorption time

The absorption time depends on the bulk time (adaptive charge curve), so that the battery is optimally charged. If the 'fixed' charging characteristic is selected, the absorption time is fixed. For most batteries, a maximum absorption time of eight hours is suitable. If an extra high absorption voltage is selected for rapid charging (only possible for open, flooded batteries!), four hours is preferable. With DIP switches, a time of eight or four hours can be set. For the adaptive charge curve, this determines the maximum absorption time.

Storage voltage, Repeated Absorption Time, Absorption Repeat Interval

See Section 2. Not adjustable with DIP switches.

Bulk Protection

When this setting is 'on', the bulk charging time is limited to 10 hours. A longer charging time could indicate a system error (e.g. a battery cell short-circuit). Not adjustable with DIP switches.

AC input current limit

These are the current limit settings at which PowerControl and PowerAssist come into operation. The factory setting is 50A.

See Section 2, the book 'Energy Unlimited', or the many descriptions of this unique feature on our website www.victronenergy.com.

**Remark: lowest allowable current setting for PowerAssist: 11A.
(11A per unit in case of parallel operation)**

UPS feature

If this setting is 'on' and AC on the input fails, the MultiPlus switches to inverter operation practically without interruption. The MultiPlus can therefore be used as an Uninterruptible Power Supply (UPS) for sensitive equipment such as computers or communication systems.

The output voltage of some small generator sets is too unstable and distorted for using this setting* – the MultiPlus would continually switch to inverter operation. For this reason, the setting can be turned off. The MultiPlus will then respond less quickly to AC input voltage deviations. The switchover time to inverter operation is consequently slightly longer, but most equipment (most computers, clocks or household equipment) is not adversely impacted.

Recommendation: Turn the UPS feature off if the MultiPlus fails to synchronise, or continually switches back to inverter operation.

*In general, the UPS setting can be left 'on' if the MultiPlus is connected to a generator with a 'synchronous AVR regulated alternator'.

The UPS mode may have to be set to 'off' if the MultiPlus is connected to a generator with a 'synchronous capacitor regulated alternator' or an asynchronous alternator.

Dynamic current limiter

Intended for generators, the AC voltage being generated by means of a static inverter (so-called 'inverter' generators). In these generators, rpm is down-controlled if the load is low: this reduces noise, fuel consumption and pollution. A disadvantage is that the output voltage will drop severely or even completely fail in the event of a sudden load increase. More load can only be supplied after the engine is up to speed.

If this setting is 'on', the MultiPlus will start supplying extra power at a low generator output level and gradually allow the generator to supply more, until the set current limit is reached. This allows the generator engine to get up to speed.

This setting is also often used for 'classic' generators that respond slowly to sudden load variation.

WeakAC

Strong distortion of the input voltage can result in the charger hardly operating or not operating at all. If WeakAC is set, the charger will also accept a strongly distorted voltage, at the cost of greater distortion of the input current.

Recommendation: Turn WeakAC on if the charger is hardly charging or not charging at all (which is quite rare!). Also turn on the dynamic current limiter simultaneously, and reduce the maximum charging current to prevent overloading the generator if necessary.

Not adjustable with DIP switches.

BoostFactor

Change this setting only after consulting with Victron Energy or with an engineer trained by Victron Energy!

Not adjustable with DIP switches.

Multi-functional relay

By default, the multi-functional relay is set as an alarm relay, i.e. the relay will de-energise in the event of an alarm or a pre-alarm (inverter almost too hot, ripple on the input almost too high, battery voltage almost too low). Not adjustable with DIP switches.

VirtualSwitch

The VirtualSwitch is a software function in the MultiPlus microprocessor. The inputs of this function are parameters that can be selected with VEConfigure (e.g. certain alarms or voltage levels). The output is binary (0 or 1). The output can be connected to a binary microprocessor output (e.g. the multi-functional relay, or the relay in the AC input).

If connected to the multi-functional relay, and with battery voltage and time as input values, for example, the VirtualSwitch can be configured to supply a generator starting signal.

If connected to an AC input relay, and with battery voltage and time as input, for example, the connected mains supply can be interrupted.

Application: **A house or an office connected to the public mains, fitted with solar panels with energy storage in batteries.**

The batteries are used to prevent return delivery to the mains. During the day, redundant solar energy is stored in batteries. This energy is used in the evenings and at night. An energy shortfall is compensated by the mains. The MultiPlus converts the battery DC voltage to AC. The power is always less than or equal to the power consumption, so that return delivery to the mains does not occur. In the event of mains failure, the MultiPlus isolates the premises from the mains, which become autonomous (self-sufficient). In this way, a solar energy installation or a combined micro-scale heating and power plant can be economically used in areas with an unreliable mains supply and/or financially unfavourable energy-return conditions.

5.3 Configuration by computer

All settings can be changed by means of a computer or with a VE.Net panel (except for the multi-functional relay and the VirtualSwitch when using VE.Net).

The most common settings (including parallel and 3-phase operation) can be changed by means of DIP switches (see Section 5.5).

For changing settings with the computer, the following is required:

- VEConfigureII software: can be downloaded free of charge at www.victronenergy.com.
- A RJ45 UTP cable and the MK2.2b RS485-to-RS232 interface. If the computer has no RS232 connection, but does have USB, a RS232-to-USB interface cable is needed. Both are available from Victron Energy.

5.3.1 VE.Bus Quick Configure Setup

VE.Bus Quick Configure Setup is a software program with which systems with a maximum of three MultiPlus units (parallel or three phase operation) can be configured in a simple manner. VEConfigureII forms part of this program.

The software free can be downloaded free of charge at www.victronenergy.com.

For connection to the computer, a RJ45 UTP cable and the **MK2.2b** RS485-to-RS232 interface is required.

If the computer has no RS232 connection, but does have USB, a **RS232-to-USB interface cable** is needed. Both are available from Victron Energy.

5.3.2 VE.Bus System Configurator and dongle

For configuring advanced applications and/or systems with four or more MultiPlus units, **VE.Bus System Configurator** software must be used. The software can be downloaded free of charge at www.victronenergy.com. VEConfigureII forms part of this program.

The system can be configured without a dongle, and will be fully functional during 15 minutes (as a demonstration facility). For permanent use, a dongle – available at additional charge – is required.

For connection to the computer, a RJ45 UTP cable and the **MK2.2b** RS485-to-RS232 interface is required.

If the computer has no RS232 connection, but does have USB, a **RS232-to-USB interface cable** is needed. Both are available from Victron Energy.

5.4 Configuration with a VE.Net panel

To this end, a VE.Net panel and the VE.Net to VE.Bus converter is required.

With VE.Net all parameters are accessible, with the exception of the multi-functional relay and the VirtualSwitch.

5.5 Configuration with DIP switches

A number of settings can be changed using DIP switches (see appendix A, position M).

This is done as follows:

Turn the MultiPlus on, preferably without load en without AC voltage on the input. The MultiPlus will then operate in inverter mode.

Step 1: Setting the DIP switches for:

- the required current limitation of the AC input.
- AES (Automatic Economy Switch)
- maximum charge current.
- selection of stand-alone, parallel or 3-phase operation.

To store the settings after the required values have been set: press the 'Up' button for 2 seconds (**upper** button to the right of the DIP switches, see appendix A, position J). The DIP switches can now be used to apply the remaining settings (step 2).

Step 2: other settings

To store the settings after the required values have been set: press the 'Down' button for 2 seconds (lower button to the right of the DIP switches). The DIP switches can be left in the selected positions, so that the 'other settings' can always be recovered.

Remarks:

- The DIP switch functions are described in 'top to bottom' order. Since the uppermost DIP switch has the highest number (8), descriptions start with the switch numbered 8.
- In parallel mode or 3-phase mode, not all devices require all settings to be made (see section 5.5.1.4).

For parallel or 3-phase mode, read the whole setting procedure and make a note of the required DIP switch settings before actually implementing them.

5.5.1 Step 1

5.5.1.1 Current limitation AC input (default: 50A)

If the current demand (MultiPlus load + battery charger) threatens to exceed the set AC input current, the MultiPlus will first reduce its charging current (PowerControl), and subsequently supply additional power from the battery (PowerAssist), if needed.

The AC input current limit can be set to eight different values by means of DIP switches.

With a Multi Control Panel, a variable current limit can be set for the AC input.

Remark: With a VE.bus Control Panel or a Digital Control Panel and an external AC change-over switch two different limits can be set, for two AC sources, for example the mains/grid and a generator.

Procedure

The AC input current limit can be set using DIP switches ds8, ds7 and ds6 (default setting: 50A).

Procedure: set the DIP switches to the required value:

ds8 ds7 ds6

off off off = 15A (1.8kVA at 120V)

off off on = 20A (2.4kVA at 120V)

off on off = 25A (3.0kVA at 120V)

off on on = 30A (3.6kVA at 120V)

on off off = 35A (4.2kVA at 120V)

on off on = 40A (4.8kVA at 120V)

on on off = 50A (6.0kVA at 120V)

on on on = not used

Remark: Manufacturer-specified continuous power ratings for small generators are sometimes inclined to be rather optimistic. In that case, the current limit should be set to a much lower value than would otherwise be required on the basis of manufacturer-specified data.

5.5.1.2 AES (Automatic Economy Switch)

Procedure: set ds5 to the required value:

ds5

off = AES off

on = AES on

5.5.1.3 Battery charge current limitation (default setting 75%)

For maximum battery life, a charge current of 10% to 20% of the capacity in Ah should be applied.

Example: optimal charge current of a 24V/500Ah battery bank: 50A to 100A.

The temperature sensor supplied automatically adjusts the charging voltage to the battery temperature.

If faster charging – and a subsequent higher current – is required:

- The temperature sensor supplied should always be fitted, since fast charging can lead to a considerable temperature rise of the battery bank. The charging voltage will be adapted to the higher temperature (i.e. lowered) by means of the temperature sensor.

- The bulk charge time will sometimes be so short that a fixed absorption time would be more satisfactory ('fixed' absorption time, see ds5, step 2).

Procedure

The battery charge current can be set in four steps, using DIP switches ds4 and ds3 (default setting: 75%).

ds4 ds3

off off = 25%

off on = 50%

on off = 75%

on on = 100%

5.5.1.4 Stand-alone, parallel, 3-phase and split phase operation

Using DIP switches ds2 and ds1, three system configurations can be selected.

NOTE:

- When configuring a parallel, 3-phase or split phase system, all related devices should be interconnected using RJ45 UTP cables (see appendix C, D). All devices must be turned on. They will subsequently return an error code (see Section 7), since they have been integrated into a system and still are configured as 'stand-alone'. This error message can safely be ignored.

- Storing settings (by pressing the 'Up' button (step 1) – and later on the 'Down' button (step 2) – for 2 seconds) should be done on one device only. This device is the 'master' in a parallel system or the 'leader' (L1) in a 3-phase or split phase system.

In a parallel system, the step-1 setting of DIP switches ds8 to ds3 need to be done on the master only. The slaves will follow the master with regard to these settings (hence the master/slave relationship).

In a 3-phase or split phase system, a number of settings are also required for the other devices, i.e. the followers (for phases L2 and L3).

(The followers, therefore, do not follow the leader for all settings, hence the leader/follower terminology).

- A change in the setting 'stand-alone / parallel / 3-phase' is only activated after the setting has been stored (by pressing the 'UP' button for 2 seconds) and after all devices have been turned off and then on again. In order to start up a VE.Bus system correctly, all devices should therefore be turned off after the settings have been stored. They can then be turned on in any order. The system will not start until all devices have been turned on.

- Note that only identical devices can be integrated in one system. Any attempt to use different models in one system will fail. Such devices may possibly function correctly again only after individual reconfiguration for 'stand-alone' operation.

The combination **ds2=on** and **ds1=on** is not used.

DIP switches ds2 and ds1 are reserved for the selection of stand-alone, parallel or 3-phase operation

Stand-alone operation

Step 1: Setting ds2 and ds1 for stand-alone operation

DS-8 AC input Set as desired
 DS-7 AC input Set as desired
 DS-6 AC input Set as desired
 DS-5 AES Set as desired
 DS-4 Charging current Set as desired
 DS-3 Charging current Set as desired
 DS-2 Stand-alone operation off
 DS-1 Stand-alone operation off

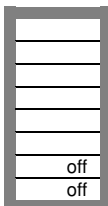

Examples of the other DIP switch settings for stand-alone mode are given below.

Example 1 shows the factory setting

Note: since factory settings are entered by computer, all DIP switches of a new product are set to 'off' and do not reflect the actual settings in the microprocessor.

Four examples of stand-alone settings:

DS-8 AC input <input type="checkbox"/> on DS-7 AC input <input type="checkbox"/> on DS-6 AC input <input type="checkbox"/> off DS-5 AES <input type="checkbox"/> off DS-4 Ch. current <input type="checkbox"/> on DS-3 Ch. current <input type="checkbox"/> off DS-2 St.-alone mode <input type="checkbox"/> off DS-1 St.-alone mode <input type="checkbox"/> off	DS-8 <input type="checkbox"/> on DS-7 <input type="checkbox"/> on DS-6 <input type="checkbox"/> off DS-5 <input type="checkbox"/> off DS-4 <input type="checkbox"/> on DS-3 <input type="checkbox"/> on DS-2 <input type="checkbox"/> off DS-1 <input type="checkbox"/> off	DS-8 <input type="checkbox"/> off DS-7 <input type="checkbox"/> on DS-6 <input type="checkbox"/> on DS-5 <input type="checkbox"/> off DS-4 <input type="checkbox"/> on DS-3 <input type="checkbox"/> on DS-2 <input type="checkbox"/> off DS-1 <input type="checkbox"/> off	DS-8 <input type="checkbox"/> on DS-7 <input type="checkbox"/> off DS-6 <input type="checkbox"/> on DS-5 <input type="checkbox"/> on DS-4 <input type="checkbox"/> off DS-3 <input type="checkbox"/> on DS-2 <input type="checkbox"/> off DS-1 <input type="checkbox"/> off
Step1, stand-alone Example 1 (factory setting): 8, 7, 6 AC-in: 50A 5 AES: off 4, 3 Charging current: 75% 2, 1 Stand-alone mode	Step1, stand-alone Example 2: 8, 7, 6 AC-in: 50A 5 AES: off 4, 3 Charge: 100% 2, 1 Stand-alone	Step1, stand-alone Example 3: 8, 7, 6 AC-in: 30A 5 AES: off 4, 3 Charge: 100% 2, 1 Stand-alone	Step1, stand-alone Example 4: 8, 7, 6 AC-in: 40A 5 AES: on 4, 3 Charge: 50% 2, 1 Stand-alone

To store the settings after the required values have been set: press the 'Up' button for 2 seconds (upper button to the right of the DIP switches, see appendix A, position J). The overload and low-battery LED's will flash to indicate acceptance of the settings.

We recommend making a note of the settings, and filing this information in a safe place.

You can now re-use the DIP switches to apply the remaining settings (step 2).

Parallel operation (appendix C)

Step 1: Setting ds2 and ds1 for parallel operation



Master		Slave 1	Slave 2 (optional)
DS-8 AC input	Set	DS-8 na	DS-8 na
DS-7 AC input	Set	DS-7 na	DS-7 na
DS-6 AC input	Set	DS-6 na	DS-6 na
DS-5 AES	na	DS-5 na	DS-5 na
DS-4 Ch. current	Set	DS-4 na	DS-4 na
DS-3 Ch. current	Set	DS-3 na	DS-3 na
DS-2 Master	off	DS-2 Slave 1	DS-2 Slave 2
DS-1 Master	on	DS-1 Slave 1	DS-1 Slave 2

The current settings (AC current limitation and charging current) are multiplied by the number of devices. However, the AC current limitation setting when using a remote panel will always correspond to the value indicated on the panel and is **not** multiplied by the number of devices.

Example: 9kVA parallel system

- If an AC input current limit of 20A is set on the master and the system consists of three devices, then the effective system current limit will be equal to $3 \times 20 = 60A$.
- If a 30A panel is connected to the master, the system current limit is adjustable to a maximum of 30A, regardless of the number of devices.
- If the charging current on the master is set to 100% (70A for a MultiPlus 24/3000/70) and the system consists of three devices, then the effective system charging current is equal to $3 \times 70 = 210A$.

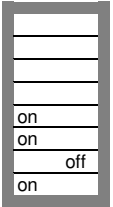
The settings according to this example (9kVA parallel system with 30A Multi Control Panel) are as follows:

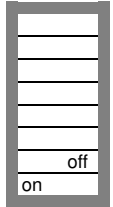
Master		Slave 1		Slave 2	
DS-8 na (30A panel)		DS-8 na		DS-8 na	
DS-7 na (30A panel)		DS-7 na		DS-7 na	
DS-6 na (30A panel)		DS-6 na		DS-6 na	
DS-5 AES na		DS-5 na		DS-5 na	
DS-4 Ch. current 3x70A		DS-4 na		DS-4 na	
DS-3 Ch. current 3x70A		DS-3 na		DS-3 na	
DS-2 Master		DS-2 Slave 1		DS-2 Slave 2	
DS-1 Master		DS-1 Slave 1		DS-1 Slave 2	
	on	off	off		
	on	off	on		

To store the settings after the required values have been set: press the 'Up' button of the **master** for 2 seconds (**upper** button to the right of the DIP switches, see appendix A, position J). **The overload and low-battery LED's will flash to indicate acceptance of the settings.**

We recommend making a note of the settings, and filing this information in a safe place. You can now re-use the DIP switches to apply the remaining settings (step 2).

Three phase operation (appendix D)

Step 1: Setting ds2 and ds1 for 3-phase operation

Leader (L1)		Follower (L2)		Follower (L3)	
DS-8 AC input	Set <input type="checkbox"/>	DS-8 Set	<input type="checkbox"/>	DS-8 Set	<input type="checkbox"/>
DS-7 AC input	Set <input type="checkbox"/>	DS-7 Set	<input type="checkbox"/>	DS-7 Set	<input type="checkbox"/>
DS-6 AC input	Set <input type="checkbox"/>	DS-6 Set	<input type="checkbox"/>	DS-6 Set	<input type="checkbox"/>
DS-5 AES	na <input type="checkbox"/>	DS-5 na	<input type="checkbox"/>	DS-5 na	<input type="checkbox"/>
DS-4 Ch. current	Set <input type="checkbox"/>	DS-4 na	<input type="checkbox"/>	DS-4 na	<input type="checkbox"/>
DS-3 Ch. current	Set <input type="checkbox"/>	DS-3 na	<input type="checkbox"/>	DS-3 na	<input type="checkbox"/>
DS-2 Leader	<input checked="" type="checkbox"/>	DS-2 Follower 1	<input type="checkbox"/>	DS-2 Follower 2	<input type="checkbox"/>
DS-1 Leader	<input type="checkbox"/>	DS-1 Follower 1	<input type="checkbox"/>	DS-1 Follower 2	<input checked="" type="checkbox"/>

As the table above shows, the AC-in current limits for each phase should be set separately (ds8 thru ds6). Different current limits per phase can be selected. If a panel is connected, the AC input current limit will equal the value set on the panel for all phases.

AES can be used on stand alone units only.

The maximum charge current is the same for all devices, and should be set on the leader only (ds4 and ds3).

Example:

- AC input current limit on the leader and the followers: 25A
- If the charge current on the leader is set to 100% (70A for a MultiPlus 24/3000/70) and the system consists of three devices, then the effective system charge current is equal to $- 3 \times 70 = 210A$.

The settings according to this example (9kVA 3-phase system without Multi Control Panel) are as follows:

Leader (L1)		Follower (L2)		Follower (L3)	
DS-8 AC input	25A <input type="checkbox"/>	DS-8 AC in 25A	<input type="checkbox"/>	DS-8 AC in 25A	<input type="checkbox"/>
DS-7 AC input	25A <input checked="" type="checkbox"/>	DS-7 AC in 25A	<input checked="" type="checkbox"/>	DS-7 AC in 25A	<input checked="" type="checkbox"/>
DS-6 AC input	25A <input type="checkbox"/>	DS-6 AC in 25A	<input type="checkbox"/>	DS-6 AC in 25A	<input type="checkbox"/>
DS-5 AES	na <input type="checkbox"/>	DS-5 na	<input type="checkbox"/>	DS-5 na	<input type="checkbox"/>
DS-4 Ch. current	3x70A <input checked="" type="checkbox"/>	DS-4 na	<input type="checkbox"/>	DS-4 na	<input type="checkbox"/>
DS-3 Ch. current	3x70A <input checked="" type="checkbox"/>	DS-3 na	<input type="checkbox"/>	DS-3 na	<input type="checkbox"/>
DS-2 Leader	<input checked="" type="checkbox"/>	DS-2 Follower 1	<input type="checkbox"/>	DS-2 Follower 2	<input type="checkbox"/>
DS-1 Leader	<input type="checkbox"/>	DS-1 Follower 1	<input type="checkbox"/>	DS-1 Follower 2	<input checked="" type="checkbox"/>

To store the settings after the required values have been set: press the 'Up' button of the leader for 2 seconds (upper button to the right of the DIP switches, see appendix A, position J). The overload and low-battery LED's will flash to indicate acceptance of the settings.

We recommend making a note of the settings, and filing this information in a safe place.

You can now re-use the DIP switches to apply the remaining settings (step 2).

Split phase operation (see figure 2a and 2b)

Step 1: Setting ds2 and ds1 for 2-phase (= split phase) operation

Leader (L1)		Follower (L2)	
DS-8 AC input	Set	DS-8 Set	
DS-7 AC input	Set	DS-7 Set	
DS-6 AC input	Set	DS-6 Set	
DS-5 AES	na	DS-5 na	
DS-4 Ch. current	Set	DS-4 na	
DS-3 Ch. current	Set	DS-3 na	
DS-2 Leader	on	DS-2 Follower 1	off
DS-1 Leader	off	DS-1 Follower 1	off

As the table above shows, the current limits for each phase should be set separately (ds8 thru ds5). Different current limits per phase can be selected.

If a panel is connected, the AC input current limit will equal the value set on the panel for all phases.

The maximum charging current is the same for all devices, and should be set on the leader (ds4 and ds3).

Example:

- AC input current limitation on the leader and the followers: 30A (setting for generator power $30 \times 120 \times 2 = 7\text{kVA}$).
- If the charging current on the leader is set to 100% (120A for a MultiPlus 24/5000/120) and the system consists of two devices, then the effective system charging current is equal to $2 \times 120 = 240\text{A}$.

The settings according to this example (15kVA 2-phase system) are as follows:

Leader (L1)		Follower (L2)	
DS-8 AC input	30A	DS-8 AC in	30A
DS-7 AC input	30A	DS-7 AC in	30A
DS-6 AC input	30A	DS-6 AC in	30A
DS-5 AES	na	DS-5 na	
DS-4 Ch. current	2x120A	DS-4 na	
DS-3 Ch. current	2x120A	DS-3 na	
DS-2 Leader	on	DS-2 Follower 1	off
DS-1 Leader	off	DS-1 Follower 1	off

To store the settings after the required values have been set: press the 'Up' button of the **leader** for 2 seconds (**upper** button to the right of the DIP switches, see appendix A, position K). **The overload and low-battery LED's will flash to indicate acceptance of the settings.**

We recommend making a note of the settings, and filling this information in a safe place. You can now re-use the DIP switches to apply the remaining settings (step 2).

5.5.2 Step 2: Other settings

Parallel operation: the remaining settings are not relevant (na) for slaves.

Three Phase or split phase: some of the remaining settings are not relevant for followers (L2, L3). These settings are imposed on the whole system by the leader L1. If a setting is irrelevant for L2, L3 devices, this is mentioned explicitly.

ds8-ds7: Setting charging voltages (not relevant for L2, L3)

ds8-ds7	Absorption voltage	Float voltage	Storage voltage	Suitable for
off off	14.1 28.2 56.4	13.8 27.6 55.2	13.2 26.4 52.8	Gel Victron Long Life (OPzV) Gel Exide A600 (OPzV) Gel MK battery
off on	14.4 28.8 57.6	13.8 27.6 55.2	13.2 26.4 52.8	Gel Victron Deep Discharge Gel Exide A200 AGM Victron Deep Discharge Stationary tubular plate (OPzS)
on off	14.7 29.4 58.8	13.8 27.6 55.2	13.2 26.4 52.8	AGM Victron Deep Discharge Tubular plate traction batteries in semi-float mode AGM spiral cell
on on	15.0 30.0 60.0	13.8 27.6 55.2	13.2 26.4 52.8	Tubular plate traction batteries in cyclic mode

ds6: absorption time 8 or 4 hours (na for L2, L3) on = 8 hours off = 4 hours

ds5: adaptive charging characteristic (na for L2, L3) on = active off = inactive
(inactive = fixed absorption time)

ds4: dynamic current limiter on = active off = inactive

ds3: UPS function on = active off = inactive

ds2: converter voltage on = 120V off = 115V

ds1: converter frequency (na for L2, L3) on = 50Hz off = 60Hz
(the wide input frequency range (45-55Hz) is 'on' by default)

Step 2: Exemplary settings for stand-alone mode

Example 1 is the factory setting.

Note: since factory settings are entered by computer, all DIP switches of a new product are set to 'off' and do not reflect the actual settings in the microprocessor.

DS-8 Ch. voltage <input type="checkbox"/> off DS-7 Ch. voltage <input type="checkbox"/> on DS-6 Absorpt. time <input type="checkbox"/> on DS-5 Adaptive ch. <input type="checkbox"/> on DS-4 Dyn. Curr. limit <input type="checkbox"/> off DS-3 UPS function: <input type="checkbox"/> on DS-2 Voltage <input type="checkbox"/> on DS-1 Frequency <input type="checkbox"/> off	DS-8 <input type="checkbox"/> off DS-7 <input type="checkbox"/> off DS-6 <input type="checkbox"/> on DS-5 <input type="checkbox"/> on DS-4 <input type="checkbox"/> off DS-3 <input type="checkbox"/> off DS-2 <input type="checkbox"/> on DS-1 <input type="checkbox"/> on	DS-8 <input type="checkbox"/> on DS-7 <input type="checkbox"/> off DS-6 <input type="checkbox"/> on DS-5 <input type="checkbox"/> on DS-4 <input type="checkbox"/> on DS-3 <input type="checkbox"/> off DS-2 <input type="checkbox"/> off DS-1 <input type="checkbox"/> on	DS-8 <input type="checkbox"/> on DS-7 <input type="checkbox"/> on DS-6 <input type="checkbox"/> off DS-5 <input type="checkbox"/> off DS-4 <input type="checkbox"/> off DS-3 <input type="checkbox"/> on DS-2 <input type="checkbox"/> off DS-1 <input type="checkbox"/> off
Step 2 Example 1 (factory setting): 8, 7 GEL 14,4V 6 Absorption time: 8 hours 5 Adaptive charging: on 4 Dynamic current limit: off 3 UPS function: on 2 Voltage: 120V 1 Frequency: 60Hz	Step 2 Example 2: 8, 7 OPzV 14,1V 6 Abs. time: 8 h 5 Adaptive ch.: on 4 Dyn. Curr. limit: off 3 UPS function: off 2 Voltage: 120V 1 Frequency: 50Hz	Step 2 Example 3: 8, 7 AGM 14,7V 6 Abs. time: 8 h 5 Adaptive ch.: on 4 Dyn. Curr. limit: on 3 UPS function: off 2 Voltage: 115V 1 Frequency: 50Hz	Step 2 Example 4: 8, 7 Tub.-plate 15V 6 Abs. time: 4 h 5 Fixed abs. time 4 Dyn. Curr. limit: off 3 UPS function: on 2 Voltage: 115V 1 Frequency: 60Hz

To store the settings after the required values have been set: press the 'Down' button for 2 seconds (lower button to the right of the DIP switches). **The temperature and low-battery LED's will flash to indicate acceptance of the settings.**

You can then leave the DIP switches in the selected positions, so that the 'other settings' can always be recovered.

Step 2: Exemplary setting for parallel mode

In this example, the master is configured according to factory settings.
The slaves do not require setting!

Master		Slave 1		Slave 2	
DS-8 Ch. voltage(GEL 14,4V)	<input type="checkbox"/> off	DS-8 na	<input type="checkbox"/>	DS-8 na	<input type="checkbox"/>
DS-7 Ch. voltage(GEL 14,4V)	<input checked="" type="checkbox"/> on	DS-7 na	<input type="checkbox"/>	DS-7 na	<input type="checkbox"/>
DS-6 Absorption time (8 h)	<input checked="" type="checkbox"/> on	DS-6 na	<input type="checkbox"/>	DS-6 na	<input type="checkbox"/>
DS-5 Adaptive charging (on)	<input checked="" type="checkbox"/> on	DS-5 na	<input type="checkbox"/>	DS-5 na	<input type="checkbox"/>
DS-4 Dyn. current limit (off)	<input type="checkbox"/> off	DS-4 na	<input type="checkbox"/>	DS-4 na	<input type="checkbox"/>
DS-3 UPS function (on)	<input checked="" type="checkbox"/> on	DS-3 na	<input type="checkbox"/>	DS-3 na	<input type="checkbox"/>
DS-2 Voltage (120V)	<input checked="" type="checkbox"/> on	DS-2 na	<input type="checkbox"/>	DS-2 na	<input type="checkbox"/>
DS-1 Frequency (60Hz)	<input type="checkbox"/> off	DS-1 na	<input type="checkbox"/>	DS-1 na	<input type="checkbox"/>

To store the settings after the required values have been set: press the 'Down' button of the **master** for 2 seconds (**lower** button to the right of the DIP switches). **The temperature and low-battery LED's will flash to indicate acceptance of the settings.**

You can then leave the DIP switches in the selected positions, so that the 'other settings' can always be recovered.

To start the system: first, turn all devices off. The system will start up as soon as all devices have been turned on.

Step 2: Exemplary setting for 3-phase mode

In this example the leader is configured according to factory settings.

Leader (L1)	Follower (L2)	Follower (L3)
DS-8 Ch. Volt. GEL 14,4V	DS-8 na	DS-8 na
DS-7 Ch. Volt. GEL 14,4V	DS-7 na	DS-7 na
DS-6 Absorption time (8 h)	DS-6 na	DS-6 na
DS-5 Adaptive ch. (on)	DS-5 na	DS-5 na
DS-4 Dyn. current limit (off)	DS-4 D. c. l. (off)	DS-4 D. c. l. (off)
DS-3 UPS function (on)	DS-3 UPS f. (on)	DS-3 UPS f. (on)
DS-2 Voltage (120V)	DS-2 V (120V)	DS-2 V (120V)
DS-1 Frequency (60Hz)	DS-1 na	DS-1 na

To store the settings after the required values have been set: press the 'Down' button of the **leader** for 2 seconds (**lower** button to the right of the DIP switches). **The temperature and low-battery LED's will flash to indicate acceptance of the settings.**

You can then leave the DIP switches in the selected positions, so that the 'other settings' can always be recovered.

To start the system: first, turn all devices off. The system will start up as soon as all devices have been turned on.

6. Maintenance

The MultiPlus does not require specific maintenance. It will suffice to check all connections once a year. Avoid moisture and oil/soot/vapours, and keep the device clean.

7. Error indications

With the procedures below, most errors can be quickly identified. If an error cannot be resolved, please refer to your Victron Energy supplier.

7.1 General error indications

Problem	Cause	Solution
No output voltage on AC-out-2.	MultiPlus in inverter mode Defective fuse F3 (see appendix A).	Remove overload or short circuit on AC-out-2 and replace fuse F3 (16A).
MultiPlus will not switch over to generator or mains operation.	Circuit breaker or fuse in the AC-in input is open as a result of overload.	Remove overload or short circuit on AC-out, and reset fuse/breaker.
Inverter operation not initiated when switched on.	The battery voltage is excessively high or too low. No voltage on DC connection.	Ensure that the battery voltage is within the correct range.
"Low battery" LED flashes.	The battery voltage is low.	Charge the battery or check the battery connections.
"Low battery" LED lights.	The converter switches off because the battery voltage is too low.	Charge the battery or check the battery connections.
"Overload" LED flashes.	The converter load is higher than the nominal load.	Reduce the load.
"Overload" LED lights.	The converter is switched off due to excessively high load.	Reduce the load.
"Temperature" LED flashes or lights.	The environmental temperature is high, or the load is too high.	Install the converter in cool and well-ventilated environment, or reduce the load.
"Low battery" and "overload" LEDs flash intermittently.	Low battery voltage and excessively high load.	Charge the batteries, disconnect or reduce the load, or install higher capacity batteries. Fit shorter and/or thicker battery cables.
"Low battery" and "overload" LEDs flash simultaneously.	Ripple voltage on the DC connection exceeds 1,5Vrms.	Check the battery cables and battery connections. Check whether battery capacity is sufficiently high, and increase this if necessary.
"Low battery" and "overload" LEDs light.	The inverter is switched off due to an excessively high ripple voltage on the input.	Install batteries with a larger capacity. Fit shorter and/or thicker battery cables, and reset the inverter (switch off, and then on again).

One alarm LED lights and the second flashes.	The inverter is switched off due to alarm activation by the lighted LED. The flashing LED indicates that the inverter was about to switch off due to the related alarm.	Check this table for appropriate measures in regard to this alarm state.
The charger does not operate.	The AC input voltage or frequency is not within the range set.	Ensure that the AC input is between 95 VAC and 140 VAC, and that the frequency is within the range set (default setting 45-65Hz).
	Circuit breaker or fuse in the AC-in input is open as a result of overload.	Remove overload or short circuit on AC-out, and reset fuse/breaker.
	The battery fuse has blown.	Replace the battery fuse.
	The distortion or the AC input voltage is too large (generally generator supply).	Turn the settings WeakAC and dynamic current limiter on.

The battery is not completely charged.	Charging current excessively high, causing premature absorption phase.	Set the charging current to a level between 0.1 and 0.2 times the battery capacity.
	Poor battery connection.	Check the battery connections.
	The absorption voltage has been set to an incorrect level (too low).	Set the absorption voltage to the correct level.
	The float voltage has been set to an incorrect level (too low).	Set the float voltage to the correct level.
	The available charging time is too short to fully charge the battery.	Select a longer charging time or higher charging current.
	The absorption time is too short. For adaptive charging this can be caused by an extremely high charging current with respect to battery capacity, so that bulk time is insufficient.	Reduce the charging current or select the 'fixed' charging characteristics.
The battery is overcharged.	The absorption voltage is set to an incorrect level (too high).	Set the absorption voltage to the correct level.
	The float voltage is set to an incorrect level (too high).	Set the float voltage to the correct level.
	Poor battery condition.	Replace the battery.
	The battery temperature is too high (due to poor ventilation, excessively high environmental temperature, or excessively high charging current).	Improve ventilation, install batteries in a cooler environment, reduce the charging current, and connect the temperature sensor.
The charging current drops to 0 as soon as the absorption phase initiates.	The battery is over-heated (>50 °C)	Install the battery in a cooler environment Reduce the charging current Check whether one of the battery cells has an internal short circuit
	Defective battery temperature sensor	Disconnect the temperature sensor plug in the MultiPlus. If charging functions correctly after approximately 1 minute, the temperature sensor should be replaced.

7.2 Special LED indications

(for the normal LED indications, see section 3.4)

Bulk and absorption LEDs flash synchronously (simultaneously).	Voltage sense error. The voltage measured at the voltage sense connection deviates too much (more than 7V) from the voltage on the positive and negative connection of the device. There is probably a connection error. The device will remain in normal operation. NOTE: If the "inverter on" LED flashes in phase opposition, this is a VE.Bus error code (see further on).
Absorption and float LEDs flash synchronously (simultaneously).	The battery temperature as measured has an extremely unlikely value. The sensor is probably defective or has been incorrectly connected. The device will remain in normal operation. NOTE: If the "inverter on" LED flashes in phase opposition, this is a VE.Bus error code (see further on).
"Mains on" flashes and there is no output voltage.	The device is in "charger only" operation and mains supply is present. The device rejects the mains supply or is still synchronising.

7.3 VE.Bus LED indications

Equipment included in a VE.Bus system (a parallel or 3-phase arrangement) can provide so-called VE.Bus LED indications. These LED indications can be subdivided into two groups: OK codes and error codes.

7.3.1 VE.Bus OK codes

If the internal status of a device is in order but the device cannot yet be started because one or more other devices in the system indicate an error status, the devices that are in order will indicate an OK code. This facilitates error tracing in a VE.Bus system, since devices not requiring attention are easily identified as such.

Important: OK codes will only be displayed if a device is not in inverter or charging operation!

- A flashing "bulk" LED indicates that the device can perform inverter operation.
- A flashing "float" LED indicates that the device can perform charging operation.

NOTE: In principle, all other LEDs must be off. If this is not the case, the code is not an OK code.

However, the following exceptions apply:

- The special LED indications above can occur together with the OK codes.
- The "low battery" LED can function together with the OK code that indicates that the device can charge.

7.3.2 VE.Bus error codes

A VE.Bus system can display various error codes. These codes are displayed with the "inverter on", "bulk", "absorption" and "float" LEDs.

To interpret a VE.Bus error code correctly, the following procedure should be followed:

1. Is the "inverter on" LED flashing? If not, then there is **no** VE.Bus error code.
2. If one or more of the LEDs "bulk", "absorption" or "float" flashes, then this flash must be in phase opposition to the "inverter on" LED, i.e. the flashing LEDs are off if the "inverter on" LED is on, and vice versa. If this is not the case, then there is **no** VE.Bus error code.
3. Check the "bulk" LED, and determine which of the three tables below should be used.
4. Select the correct column and row (depending on the "absorption" and "float" LEDs), and determine the error code.
5. Determine the meaning of the code in the tables below.

		Bulk LED off		
		Absorption LED		
		off	Flashing	on
Float LED	off	0	3	6
	flashing	1	4	7
	on	2	5	8

		Bulk LED flashes		
		Absorption LED		
		off	Flashing	on
Float LED	off	9	12	15
	flashing	10	13	16
	on	11	14	17

		Bulk LED on		
		Absorption LED		
		off	Flashing	on
Float LED	off	18	21	24
	flashing	19	22	25
	on	20	23	26

Code	Meaning:	Cause/solution:
1	Device is switched off because one of the other phases in the system has switched off.	Check the failing phase.
3	Not all, or more than, the expected devices were found in the system.	The system is not properly configured. Reconfigure the system. Communication cable error. Check the cables and switch all equipment off, and then on again.
4	No other device whatsoever detected.	Check the communication cables.
5	Overvoltage on AC-out.	Check the AC cables.
10	System time synchronisation problem occurred.	Should not occur in correctly installed equipment. Check the communication cables.
14	Device cannot transmit data.	Check the communication cables (there may be a short circuit).
16	System is switched off because it is a so-called extended system and a 'dongle' is not connected.	Connect dongle.
17	One of the devices has assumed 'master' status because the original master failed.	Check the failing unit. Check the communication cables.
18	Overvoltage has occurred.	Check AC cables.
22	This device cannot function as 'slave'.	This device is an obsolete and unsuitable model. It should be replaced.
24	Switch-over system protection initiated.	Should not occur in correctly installed equipment. Switch all equipment off, and then on again. If the problem recurs, check the installation.
25	Firmware incompatibility. The firmware of one the connected devices is not sufficiently up to date to operate in conjunction with this device.	1) Switch all equipment off. 2) Switch the device returning this error message on. 3) Switch on all other devices one by one until the error message reoccurs. 4) Update the firmware in the last device that was switched on.
26	Internal error.	Should not occur. Switch all equipment off, and then on again. Contact Victron Energy if the problem persists.

8. Technical specifications

MultiPlus	12 Volt 24 Volt	12/3000/120 – 50 120V 24/3000/70 – 50 120V
PowerControl / PowerAssist		yes
Transfer switch		50A
Minimum PowerAssist current		11A
INVERTER		
Input voltage range		9,5 – 17 V 19 – 33 V
Output (1)		Output voltage: 120 VAC ± 2% Frequency: 60 Hz ± 0,1%
Cont. output power at 75 °F (VA) (3)		3000
Cont. output power at 75 °F (W)		2500
Cont. output power at 100 °F (W)		2000
Peak power (W)		6000
Maximum efficiency (%)		93 / 94
Zero-load power (W)		15 / 15
		10 / 10
		4 / 5
CHARGER		
AC Input		Input voltage range: 95-140 VAC Input frequency: 45 – 65 Hz Power factor: 1
Charge voltage 'absorption' (V DC)		14,4 / 28,8
Charge voltage 'float' (V DC)		13,8 / 27,6
Storage mode (V DC)		13,2 / 26,4
Charge current house battery (A) (4)		120 / 70
Charge current starter battery (A)		4
Battery temperature sensor		yes
GENERAL		
Programmable relay (5)		yes
Protection (2)		a - g
Common Characteristics		Operating temp. range: 0 - 120 °F (fan assisted cooling) Humidity (non condensing) : max 95%
ENCLOSURE		
Common Characteristics		Material & Colour: aluminum (blue RAL 5012) Protection category: IP 21
Battery-connection		M8 bolts (2 plus and 2 minus connections)
120 V AC-connection		screw-terminals 6 AWG (13mm ²)
Weight		19kg 42 lbs
Dimensions		362 x 258 x 218 mm 14.3 x 10.2 x 8.6 inch
STANDARDS		
Safety		EN 60335-1, EN 60335-2-29
Emission / Immunity		EN55014-1, EN 55014-2, EN 61000-3-3

- 1) Can be adjusted to 50Hz
- 2) Protection
 - a. Output short circuit
 - b. Overload
 - c. Battery voltage too high
 - d. Battery voltage too low
 - e. Temperature too high
 - f. 120VAC on inverter output
 - g. Input voltage ripple too high
- 3) Non linear load, crest factor 3:1
- 4) At 25 °C ambient
- 5) Programmable relay which can be set for general alarm, DC undervoltage or genset start signal function

APPENDIX A Overview connections

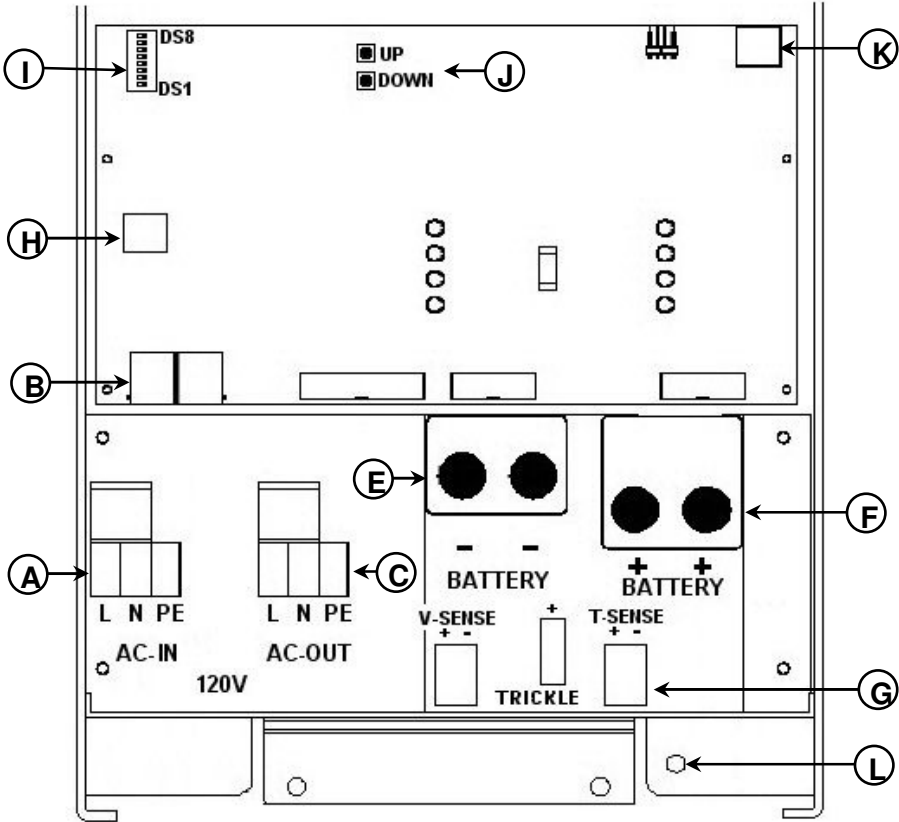

A	AC input: (left to right) L (phase), N (neutral), PE (ground).
B	2x RJ45 connector for remote control and/or parallel / three-phase operation
C	AC output: (left to right)) L (phase), N (neutral), PE (ground).
E	Battery minus.
F	Battery plus.
G	Terminals for: (left to right) Voltage sense plus, Voltage sense minus, Starter battery plus, Temperature sensor plus, Temperature sensor minus.
H	Connections for remote switch: Short left and middle terminal to switch the MultiPlus "on", Short right and middle terminal to switch the MultiPlus to "charger only".
I	Dipswitches DS1 tm DS8 for set-up mode.
J	Pushbuttons for set-up mode.
K	Alarm contact: (left to right) NC, NO, COM
L	Primary ground connection (PE)

APPENDIX B: Block diagram

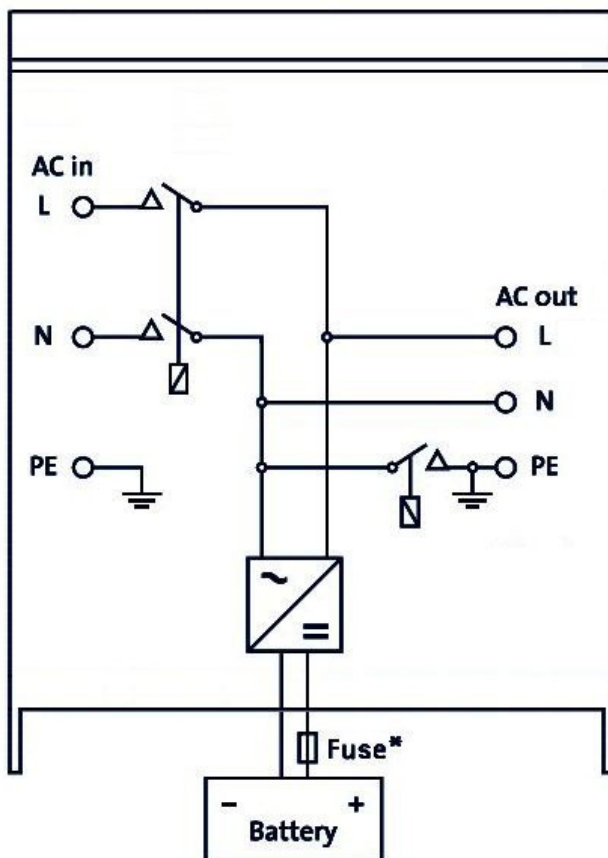

* See table in section 4.2

APPENDIX C: Parallel connection

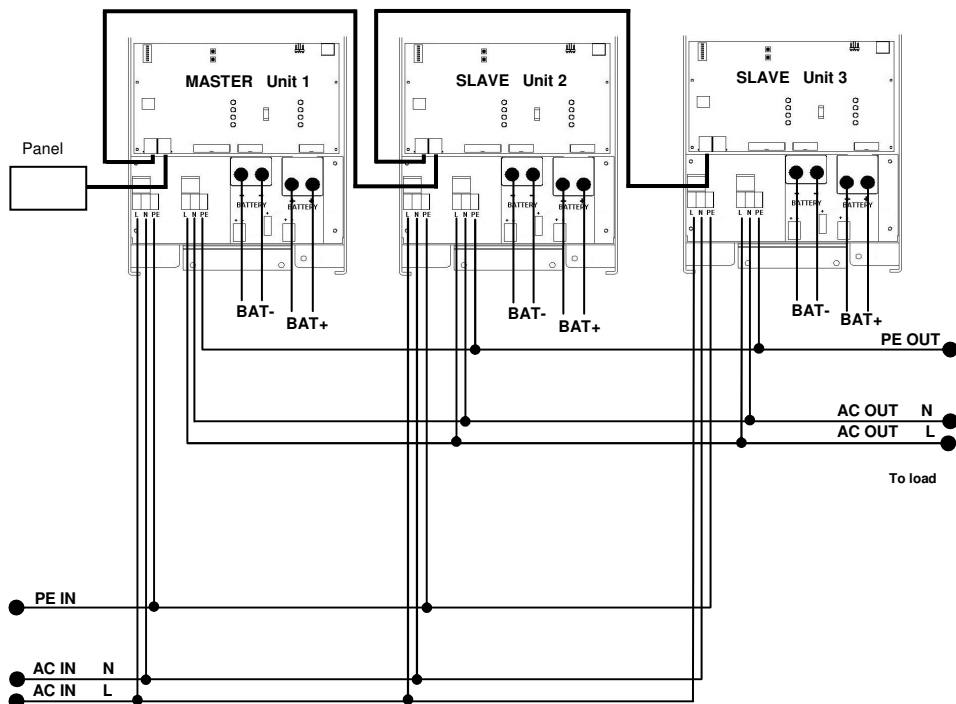

APPENDIX D: Three phase connection

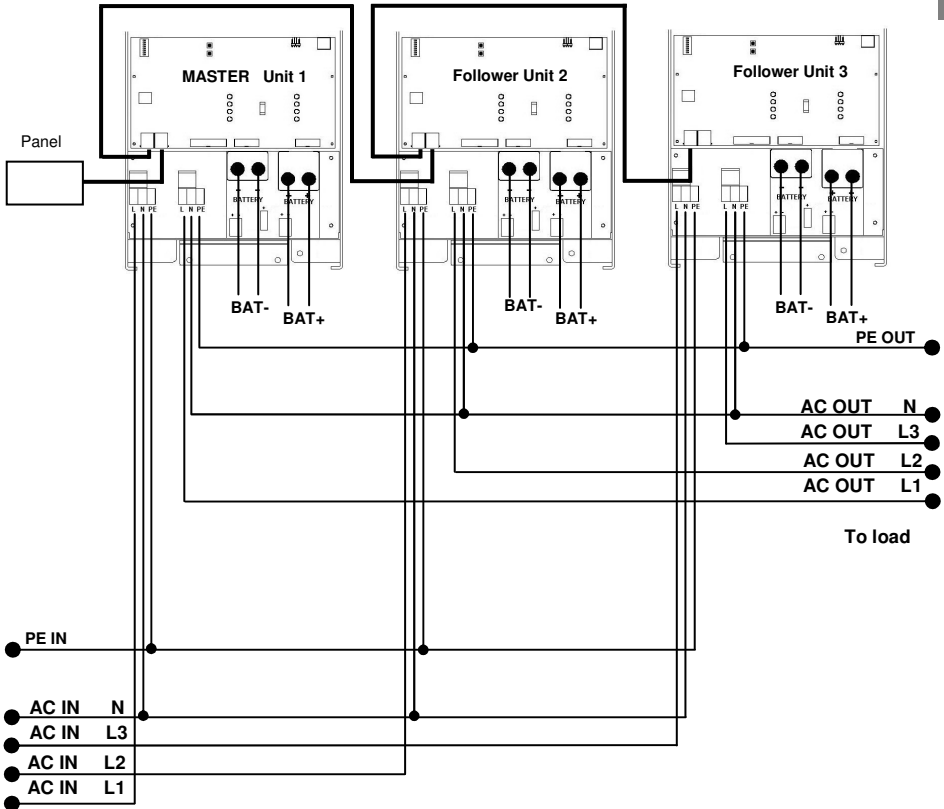

APPENDIX E: Charge characteristic

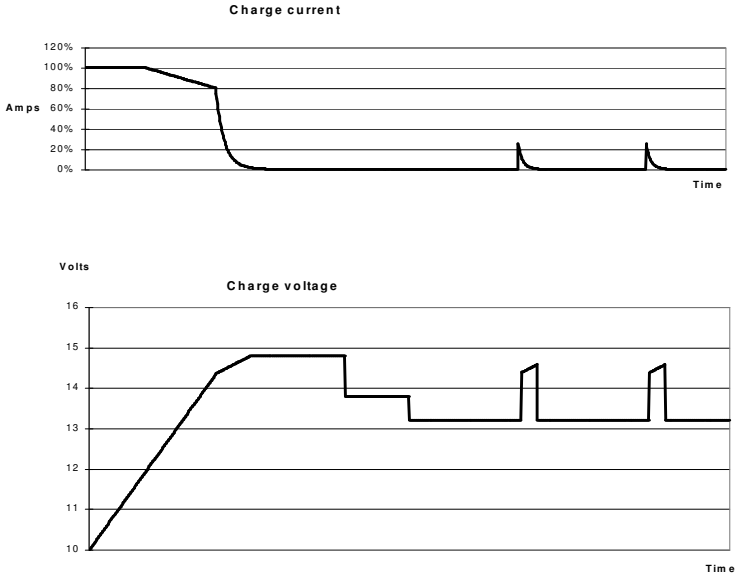

4-stage charging:

Bulk

Entered when charger is started. Constant current is applied until nominal battery voltage is reached, depending on temperature and input voltage, after which constant power is applied up to the point where excessive gassing is starting (14.4V resp. 28.8V, temperature compensated).

Battery Safe

The applied voltage to the battery is raised gradually until the set Absorption voltage is reached. The Battery Safe Mode is part of the calculated absorption time.

Absorption

The absorption period is dependent on the bulk period. The maximum absorption time is the set Maximum Absorption time.

Float

Float voltage is applied to keep the battery fully charged

Storage

After one day of float charge the output voltage is reduced to storage level. This is 13,2V resp. 26,4V (for 12V and 24V charger). This will limit water loss to a minimum when the battery is stored for the winter season.

After an adjustable time (default = 7 days) the charger will enter Repeated Absorption-mode for an adjustable time (default = one hour) to 'refresh' the battery.

APPENDIX F: Temperature compensation

EN

Appendix

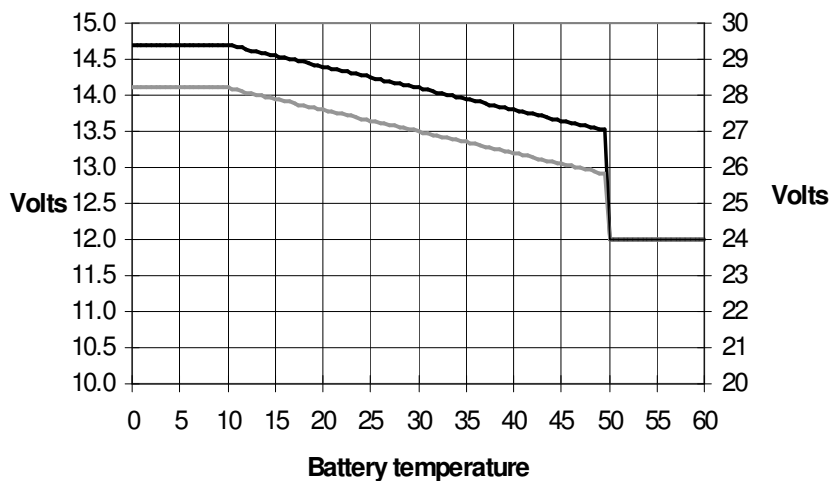

Default output voltages for Float and Absorption are at 25°C.
Reduced Float voltage follows Float voltage and Raised Absorption voltage follows Absorption voltage.
In adjust mode temperature compensation does not apply.

APPENDIX G: Dimensions

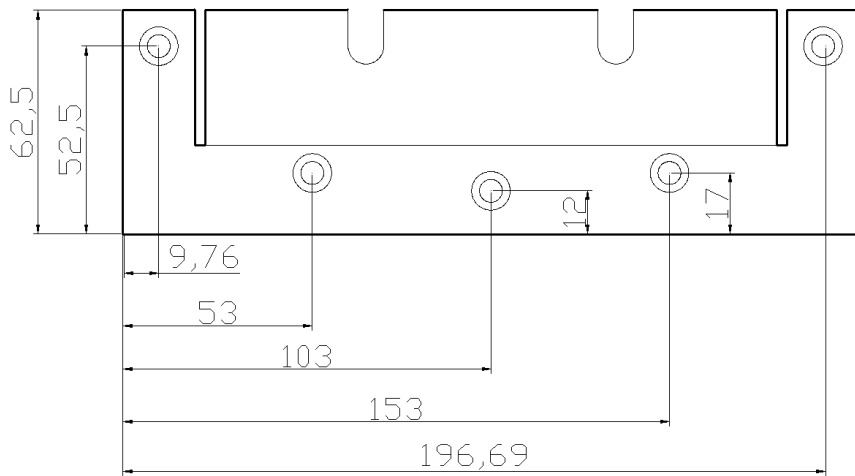

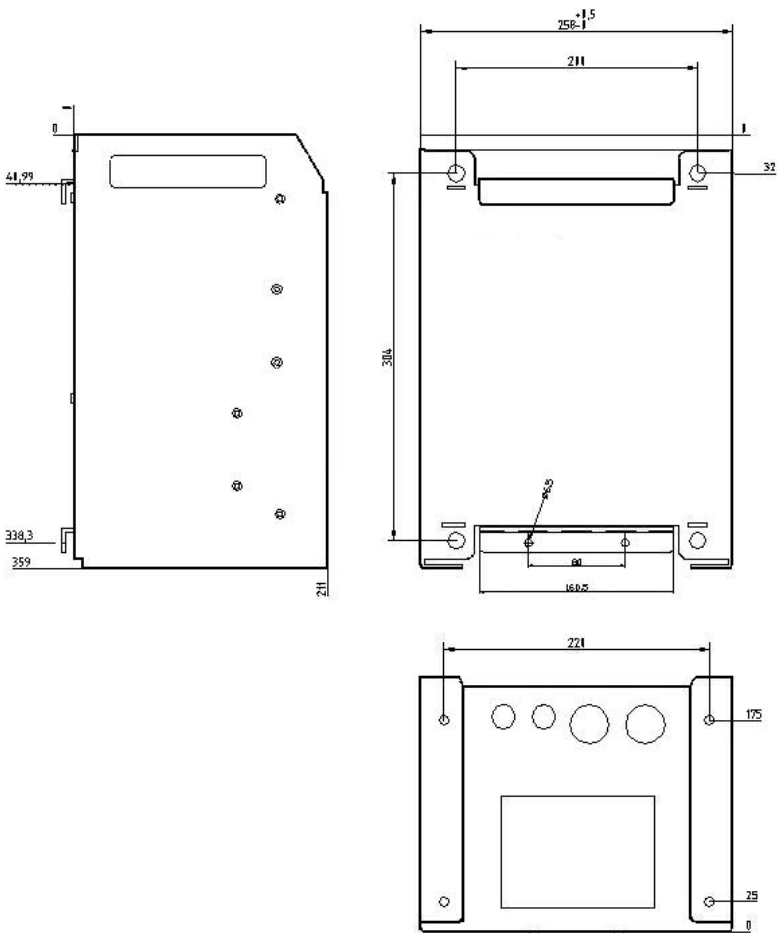

Victron Energy Blue Power

Distributor:

Serial number:

Version : 00

Date : 11 February 2009

Victron Energy B.V.

De Paal 35 | 1351 JG Almere

PO Box 50016 | 1305 AA Almere | The Netherlands

General phone : +31 (0)36 535 97 00

Customer support desk : +31 (0)36 535 97 03

Fax : +31 (0)36 535 97 40

E-mail : sales@victronenergy.com

www.victronenergy.com